



# WP1: Electromachinery Final Report

*ABB Corporate Research Center, Kraków, Poland  
Politechnika Krakowska, Kraków, Poland*

31/03/2015

# WP1 Objectives

- Modelling of electromechanical system with effects of interactions for diagnostic purpose
- Undertake data capture, conditioning and analysis with advance signal processing methods for diagnosis of electrical/mechanical interactions
- Create diagnostic algorithms based on intelligent calculation (neural network, fuzzy logic, pattern recognition) for machines assessment in industry electric drives.
- Develop a systematic framework for increasing diagnostic reliability through combination of global diagnostic signals or diagnostic indicators





# WP 1: Technical Details

## ESR-A (Alejandro Fernandez Gomez)



### *Modelling of electromechanical system with effects of electrical/mechanical interactions for diagnostic purposes*

- Modelling of failure modes in induction motors
  - Eccentricities and Broken Bars
  - Focus on how faults break symmetry in the motor
  - Theoretical results are verified through experiments involving laboratory motors
  - Models planned to be applicable for diagnostics purposes AND control approaches.
  - Discretization of model and implementation into ZYNQ system (ARM+FPGA)
  - Hardware in the Loop – understand the interaction between motor and drive.
- **Secondment: ETH Zurich: Aug- Oct 2013 / April-May 2014**
- ABB PLCRC: Oct 2013 – Jan 2014**

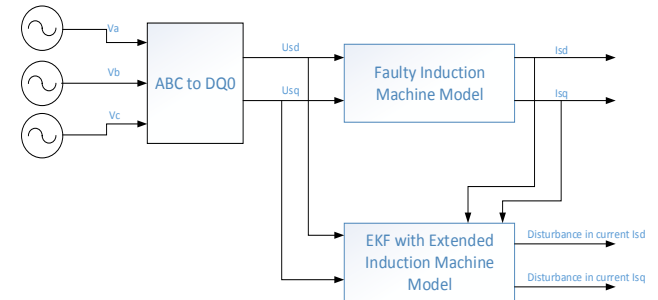



## WP 1: Technical Details ESR-B (José Gregorio Ferreira De Sá)



- *Data capturing, conditioning and analysis with advanced signal processing methods determination of feature relationships for diagnosis of electrical/mechanical interactions.*
- *Diagnostic algorithm creation for assessment of machinery with industrial electric drives*

- Research on the detection of damage of stators and rotors in synchronous machines for high-power systems.
- Extensive development of a laboratory test rig incl. a scaled model of a motor that allows for the introduction of various failure modes into the system.
- Practical expertise on advance signal processing techniques, machine learning and development of data driven models.
- Able to record a number of signals typically unavailable (e.g. rotor signals)

- Work on understanding drives used in industry e.g. LCIs
  - Design and construction of PWM-controlled DC source.
- Design and production of PCB and the required embedded software

- **Secondment: ABB Norway: April-July, 2014**  
**ABB PLCRC\*: Regular Interaction**

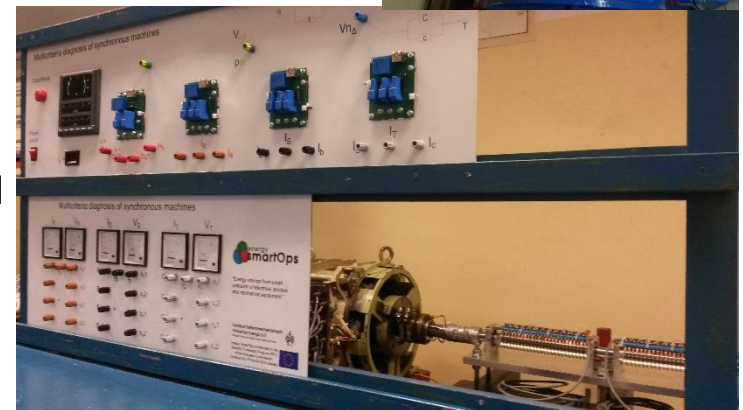
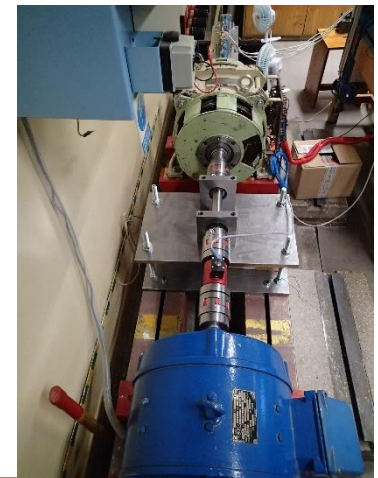



# WP 1: Technical Details

## ESR-C (Victor-Hugo Jaramillo-Velasquez)



*Identify and use global indicators that could point to problems with multiple subsystems*

- Studied typical diagnostics approaches:
    - Vibration**                      **Motor Current**                      **Oil Debris**
    - Drive Signals**                      **Temperatures**                      **Process data**
  - Considerable research into Data Fusion  
Focus areas: **Neural Networks**, **Bayesian Inference** and **Kalman Filter**
  - Developed a novel technique for the Data Fusion of different condition monitoring indicators.
  - This approach has been filed for protection with the intention that it will properly realized in practice
  - Data Fusion of Signals
    - Oil Debris analysis + Vibration analysis
- Secondment: ETH Zurich, Institute for Automatic Control (IFA) May 2014.**
- MPC techniques for Motors and their Load
  - Study of Minimum Loses Control for Internal Permanent Magnet Motors.

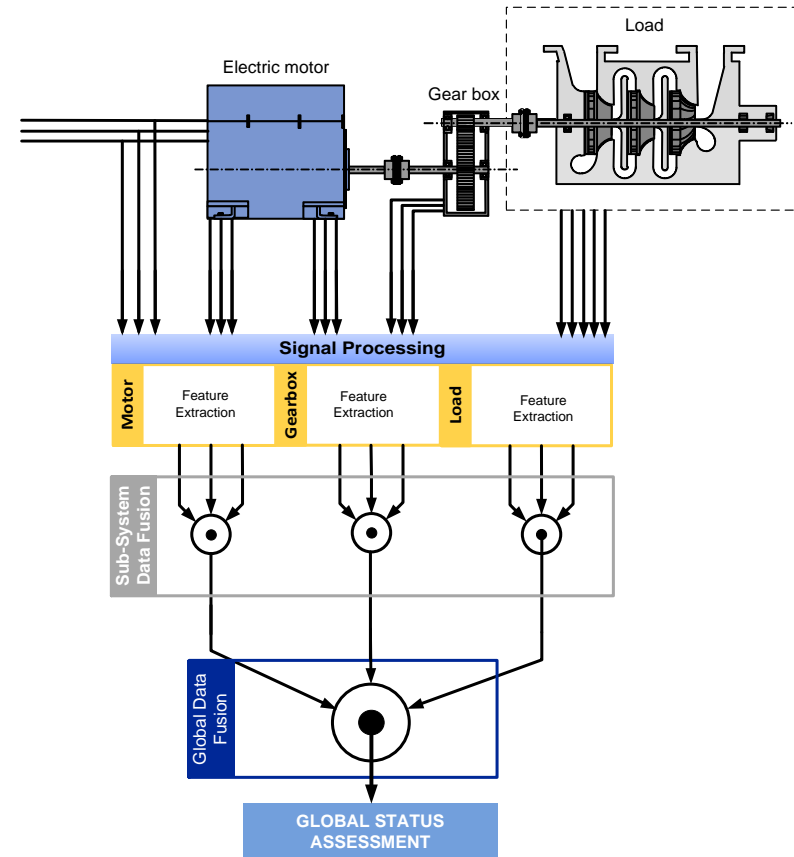

## Networking: Site Visits and Collaborations (outside of WP Participants)



- Site visit to the ABB Motor and Drive factories in Łódź, Poland

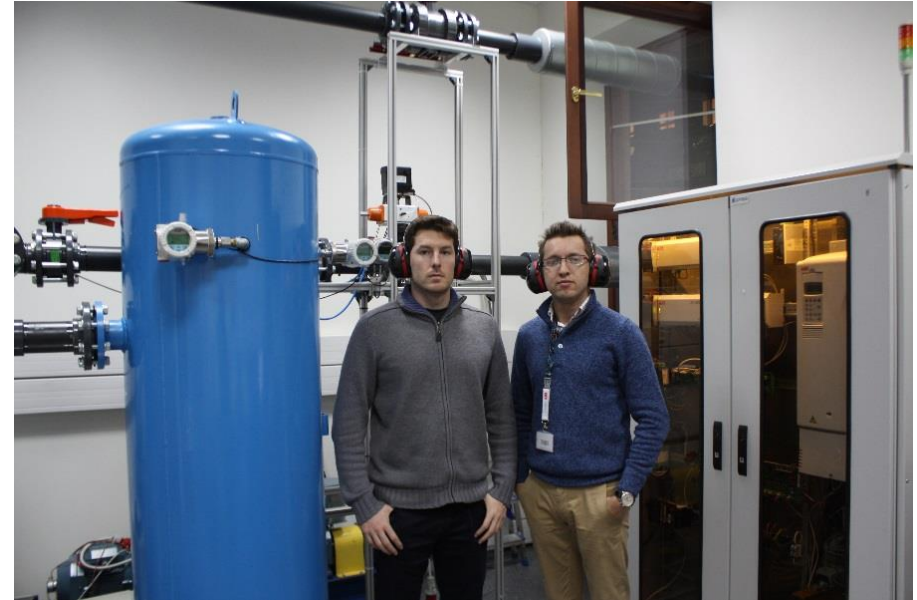

- ESR-D participated in an additional secondment (Nov-Dec 2013) at ABB Corporate Research Center Kraków, to perform a series of experiments on a Compressor Rig.
- ESR-O visited ABB Corporate Research Center Kraków to work on control of state-of-the-art compressors.

## Dissemination and Training: Publications, Conferences, Workshops



- Workshop on advanced diagnostic of electromechanical system, 15<sup>th</sup> -16<sup>th</sup> November 2012
- Summer School on Modeling of Interaction in Electro-Mechanical Systems, 26<sup>th</sup> -27<sup>th</sup> May 2014
- ESR-C conducted workshops on “*Smart Energy for a Better World.*” These activities are carried out with students of the EESTEC network in cooperation with the AGH University in Krakow, Poland.
- All ESRs have participated in a wide range of training activities
  - Local, External and Online
  - Both Soft Skills and Technical Development

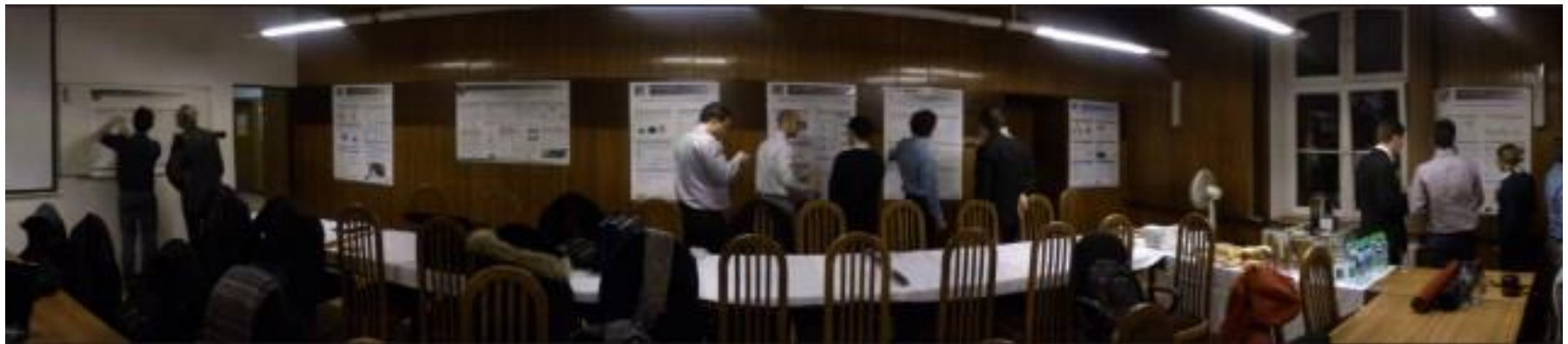

## A. Alejandro Fernandez Gomez

- Alejandro Fernández Gómez and Tadeusz J. Sobczyk, 2013, Influence of induction motor design data on effects of cage asymmetry, *Journal of Energy and Power*, 7, 1586-1591.
- Alejandro Fernandez Gomez and Tadeusz J. Sobczyk, 2013, Motor current signature analysis apply for external mechanical fault and cage asymmetry in induction motors *9th IEEE International Symposium on Diagnostics for Electric Machines, Power Electronics and Drives (SDEMPED)*, 27-30 Aug. 2013, Valencia.
- Alejandro Fernandez Gomez, Victor H. Jaramillo, and James R. Ottewill, 2014, Fault detection in electric motors by means of the extended Kalman filter as disturbance estimator, *UKACC 10th International Conference on Control*, Loughborough University, 9-11 July 2014.

## B. José Gregorio Ferreira De Sá

- José Gregorio Ferreira, Tadeusz J. Sobczyk, Adam Warzecha, 2014, Multicriteria diagnosis of synchronous machine using MCSA, *Zeszyty Problemowe – Maszyny Elektryczne* 4, 293-299
- José Gregorio Ferreira and Tadeusz J. Sobczyk, 2014, Multicriteria diagnosis of synchronous machines: rotor-mounted sensing system, *UKACC 10th International Conference on Control*, Loughborough University, 9-11 July 2014.

## C. Victor-Hugo Jaramillo-Velasquez

- Ruiz-Cárcel, V.H. Jaramillo, D. Mba, J.R. Ottewill and Y. Cao, Improved Condition Monitoring using Fast-Oscillating Measurements, *The 20th International Conference on Automation and Computing (ICAC'14)* Cranfield University, Bedfordshire, UK, 12-13 September 2014.
- G. Torrisi, S. Mariethoz, R.S. Smith, M. Morari, J.R. Ottewill and V.H. Jaramillo-Velasquez, Active Surge Control of Electrically Driven Centrifugal Compressors, *ECC '15, The European Control Conference* Linz, Austria, July 15-17 2015.



## A. Alejandro Fernandez Gomez

- Soft Skills – Polish Language Level A1 / FEC Level B2 / Introduction to Business: Strategy
- University courses (Politechnika Krakowska) - Advanced Modelling of Electromechanical Systems
- External Technical Courses: Matlab Training – Signal Processing with Simulink / Building Interactive Applications in Matlab; Labview Core 1 & Core 2

## B. José Gregorio Ferreira De Sá

- Soft Skills – Polish Language Level A1 / Energy SmartOps Professional Skills Course
- University courses (Politechnika Krakowska) - Advanced Modelling of Electromechanical Systems
- External courses: Modelling of electric drives systems; Cranfield University / Machine Learning Summer school, TU Dortmund University / Different Matlab courses / Labview Core 1 & Core 2.
- Online Courses: e.g. Data Scientist specialization, Machine Learning and others from Coursera.

## C. Victor-Hugo Jaramillo-Velasquez

- Soft Skills including Polish Language Course and R&D Project Management
- University courses (Politechnika Krakowska) - Advanced Modelling of Electromechanical Systems
- (Certified as Vibration Analyst to Cat. II level by Mobius Institute)
- Online Courses (e.g. Coursera)

# Impact: Energy Usage Without Condition Monitoring

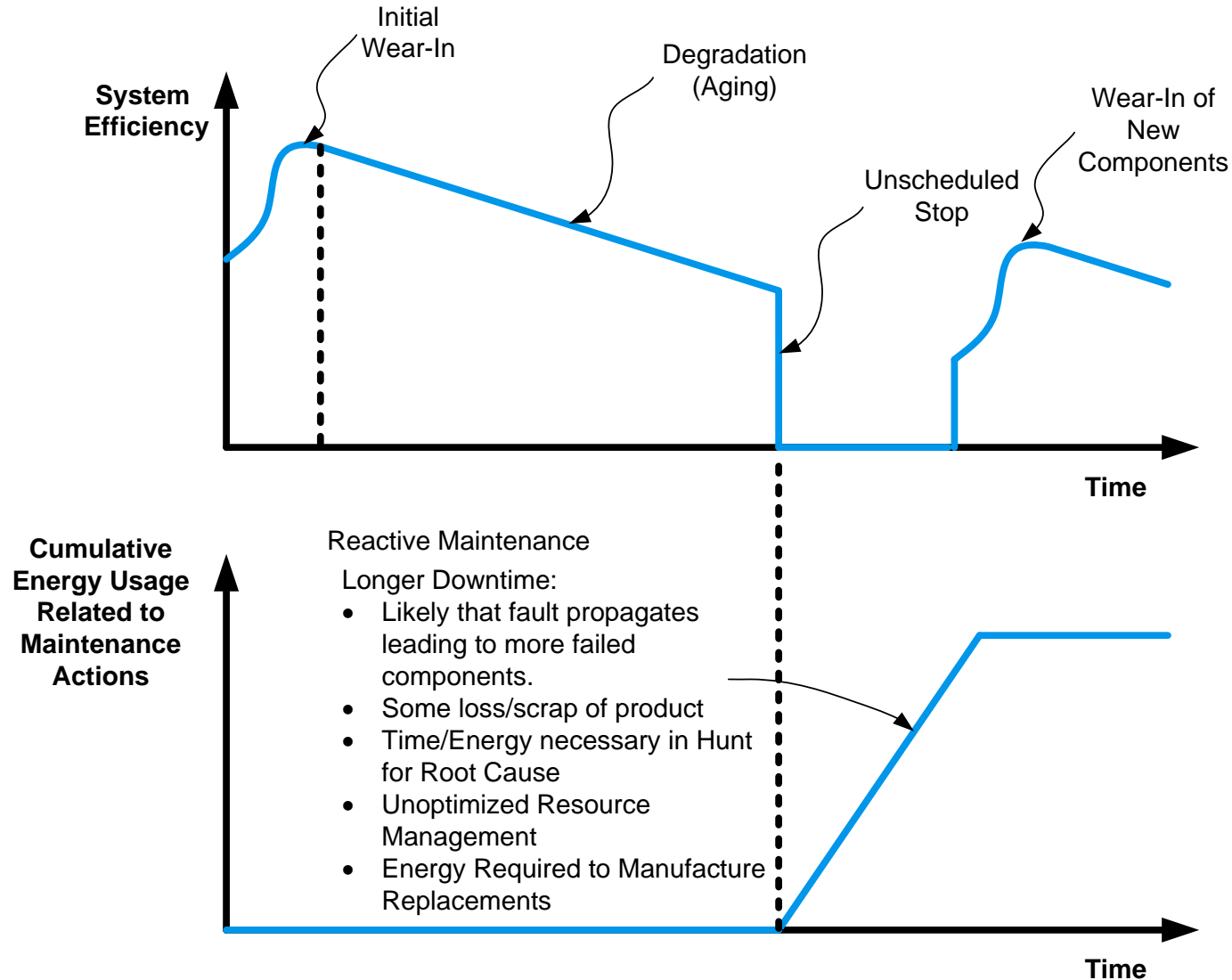

# Impact: Energy Usage With Condition-Based Maintenance

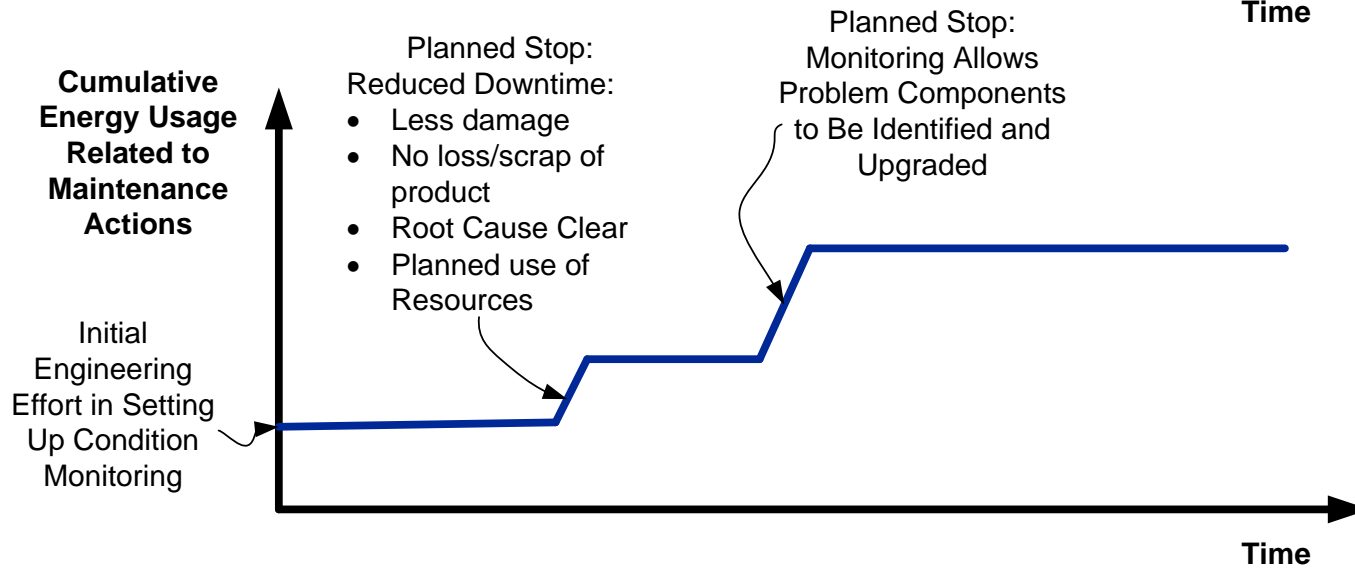
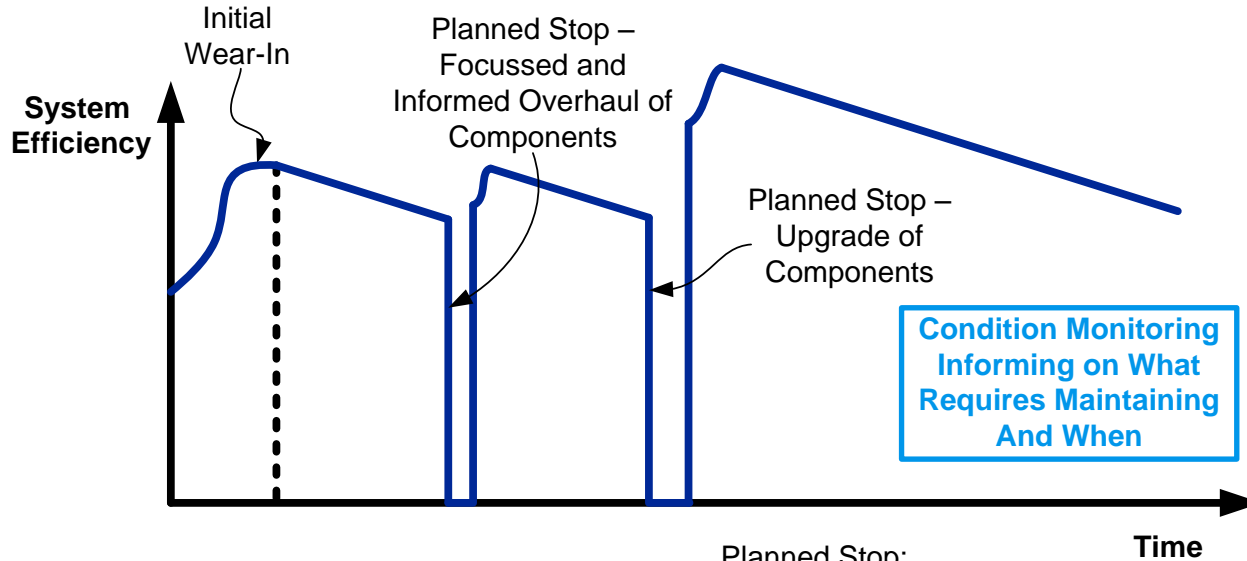

# WP 1: Electromachinery

## WP Objectives - Status



### INTENDED OUTCOME

Increasingly, electrical motors are at the heart of a wide variety of industrial processes.

Induction machines are the workhorse of industrial processes. It is necessary to understand and exploit their dynamics in order to successfully diagnose their health.

Synchronous machines are typically used to drive critical processes. It was intended to identify new techniques for monitoring such machines.

Electrical machines form part of a larger system of interacting components. This workpackage also aimed to utilize these interactions to achieve more comprehensive condition monitoring.

Increasing confidence levels in condition monitoring techniques makes condition-based maintenance more feasible. Such maintenance strategies can result in reduced energy losses through maintenance actions.

### METHODOLOGY DEVELOPED

Preparation of models of induction machines in both healthy and faulty states. Models have been validated using specially-prepared experimental test stands.

Design, implementation and testing of advanced measurement system for synchronous machines, including non-standard sensing equipment. Collection of a large database of signals recorded from the machine under various health states. This allows new advanced diagnostics algorithms to be developed.

Development of a multi-sensor data fusion approach for combining diagnostics signals and events from multiple sources. Approaches based on Artificial Neural Networks and Bayesian Networks have been created and validated using real data.

### MEASURE OF SUCCESS

New diagnostic algorithms allow electrical faults to be distinguished from mechanical faults. This reduces the likelihood of misdiagnosis, leading to more confidence in monitoring results. Energy that would have otherwise been used to investigate misdiagnoses is thus saved.

The health of synchronous machines is relatively difficult to diagnose using standard methods. New measurement approaches and algorithms have been developed which allow synchronous machine faults to be identified. This reduces the need for inefficient periodic maintenance stops to the process.

Bayesian Network approach for combining condition monitoring results from multiple subsystems, allows the most-likely source of a fault to be identified, resulting in reduced downtime and more accurate diagnosis. Hence less energy is expended solving maintenance issues.