

Imperial Moratuwa Mk2 External Fixator Comparative Mechanical Tests

Author: Spencer Barnes

Date: 17th of May 2019

Tests were performed on the 17th of April, the 3rd of May and the 17th of May 2019 in the Biomechanics Laboratory, Department of Mechanical Engineering, Imperial College London.

Issue 1

Version 4

IMPERIAL COLLEGE

Contents

Disclaimer 3

List of Figures..... 4

List of Tables..... 5

Introduction..... 6

Engineering Drawings..... 7

 Large Clamp 7

 Small Clamp 8

 Assembly..... 9

General Methods..... 10

Individual Clamp Compressive Axial Test 11

 Methods 11

 Large Clamp 11

 Small Clamp 13

 Results 15

 Large Clamp 15

 Small Clamp 17

Clamp Interface Tests 19

 Methods 19

 Results 21

System Tests 23

 Methods 23

 Results 25

Preliminary Discussion..... 26

 Limitations..... 26

 Other Observations 26

Appendices..... 27

 Appendix A – Mechanical Testing Machine Calibration Certificate 27

 Appendix B – Torque Wrench Calibration Certificate 32

 Appendix C – Testing Orders 33

 Appendix D – Vernier Calliper Calibration..... 35

Disclaimer

The information contained in this document is confidential and is **ONLY** for the intended recipients. This report details the design and mechanical testing of a device in development and includes some preliminary discussion of results - this is privileged information at this time.

The contents of this document are **NOT** to be published, disseminated or distributed in any form without the prior permission of all investigators.

IMPERIAL COLLEGE

List of Figures

Figure 1 - Moratuwa (top) & Imperial (bottom) manufactured large and small clamps.	6
Figure 2 - Large clamp drawing.	7
Figure 3- Large clamp quality control document.	7
Figure 4 - Small clamp drawing.	8
Figure 5 - Small clamp quality control document.....	8
Figure 6 - Mk2 External Fixator assembly drawing.	9
Figure 7 - Axial compression test of an Imperial manufactured large clamp.	11
Figure 8 - Imperial large clamp no 3 final compression test.	12
Figure 9 - Moratuwa large clamp no 3 final compression test.....	12
Figure 10 - Axial compression test of a Moratuwa manufactured small clamp.....	13
Figure 11 - Imperial small clamp no 2 final compression test.....	14
Figure 12 - Moratuwa small clamp no 2 final compression test.....	14
Figure 13 – All large clamp load corrected extension graphs.	15
Figure 14 – All large clamp linear region load corrected extension graphs.....	15
Figure 15 - Large clamp axial compression test bar chart. ± 1 standard deviation error bars.....	16
Figure 16 - Large clamp slit distance bar chart. ± 1 standard deviation error bars.....	16
Figure 17 – All small clamp load corrected extension graphs.....	17
Figure 18 – All small clamp linear region load corrected extension graphs.....	17
Figure 19 - Small clamp axial compression test bar chart. ± 1 standard deviation error bars.....	18
Figure 20 - Small clamp slit distance bar chart. ± 1 standard deviation error bars.....	18
Figure 21 - Interface mechanical test set up. Imperial Mk2 side view (top left), Moratuwa Mk2 isometric view (top right) & CAD drawing (bottom).....	19
Figure 22 - Imperial interface test no1 (small clamp no4 & large clamp no1) final test.....	20
Figure 23 - Moratuwa interface test no4 (small clamp no2 & large clamp no2) final test.....	20
Figure 24 - All clamp interface load corrected extension graphs.....	21
Figure 25 - All linear region clamp interface load corrected extension graphs.....	21
Figure 26 - Clamp interface test result bar chart. ± 1 standard deviation error bars.....	22
Figure 27 - System mechanical test set up. Moratuwa Mk2 front view (left), Imperial Mk2 isometric view (middle) & CAD drawing (right).....	23
Figure 28 - Imperial system test no1 final test.....	24
Figure 29 - Moratuwa system test no4 final test.....	24
Figure 30 - Stryker system test no2 final test.....	24
Figure 31 - All system test load corrected extension graphs.....	25
Figure 32- System stiffness test results bar chart. ± 1 standard deviation error bars.....	25

List of Tables

Table 1 - Large clamp compressive axial mechanical test results. 16

Table 2 - Small clamp compressive axial mechanical test results. 18

Table 3 - Clamp interface mechanical test results. 22

Table 4 - System mechanical test results. 25

Table 5 - Individual clamp testing orders 33

Table 6 - Clamp interface testing orders and randomised clamp combinations. 33

Table 7 - System testing orders and randomised clamp combinations. Figure 27 details clamp combination locations. 34

Table 8 - Vernier calliper calibration against slip gauges used by the Research & Development Workshop, Department of Mechanical Engineering, Imperial College London for machine calibration. Slip gauges were measured with the lower/outside measuring jaws of the Vernier calliper. Pass criteria was determined by the measurement being ± 0.03 mm of the slip gauge value, this is the stated accuracy of the Vernier calliper. Calibration was performed by the author on the 17th of April 2019 at room temperature. 35

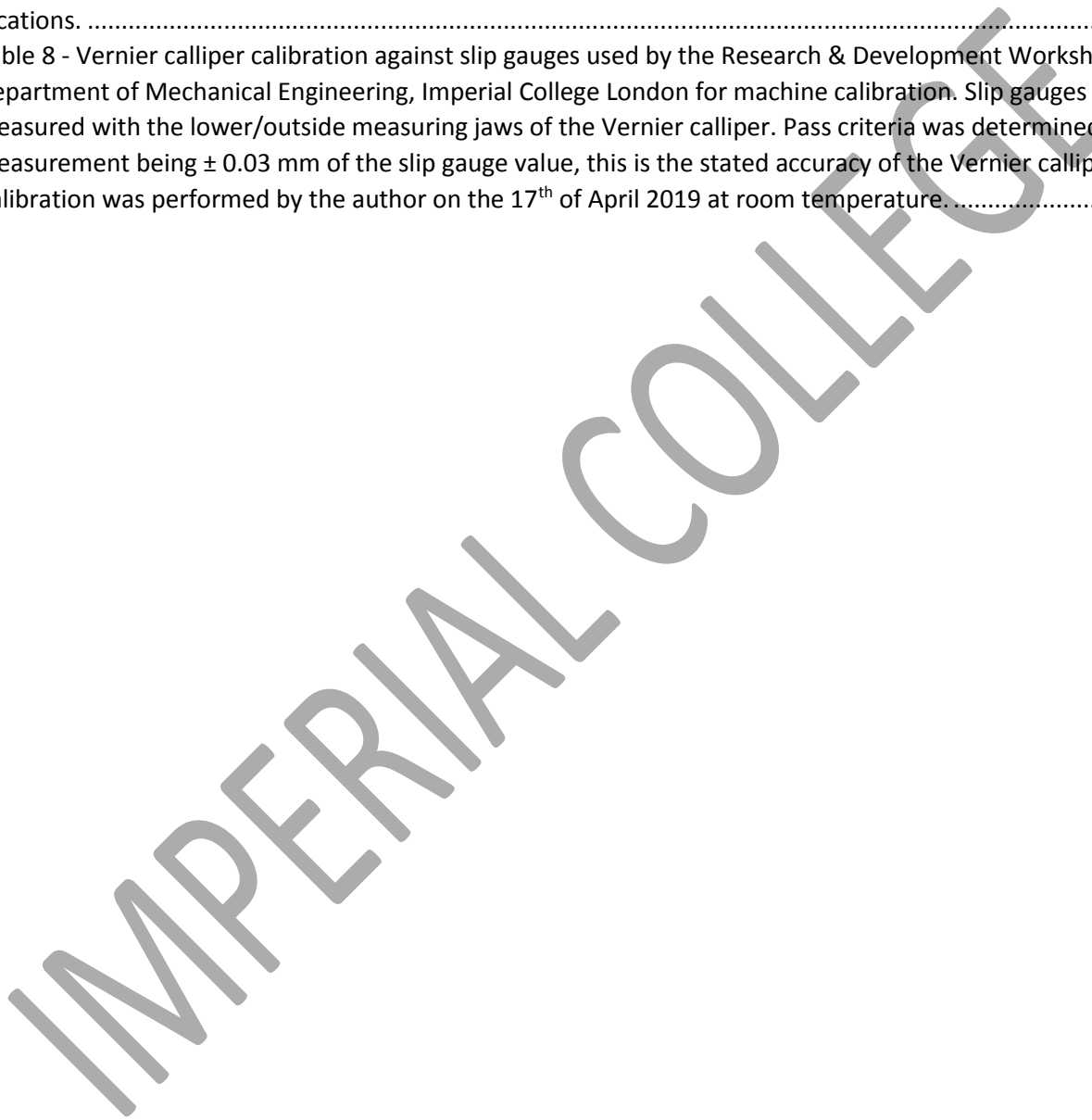

Introduction

We have developed a temporary low cost external fixator, which for the purposes of this report will be known as the 'Mk2 External Fixator'. This report details the comparative testing of the Mk2 External Fixator manufactured at two different locations, these are: Imperial College London, UK and the University of Moratuwa, Sri Lanka (Figure 1). Briefly, this report contains: the design of the Mk2 External Fixator, individual clamp axial compressive tests, clamp interface tests, external fixator system tests and initial discussion of the results of these mechanical tests.



Figure 1 - Moratuwa (top) & Imperial (bottom) manufactured large and small clamps.

Engineering Drawings

Large Clamp

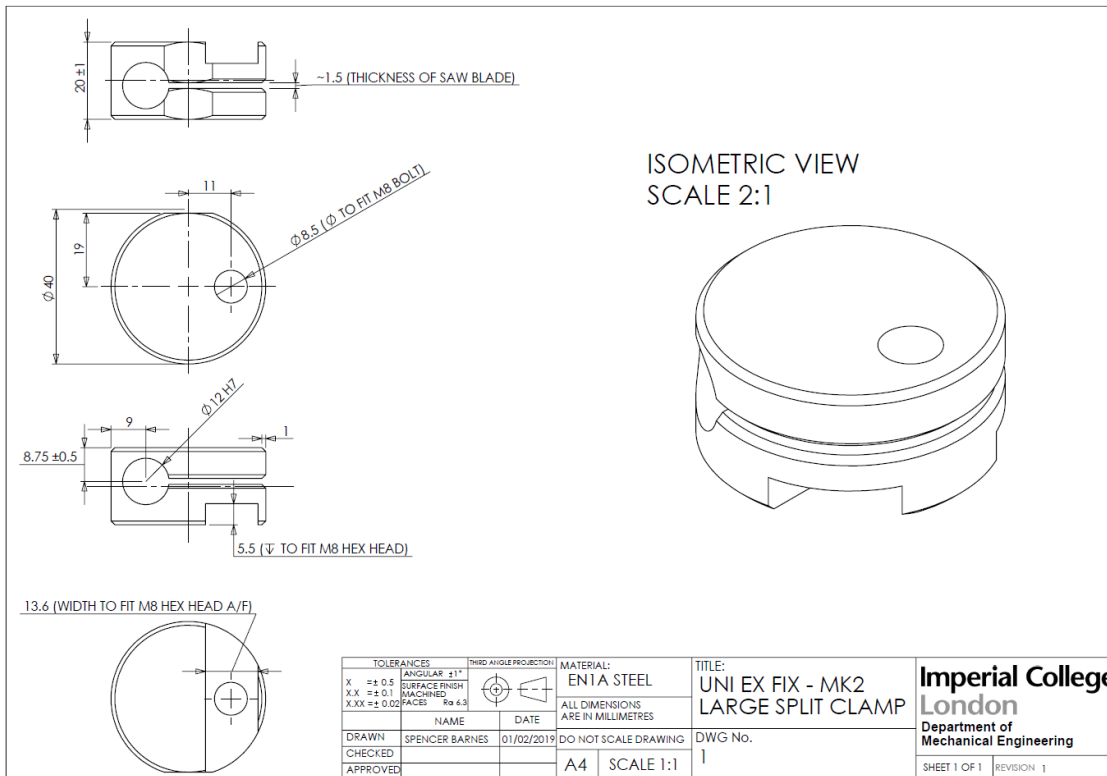

Figure 2 - Large clamp drawing.

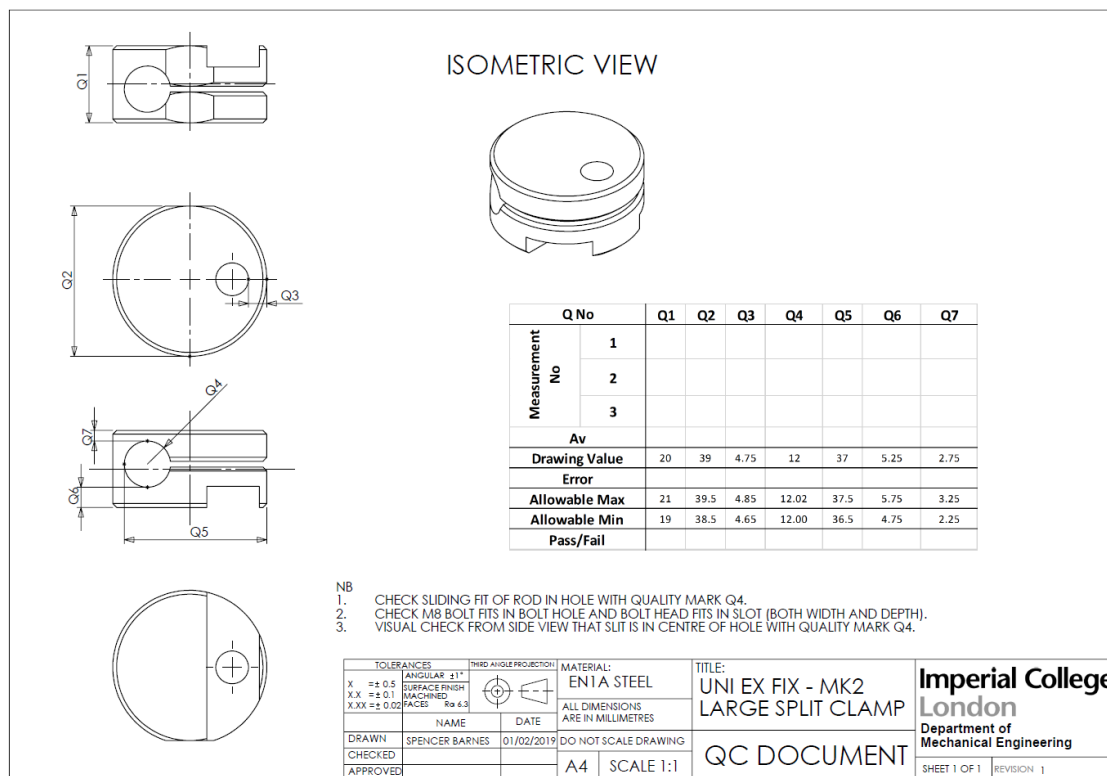

Figure 3- Large clamp quality control document.

Small Clamp

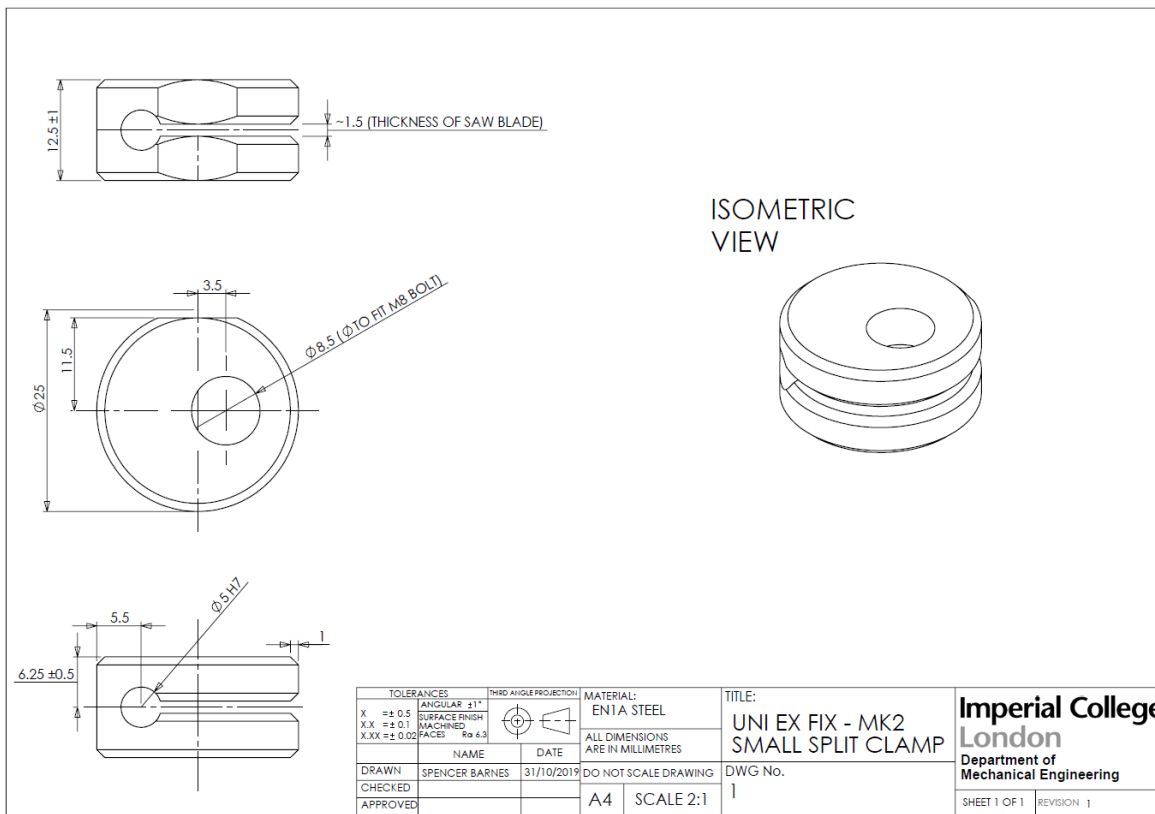

Figure 4 - Small clamp drawing.

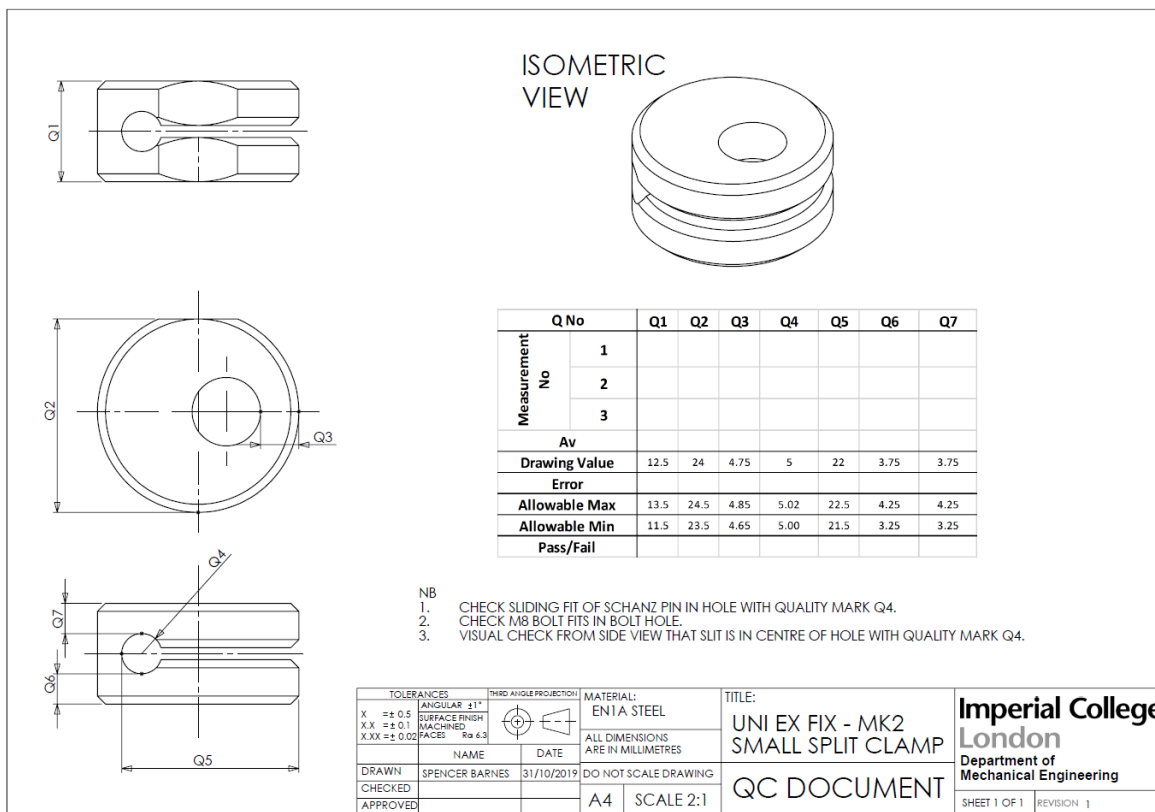

Figure 5 - Small clamp quality control document.

Assembly

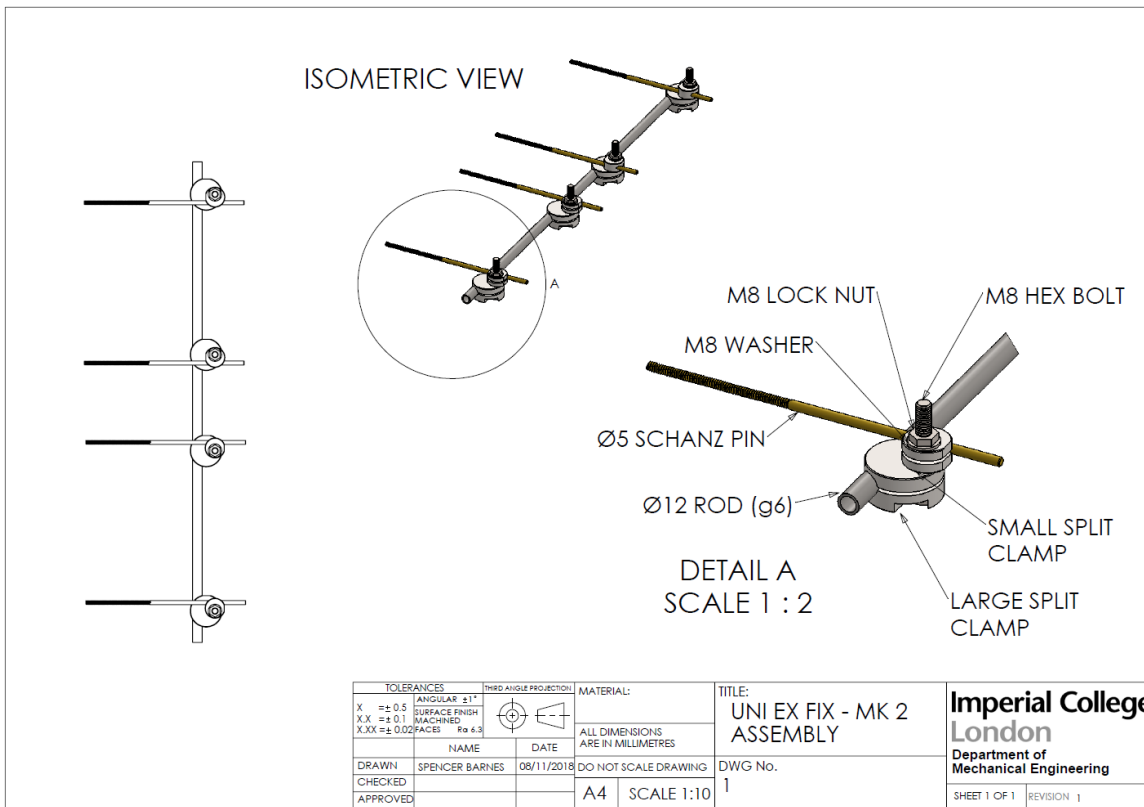

Figure 6 - Mk2 External Fixator assembly drawing.

IMPERIAL

General Methods

All tests were performed on a screw driven mechanical testing machine (Instron 5565) with a 5kN load cell (both Instron, High Wycombe, UK). The calibration certificate for the testing machine can be found in Appendix A. Prior to testing a system compliance test was performed with the actuator head loading directly into the platen. The Instron Bluehill software built in compliance correction subsequently accounted for system compliance in all tests giving corrected extension values.

For the clamp interface tests and external fixator system tests the clamp assemblies were tightened to a torque of 10 Nm using a torque wrench (Norbar TTi50 Torque Wrench, Banbury, UK) prior to testing. The calibration certificate for the torque wrench can be found in Appendix B.

Testing orders and which clamp/system set ups were used for each type of test are detailed in Appendix C.

All tests were performed in accordance with or as close to 'ASTM F1541 – 17 Standard Specification and Test Methods for External Skeletal Fixation Devices' as was possible. At this time no statistical analyses have been conducted.

IMPERIAL COLLEGE

Individual Clamp Compressive Axial Test

To compare the stiffness of the individual clamps manufactured in different locations, compressive axial tests were performed. These tests aimed to simulate the loading conditions the clamps will be subject to when in clinical use.

Methods

A \varnothing 13.5 mm ball bearing was used to apply a quasi-static compressive load to the \varnothing 8.5 mm bolt holes of the clamps. All tests were performed at 5 mm/min and the test order of the clamps was randomised (Table 5). The linear slope stiffness (N/mm) and clamp shut load (N) were recorded from the last repeat (test no 6) for each clamp. $n = 4$ for both clamp types and manufacturer (16 tests in total).

Slit distance was measured with the depth rod of a Vernier calliper, calibration for which can be found in Appendix D. Three measurements were taken for each clamp after which the mean measurement was recorded. The slit distance corresponds to Q5 on the quality document for both the large and small clamp (Figure 3 & Figure 5).

Large Clamp

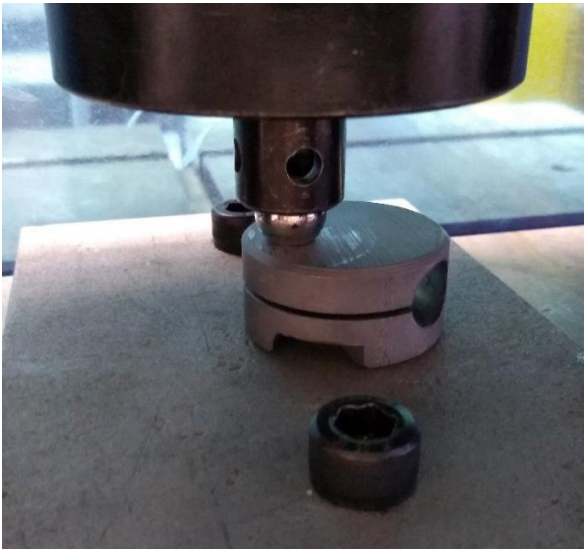

Figure 7 - Axial compression test of an Imperial manufactured large clamp.

Imperial manufactured large clamps were compressed to 450 N five times and then compressed to 2500 N. The Moratuwa manufactured large clamps were compressed to 50 N five times and then compressed to 2500 N. The difference in initial compression load ensured all the large clamps were not subject to plastic deformation.

The Imperial large clamp slope stiffness was recorded as the chord stiffness from 100 N to 400 N. In contrast the Moratuwa large clamp slope stiffness was recorded as the chord stiffness from 10 N to 45 N, this ensured that the stiffness was being measured from the linear portion of the curve.

The clamp shut load was recorded at the point where the stiffness slope drastically increases. Typical load displacement plots, with chord stiffness measurement points (red crosses) and drastic increase in stiffness slope (rhs (right hand side) of graphs), can be seen in Figure 8 & Figure 9.

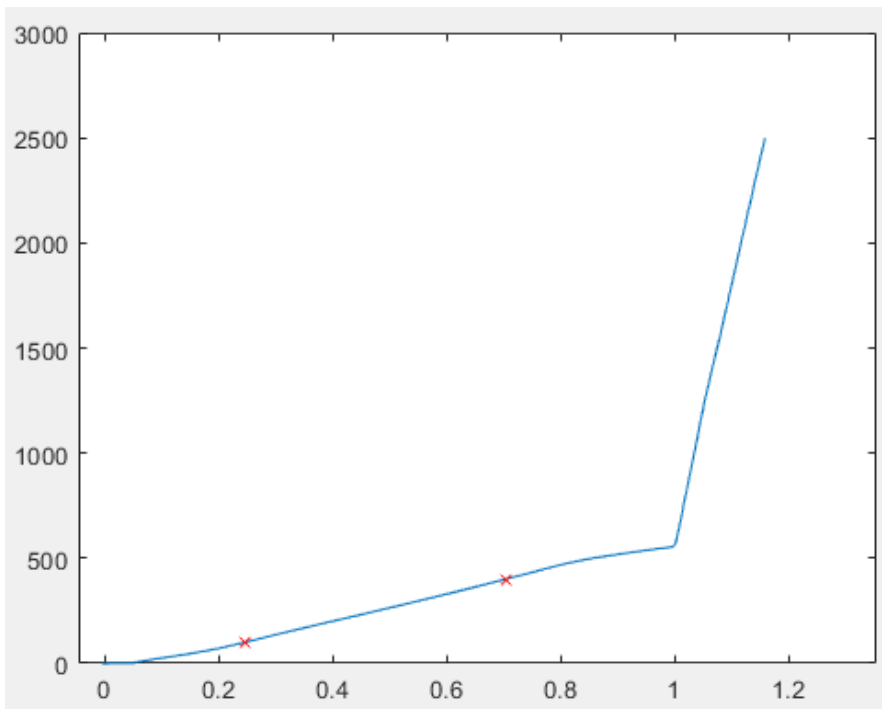

Figure 8 - Imperial large clamp no 3 final compression test.

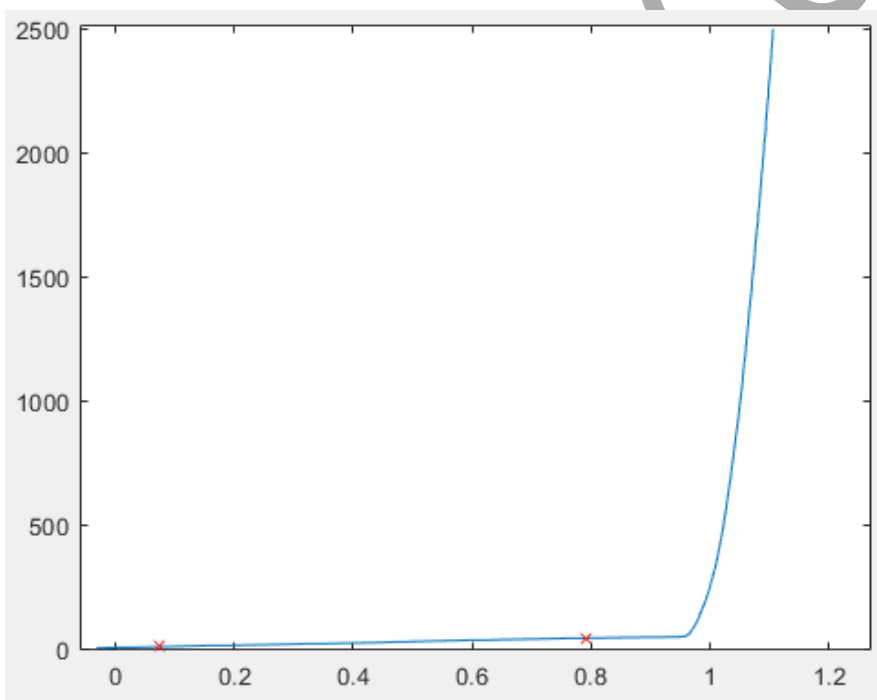

Figure 9 - Moratuwa large clamp no 3 final compression test.

Small Clamp

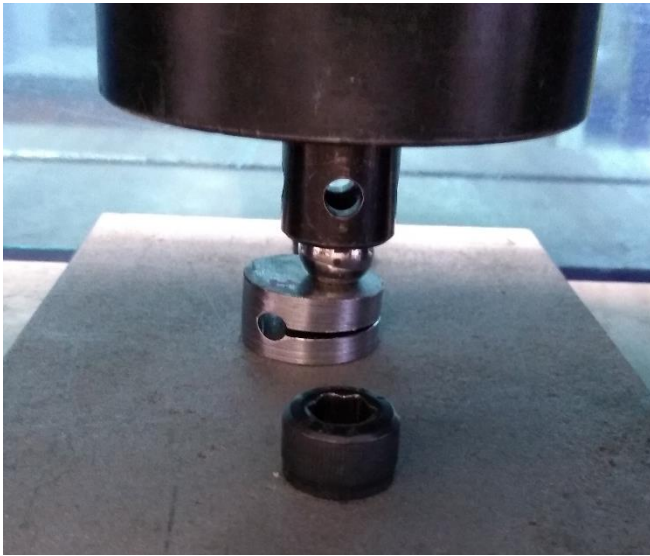

Figure 10 - Axial compression test of a Moratuwa manufactured small clamp.

Imperial manufactured small clamps were compressed to 500 N five times and then compressed to 3000 N. The Moratuwa manufactured small clamps were compressed to 400 N five times and then compressed to 3000 N. The difference in initial compression load ensured all the small clamps were not subject to plastic deformation.

The linear slope stiffness was recorded as the chord stiffness from 100 N to 400 N. The clamp shut load was recorded at the point where the stiffness slope drastically increases. Typical load displacement plots, with chord stiffness measurement points (red crosses) and drastic increase in stiffness slope (rhs of graphs), can be seen in Figure 11 & Figure 12.

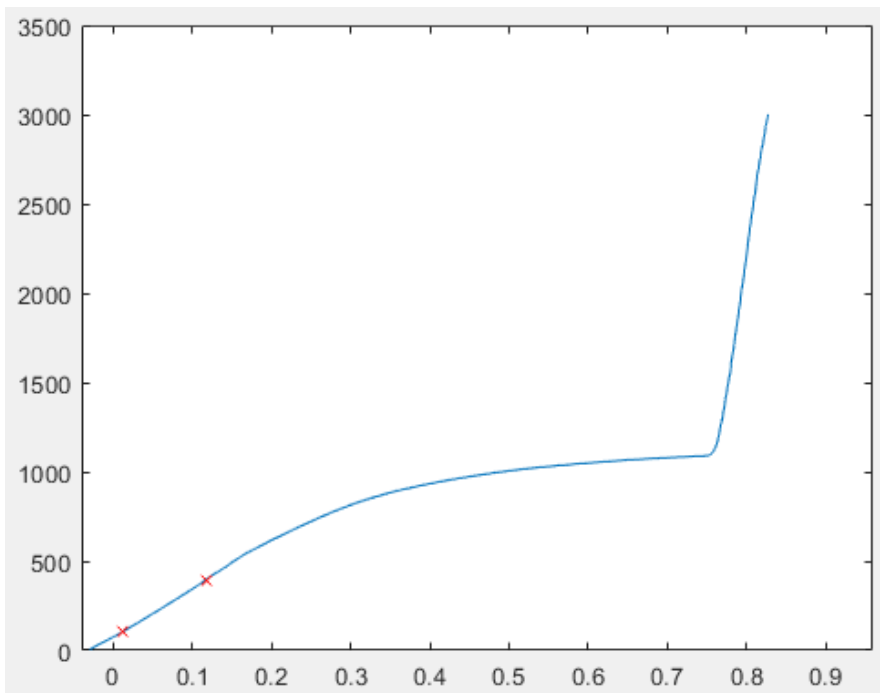

Figure 11 - Imperial small clamp no 2 final compression test.

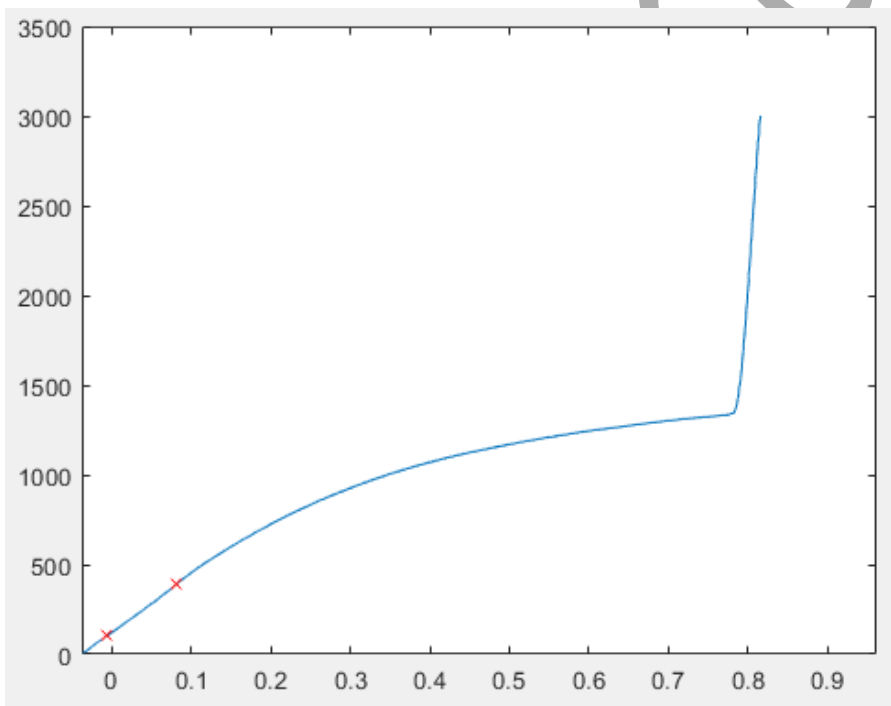

Figure 12 - Moratuwa small clamp no 2 final compression test.

Results

Large Clamp

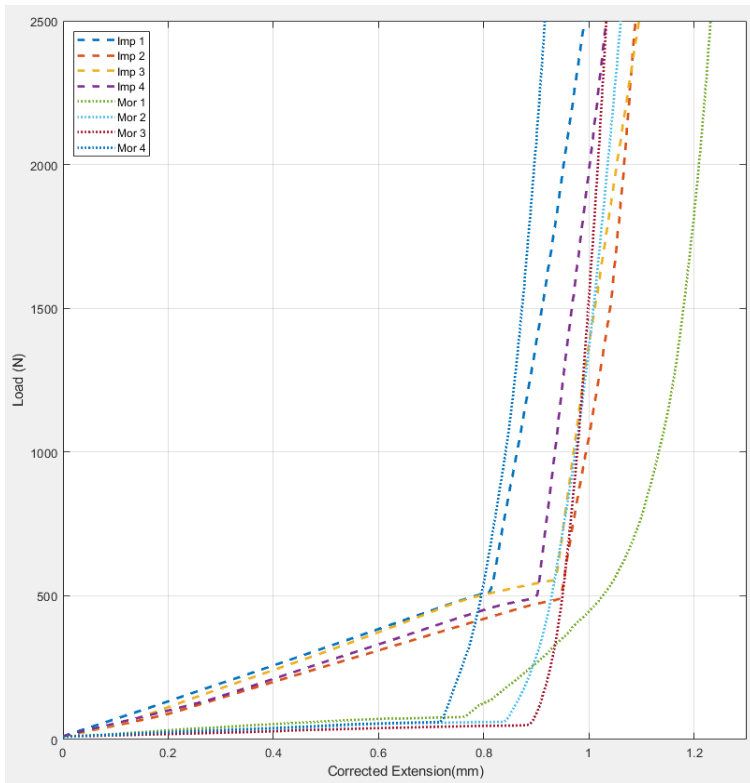

Figure 13 – All large clamp load corrected extension graphs.

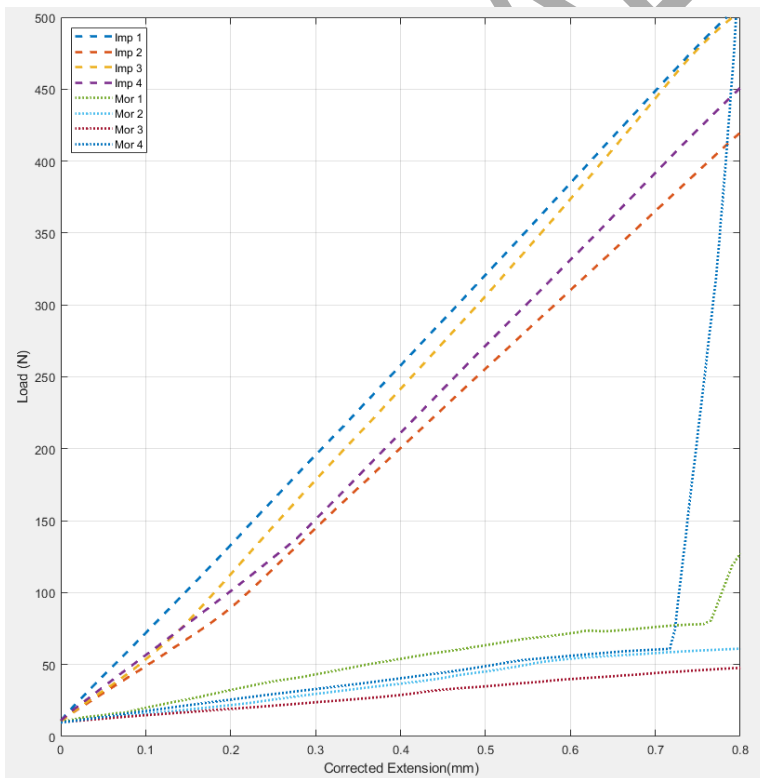

Figure 14 – All large clamp linear region load corrected extension graphs.

Table 1 - Large clamp compressive axial mechanical test results.

Manufacturer	Value	Clamp Shut Load (N)	Stiffness (N/mm)	Slit distance (mm)
Imperial	Mean av	518.6	604.6	37.5
	stdev	34.1	46.3	0.1
Moratuwa	Mean av	73.3	75.8	38.6
	stdev	15.6	23.9	0.5

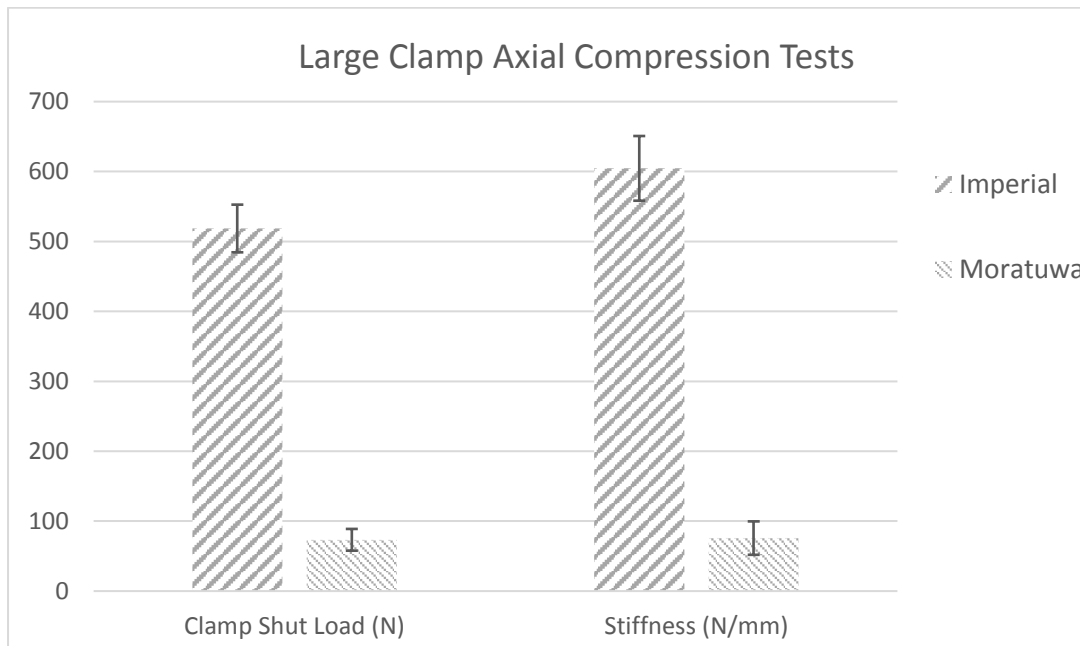

Figure 15 - Large clamp axial compression test bar chart. ± 1 standard deviation error bars.

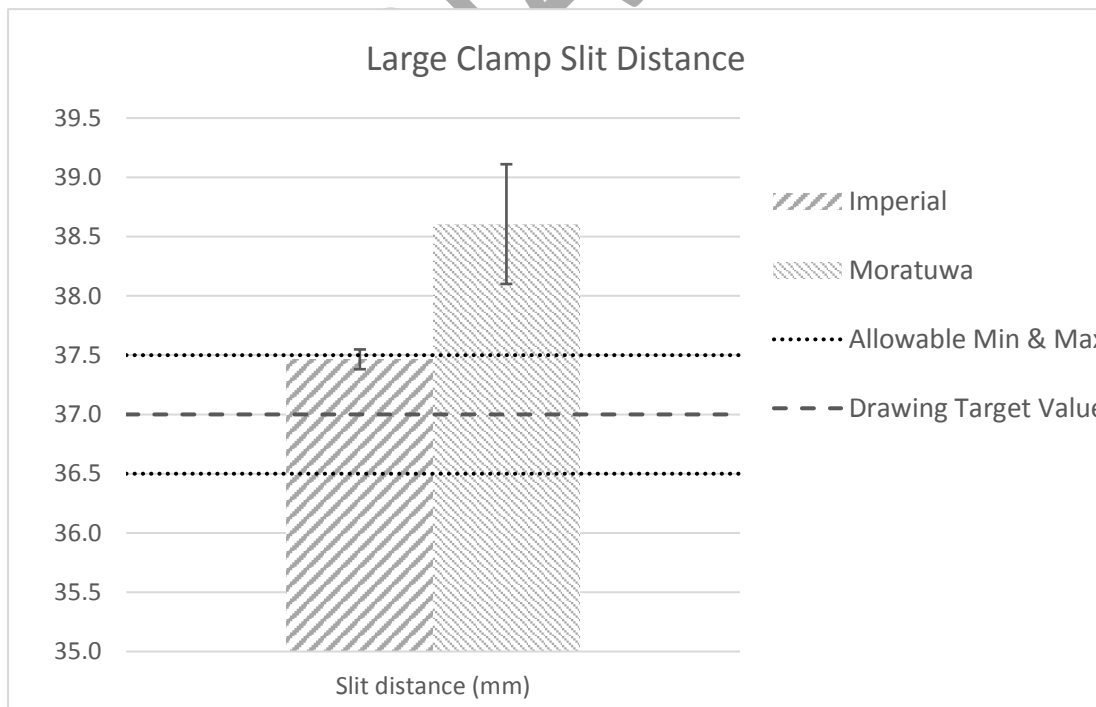

Figure 16 - Large clamp slit distance bar chart. ± 1 standard deviation error bars.

Small Clamp

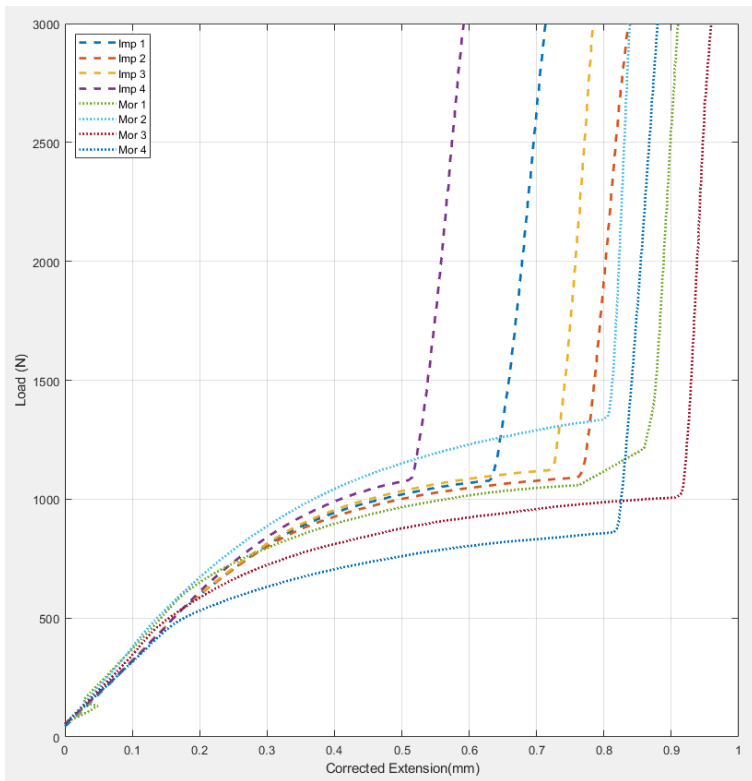

Figure 17 – All small clamp load corrected extension graphs.

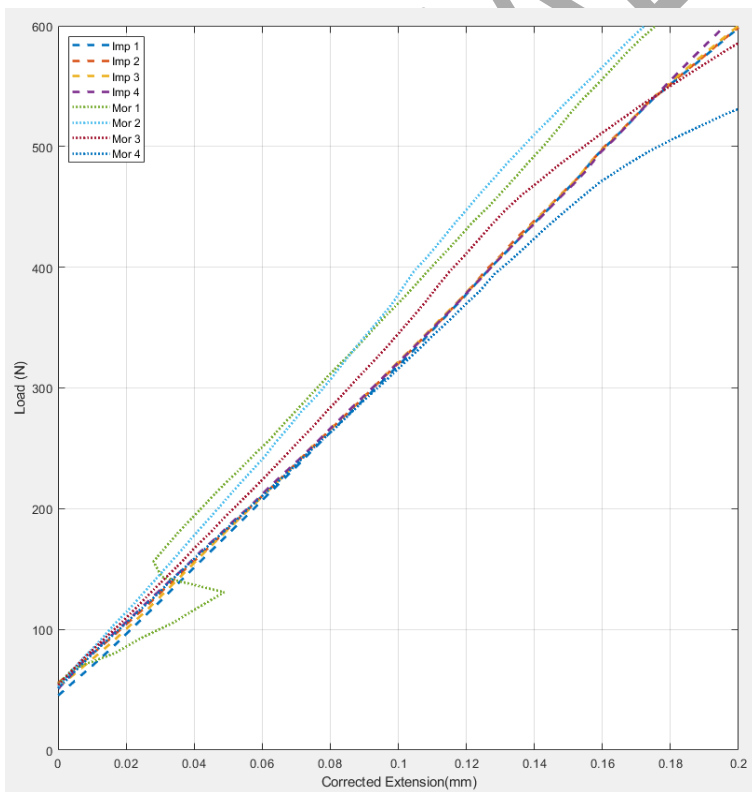

Figure 18 – All small clamp linear region load corrected extension graphs.

Table 2 - Small clamp compressive axial mechanical test results.

Manufacturer	Value	Clamp shut load (N)	Stiffness (N/mm)	Slit distance (mm)
Imperial	Mean av	1106.1	2786.8	21.9
	stdev	23.1	38.6	0.1
Moratuwa	Mean av	1068.3	3013.3	21.7
	stdev	197.2	267.2	0.4

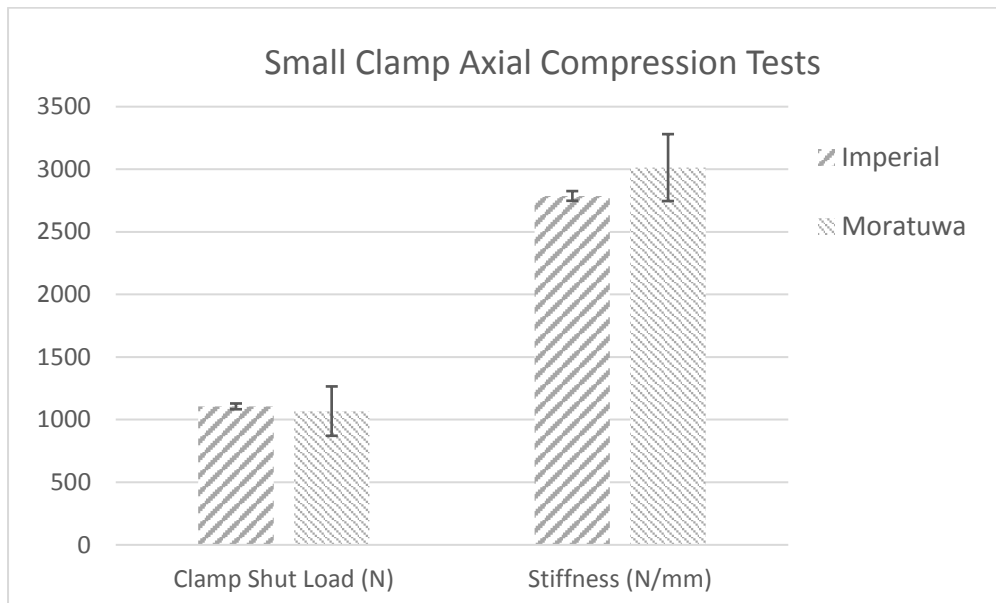

Figure 19 - Small clamp axial compression test bar chart. ± 1 standard deviation error bars.

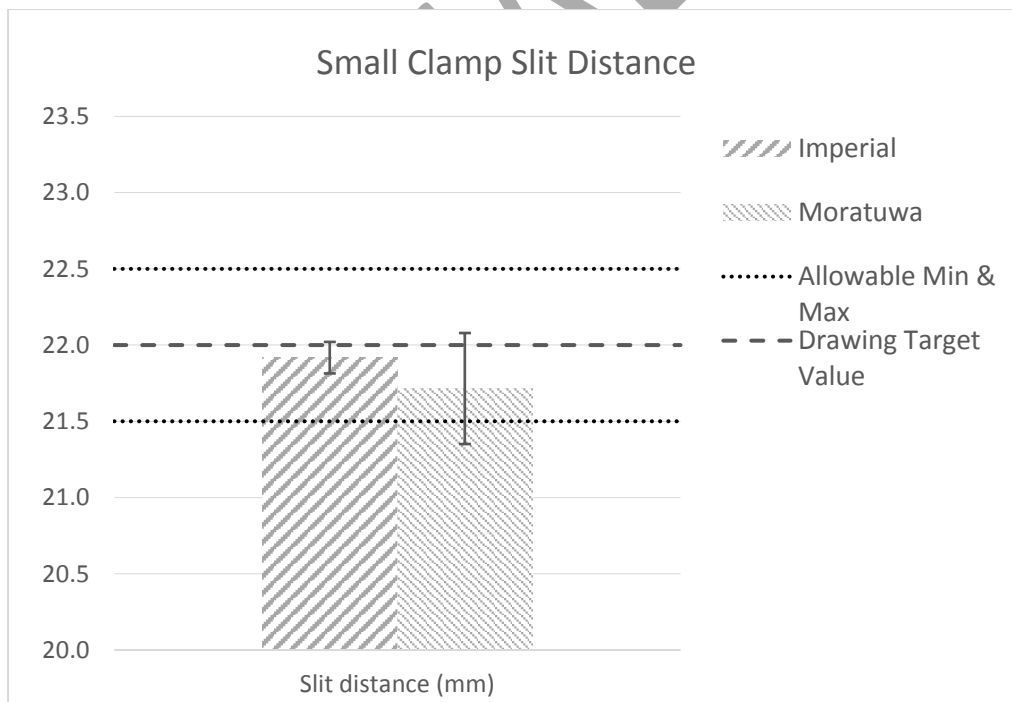

Figure 20 - Small clamp slit distance bar chart. ± 1 standard deviation error bars.

Clamp Interface Tests

To compare the ability of combined large small clamp assemblies manufactured in different locations to resist rotational shear forces, interface tests were performed.

Methods

A custom made fixture was used to apply quasi-static loading 50 mm from the rhs of the large clamp rod to the lhs of the actuator rod (front view - Figure 21). The large clamps, along with small clamps, nuts bolts and washers, were mounted on the same position of the rod and a previously untested 90 mm length section of $\varnothing 5$ mm EN1A steel round bar was used as a substitute for the bone pin/screw for each test. Large and small clamp combinations from each manufacturer were randomised (Table 6). A custom made actuator head, with a convex internal surface, was manufactured using a resin 3d printer (Form 2, Formlabs, Somerville, USA) to apply loading to the $\varnothing 5$ mm round bar without applying a moment to the actuator. n = 4 for both manufacturers (8 tests in total).

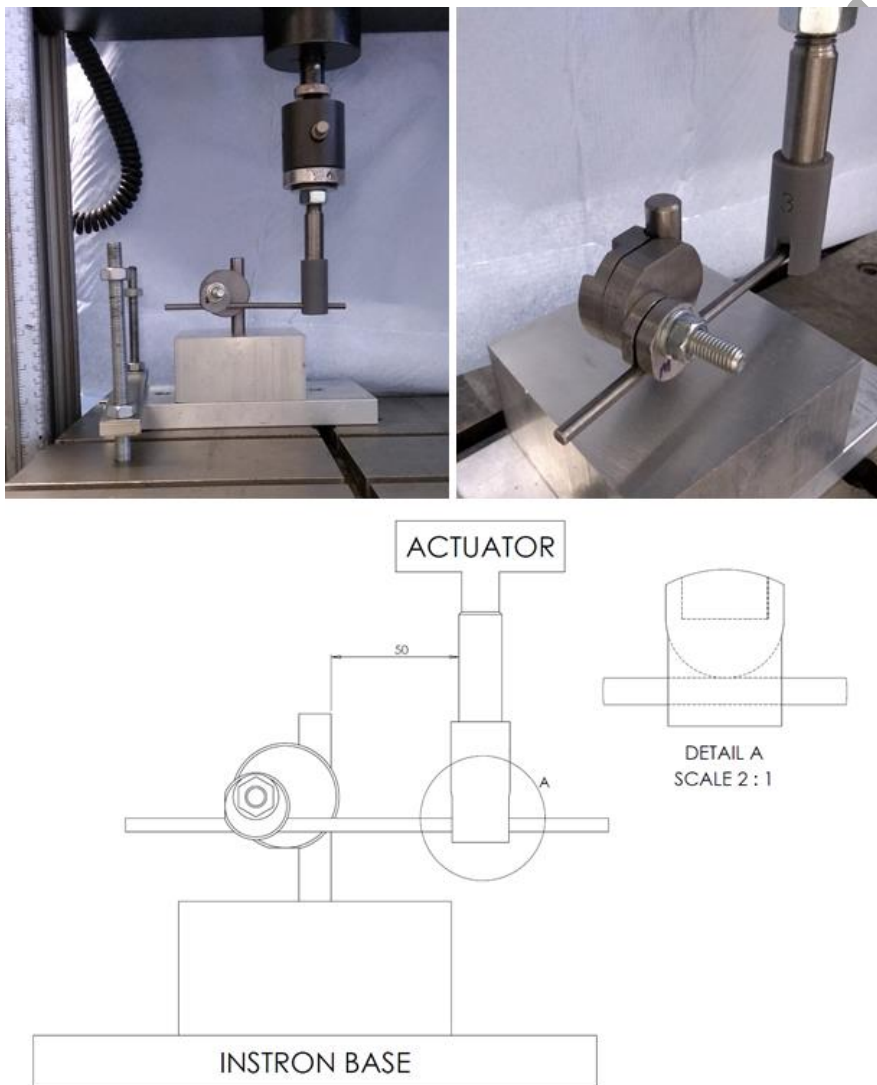

Figure 21 - Interface mechanical test set up. Imperial Mk2 side view (top left), Moratuwa Mk2 isometric view (top right) & CAD drawing (bottom).

The loading rate applied was 10 mm/min. For all tests the interface was preloaded to 5N and then loaded to 60 N six times and then loaded until the interface started to slip. The linear region stiffness was recorded as the chord stiffness from 10 N to 40 N on the last test and the slip load recorded as the point where the gradient of the line decreases and is no longer constant. Typical load displacement plots, with chord stiffness measurement points (red crosses) and decrease in slope stiffness (top rhs of graphs), can be seen in Figure 22 & Figure 23.

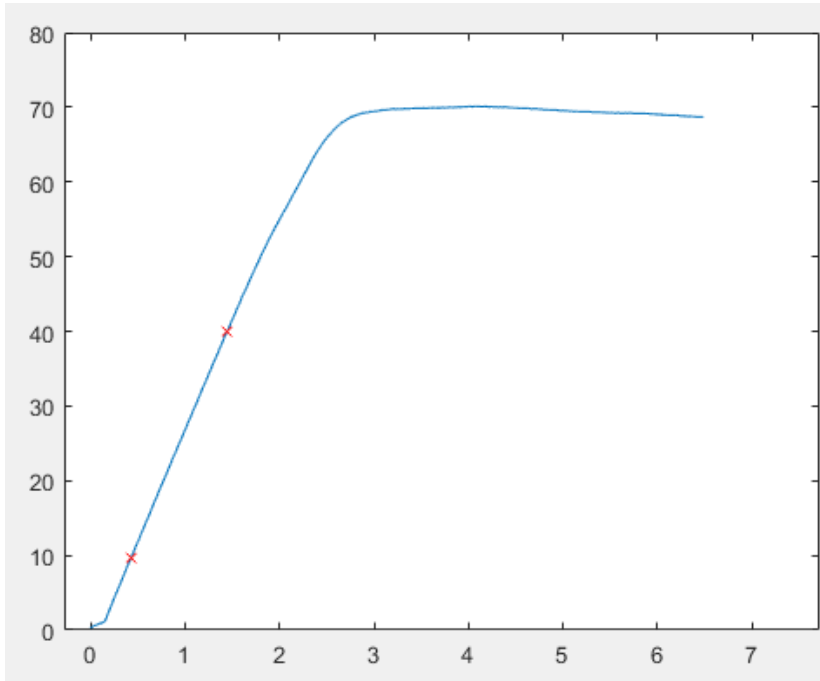

Figure 22 - Imperial interface test no1 (small clamp no4 & large clamp no1) final test.

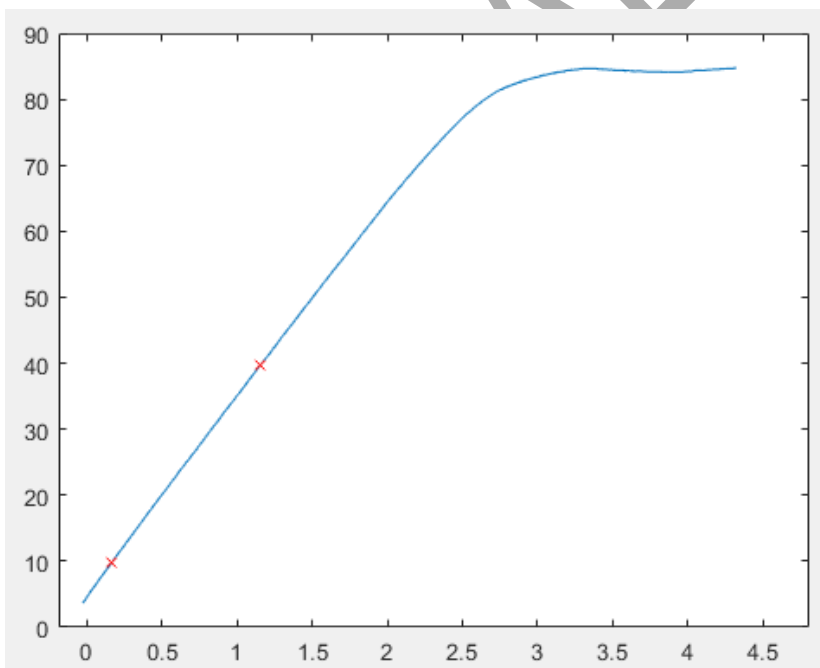

Figure 23 - Moratuwa interface test no4 (small clamp no2 & large clamp no2) final test.

Results

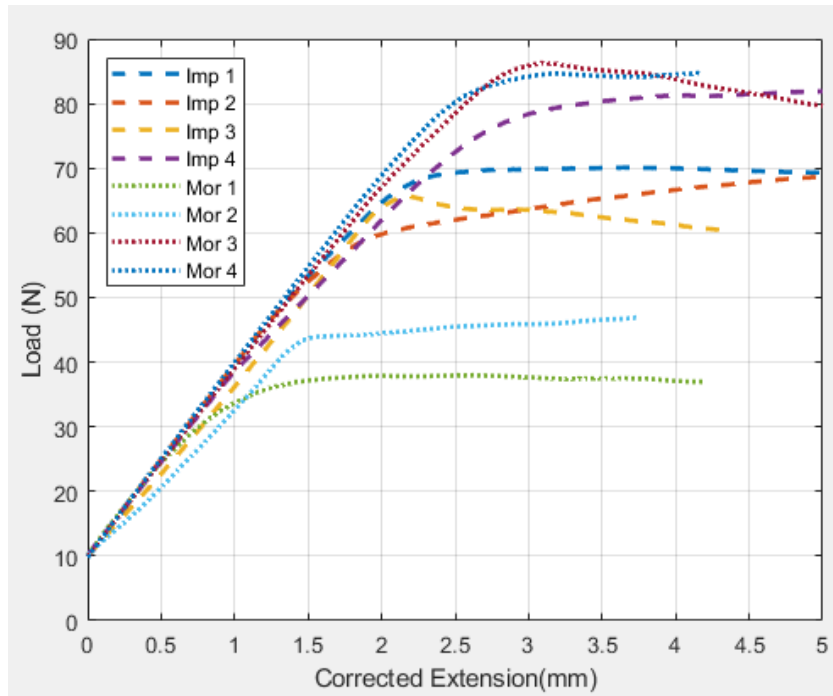

Figure 24 - All clamp interface load corrected extension graphs.

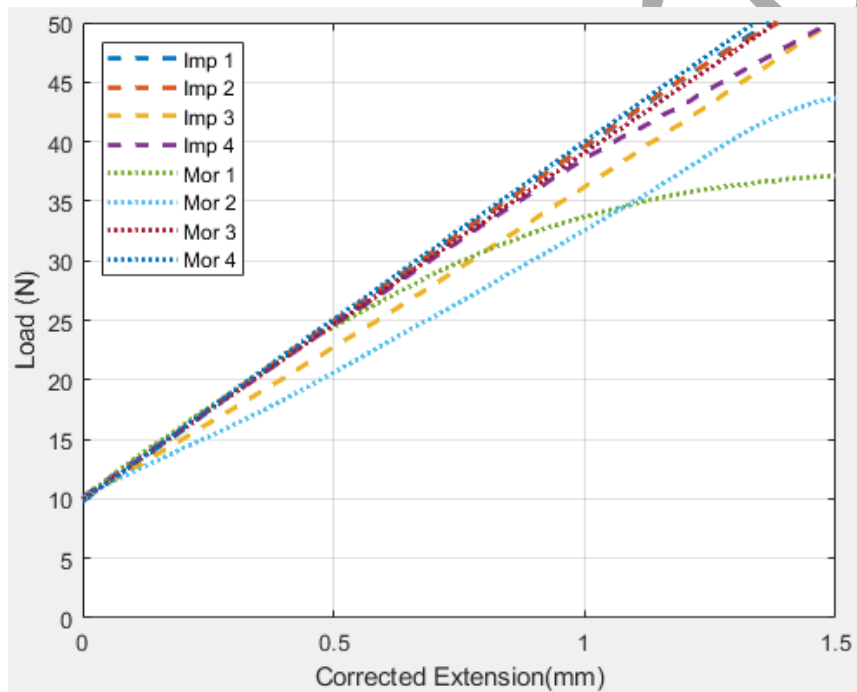

Figure 25 - All linear region clamp interface load corrected extension graphs.

Table 3 - Clamp interface mechanical test results.

Manufacturer	Value	Slip load (N)	Stiffness (N/mm)
Imperial	Mean av	57.5	28.5
	stdev	10.4	1.6
Moratuwa	Mean av	59.5	27.1
	stdev	25.8	3.2

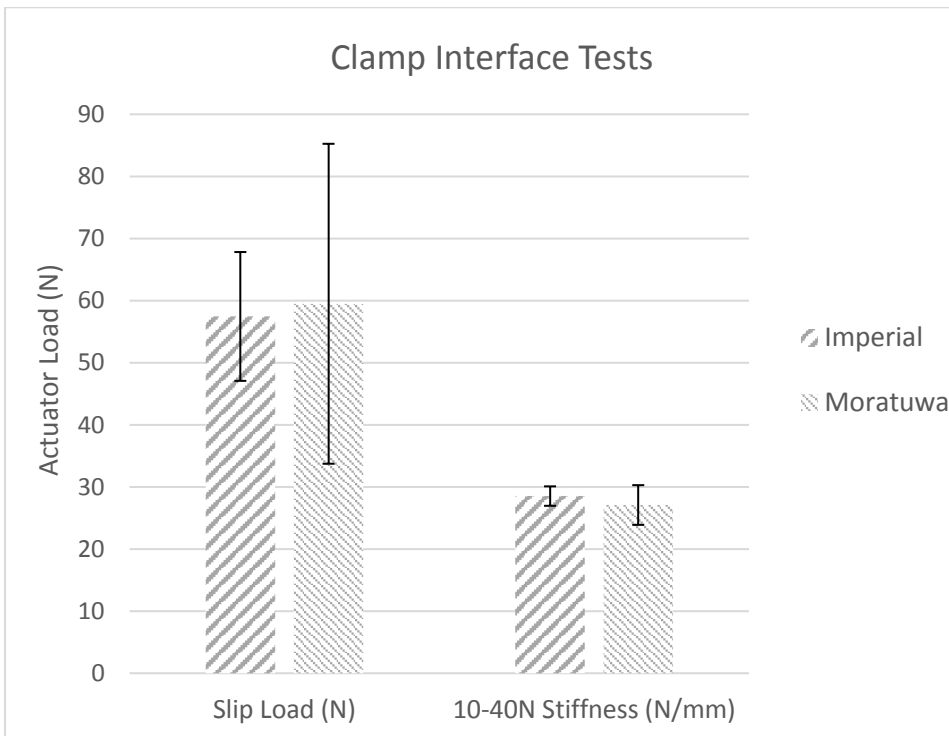

Figure 26 - Clamp interface test result bar chart. ± 1 standard deviation error bars.

System Tests

To compare the overall stiffness of the different fixators, system tests were performed with 4 clamp assemblies stabilising two sections of bone analogues.

Methods

Two \varnothing 19 mm ball bearings were used to apply quasi-static loading through 2 bone analogues (\varnothing 30 mm Acetal rod) stabilised with the Mk2 External Fixator. Two clamp assemblies (one clamp assembly = large clamp, small clamp, bolt, washer, and nut) with \varnothing 5 mm bone pins were used per bone analogue. The same rod (\varnothing 12 mm, 1.5 mm wall thickness steel tube), bone pins and bone analogues were used for each test. Additionally a Stryker Hoffmann 3 temporary external fixator, with \varnothing 11 mm carbon fibre rod, was also tested to serve as a control. To achieve $n = 4$ for each manufacturer the order of the large and small clamps (& clamp combinations for the Hoffmann device) used was interchanged randomly (Table 7 – 12 tests in total).



Figure 27 - System mechanical test set up. Moratuwa Mk2 front view (left), Imperial Mk2 isometric view (middle) & CAD drawing (right).

For all tests the system was preloaded to 20 N and then loaded to 200 N, at 10 mm/min, eight times. The linear region stiffness was recorded as the chord stiffness from 30 N to 190 N on the last test. Typical load displacement plots, with chord stiffness measurement points (red crosses) can be seen in Figure 28, Figure 29 & Figure 30.

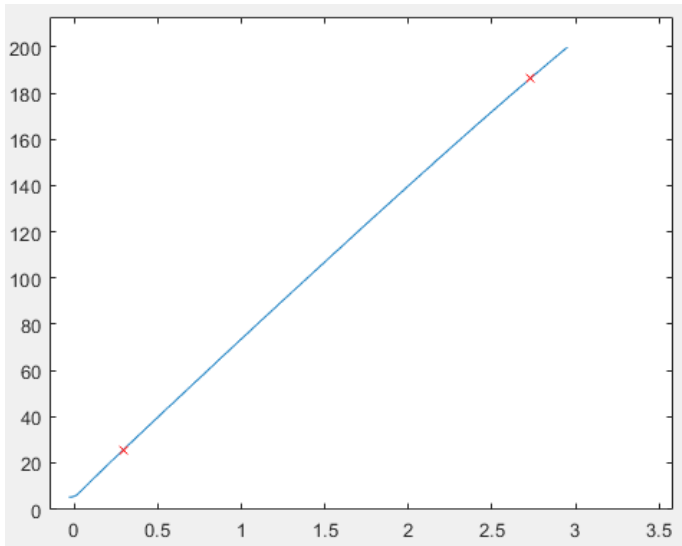

Figure 28 - Imperial system test no1 final test.

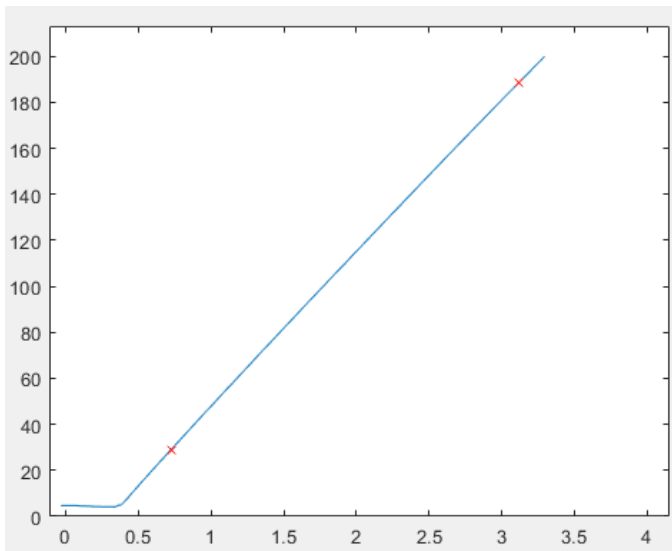

Figure 29 - Moratuwa system test no4 final test.

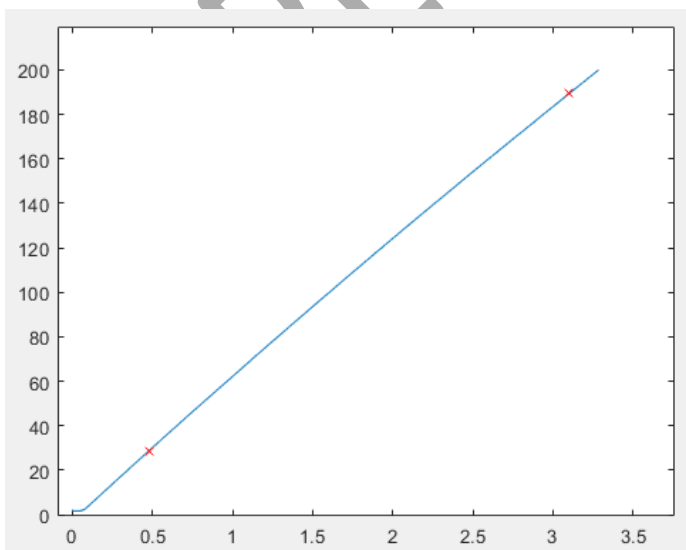

Figure 30 - Stryker system test no2 final test.

Results

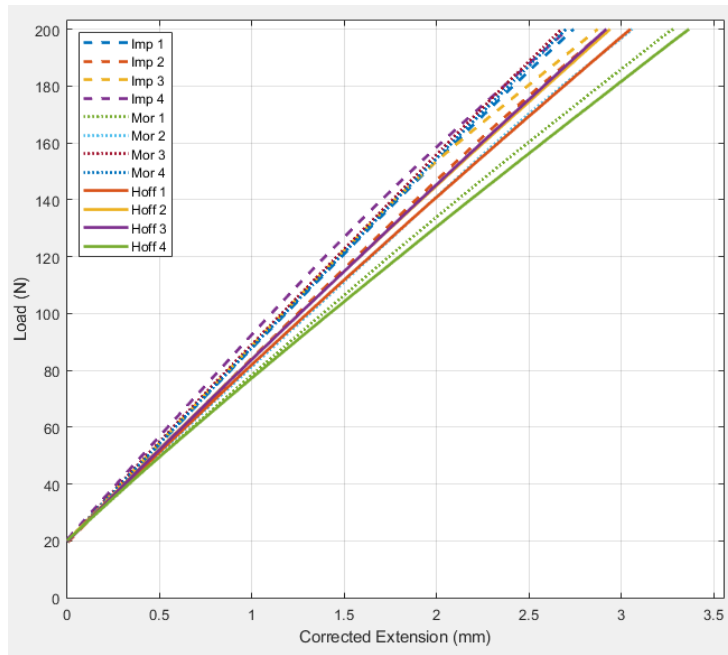

Figure 31 - All system test load corrected extension graphs.

Table 4 - System mechanical test results.

Manufacturer	Value	Stiffness (N/mm)
Imperial	Mean av	64.7
	stdev	2.3
Moratuwa	Mean av	62.0
	stdev	6.0
Stryker	Mean av	59.0
	stdev	3.7

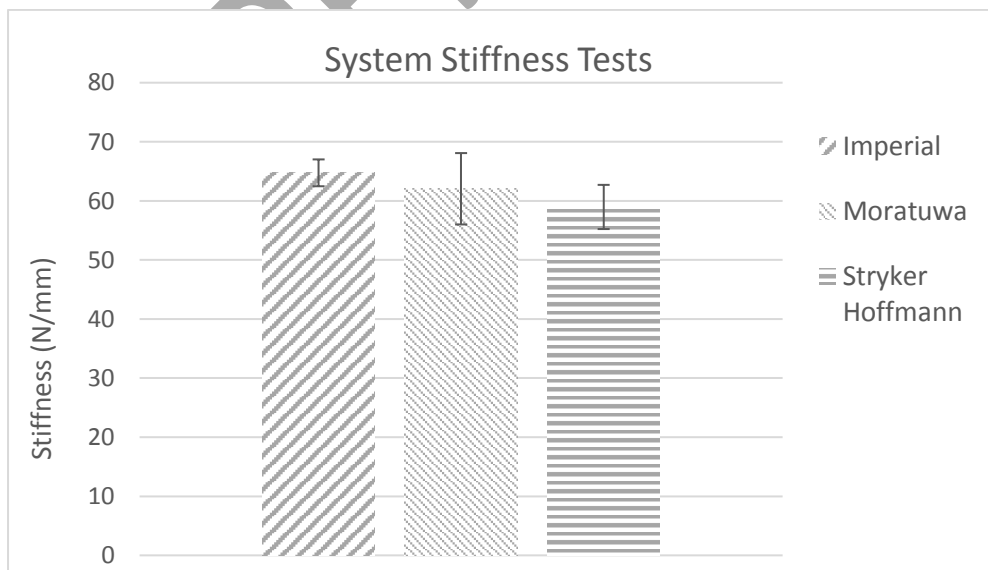

Figure 32- System stiffness test results bar chart. ± 1 standard deviation error bars.

Preliminary Discussion

For the individual clamp compressive tests the large clamps performed very differently between manufacturers (Figure 15), this was in contrast to the small clamps which exhibited similar stiffness and clamp shut loads (Figure 19). The difference between the Imperial and Moratuwa large clamps is due to the difference in slit distance (Q5 - Figure 3) where the Moratuwa manufactured clamp, is on average 1.5 mm away from the target value (Figure 16). This resulted in a thin wall thickness in the Moratuwa large clamps which would account for the different behaviour exhibited in all of the Moratuwa large clamps (Figure 13).

Machining of the $\varnothing 12$ H7 holes for the large clamps requires machining onto a curved surface which can deflect tooling. This should be accounted for in any future machining. Potential correction strategies include, but are not limited to, initially machining a flat into the surface with a slot/end mill and subsequent use of a centre drill (detailed in 'Process 4 – Large Clamp – Milling' manufacturing document).

For both the interface tests and system tests the clamp assemblies and systems performed similarly between manufacturers (Figure 26 and Figure 32). This suggests that the difference in the performance of the Imperial and Moratuwa large clamps has little effect when used in clamping assemblies and in a unilateral system.

In comparison to the Stryker Hoffmann 3 temporary external fixator both manufactured Mk2 External Fixators performed similarly, this result is promising and bodes well for the development of the device.

Limitations

- Q5 was used as the quality measure distance to compare to the individual clamp stiffness and clamp shut load. In future it may be more appropriate to use Q5 - Q3 as the distance to account for variation in machining of the bolt hole (Figure 3 and Figure 5).
- Interface tests exhibited large variations and are dependent on potentially varying conditions at the interface at the time of testing.
- System tests were not to failure, only to 200 N, therefore only initial stiffness can be commented on. As the fixator we are developing is temporary, and not load bearing, high loads are not to be expected.
- The rod used in the Stryker Hoffmann 3 device was $\varnothing 11$ mm solid carbon fibre as opposed to tube $\varnothing 12$ mm, 1.5 mm wall thickness steel.

Other Observations

- All Moratuwa supplied clamps H7 holes (for rod and bone pins for large and small clamps, respectively) were re-reamed prior to testing as the rods and pins did not fit into the clamps. Please check this in future with inspection and hand re-ream post machining of the slit as necessary.
- Entire quality inspection for the Moratuwa clamps was not completed but it was noticed that there was variation in the height of the manufactured clamps (Q1) and locations and diameters of bolt holes (Q3 - Figure 3 and Figure 5).

Appendices

Appendix A – Mechanical Testing Machine Calibration Certificate

CERTIFICATE OF CALIBRATION
 ISSUED BY: INSTRON CALIBRATION LABORATORY
 CERTIFICATE NUMBER:
E265072618101111



Instron Calibration Laboratory
 Coronation Road
 High Wycombe, Buckinghamshire HP12 3SY
 Telephone: +44 (0) 1494 456815
 Fax: +44 (0) 1494 456667
 Email: Calibration_Europe@Instron.com

Page 1 of 5 pages

APPROVED SIGNATORY

Type of Calibration: Force
 Relevant Standard: ISO 7500-1:2015
 Date of Calibration: 26-Jul-2018

Martin Tucker

Digitally signed by Martin Tucker
 DN: cn=UKAS, o=Instron Calibration Laboratory, ou=UK
 Calibration Laboratory, ou=UKAS, ou=UKAS, ou=UKAS,
 cn=Martin Tucker, email=Martin.Tucker@instron.com
 Reason: I affirm to the accuracy and integrity of this
 document
 Date: 2018.08.02 10:40:51 +01'00'

*** CALIBRATION RESULTS ***	
System ID: 5565H1722	Transducer ID: 2525-805/UK891
Indicator 1. - Service Port: Bluehill 3 v3.66.4160 (kN)	
PASSED Class 0.5 - 100% Range in Tension mode (0.1016696 to 5.01848)	
PASSED Class 0.5 - 100% Range in Compression mode (-0.1028979 to -5.028261)	
<i>System Class for a range is derived from assessment of the following: error, repeatability, return to zero, resolution, proving device classification, and reversibility if applicable.</i>	

Customer	
Name:	Imperial College
Location:	Lab 709, Department of Mech Engineering, South Kensington Campus, London, SW7 2AZ
Country:	United Kingdom
P.O./Contract No.:	117646
Contact:	Kiron Athwal
Email:	k.athwal12@imperial.ac.uk

Temperature	
Starting Temperature:	22.1 °C
Final Temperature:	21.4 °C

Machine		Transducer	
Manufacturer:	Instron	Manufacturer:	Instron
Type:	Electro-Mechanical Single Range	Capacity:	5 kN
Year of Mfg.:	Unknown	Type:	Tension/Compression

Methodology
 The assessment of the testing machine was conducted on site at the above customer location in accordance with ISO 7500-1:2015 "Metallic materials -- Calibration and verification of static uniaxial testing machines -- Part 1: Tension/compression testing machines -- Calibration and verification of the force-measuring system" using Instron procedure N011.

Instron CalproCR Version 3.38
 This certificate is issued in accordance with the laboratory accreditation requirements of the United Kingdom Accreditation Service. It provides traceability of measurements to recognized national standards, and to units of measurement realized at the National Physical Laboratory or other recognized national standards laboratories. This certificate may not be reproduced other than in full, except with the prior written approval of the issuing laboratory. UKAS is one of the signatories of the International Laboratory Accreditation Cooperation (ILAC) Arrangement for mutual recognition of calibration certificates.

CERTIFICATE OF CALIBRATION

UKAS ACCREDITED CALIBRATION LABORATORY No. 0019

CERTIFICATE NUMBER:
E265072618101111

Page 2 of 5 pages

System Classification

Prior to verification, a pre-calibration inspection was conducted and the system was found to be in Good condition. The testing machine was verified in the 'As Found' condition with no adjustments or repairs carried out. This is also the 'As Left' condition.

The verification and equipment used conform to a controlled Quality Assurance program which meets the specifications outlined in ISO/IEC 17025:2005.

No mechanically linked accessories were fitted whilst performing this calibration.

Data Summary - Indicator 1. - Service Port: Bluehill 3 v3.66.4160 (kN)

TENSION

% of Range	Relative error of (%)			Repeatability Error (%)	Error Class	Resolution (± kN)	Standard Class
	Run 1	Run 2	Run 3				
100% Range (5 kN)							
0 Return	0.021	0.017	-0.001		0.5	0.00005	
2	0.096	0.049	0.040	0.056	0.5	0.00005	0.5
4	0.127	0.106	0.125	0.021	0.5	0.00005	0.5
4	0.047	-0.038	-0.063	0.110	0.5	0.00005	0.5
7	0.039	-0.004	-0.104	0.143	0.5	0.00005	0.5
10	0.102	0.027	0.003	0.099	0.5	0.00005	0.5
20	0.165	0.293	0.563	0.398	0.5	0.00005	0.5
40	0.157	0.127	0.126	0.031	0.5	0.00005	0.5
60	0.155	0.056	0.146	0.099	0.5	0.00005	0.5
80	0.195	0.142	0.185	0.053	0.5	0.00005	0.5
100	0.287	0.140	0.195	0.147	0.5	0.00005	0.5

Data Summary - Indicator 1. - Service Port: Bluehill 3 v3.66.4160 (kN)

COMPRESSION

% of Range	Relative error of (%)			Repeatability Error (%)	Error Class	Resolution (± kN)	Standard Class
	Run 1	Run 2	Run 3				
100% Range (5 kN)							
0 Return	0.019	0.017	0.016		0.5	0.00005	
2	0.099	0.018	0.028	0.081	0.5	0.00005	0.5
4	0.069	0.034	0.061	0.035	0.5	0.00005	0.5
4	-0.231	-0.211	-0.078	0.153	0.5	0.00005	0.5
7	-0.092	-0.181	-0.119	0.089	0.5	0.00005	0.5
10	-0.122	-0.075	-0.028	0.094	0.5	0.00005	0.5
20	-0.091	-0.037	-0.028	0.063	0.5	0.00005	0.5
40	0.046	-0.096	-0.040	0.142	0.5	0.00005	0.5
60	0.054	-0.007	0.046	0.061	0.5	0.00005	0.5
80	0.090	0.050	0.096	0.046	0.5	0.00005	0.5
100	0.063	0.106	0.127	0.064	0.5	0.00005	0.5

Worst Resolution Class: 0.5 for 100% Range (Indicator 1: Tension), 0.5 for 100% Range (Indicator 1: Compression).

CERTIFICATE OF CALIBRATION

UKAS ACCREDITED CALIBRATION LABORATORY No. 0019

CERTIFICATE NUMBER:
E265072618101111

Page 3 of 5 pages

Data - Indicator 1. - Service Port: Bluehill 3 v3.66.4160 (kN)

TENSION

% of Range	Run 1		Run 2		Run 3		Uncertainty of Measurement*	
	Indicated (kN)	Applied (kN)	Indicated (kN)	Applied (kN)	Indicated (kN)	Applied (kN)	Relative %	(± kN)
100% Range (5 kN)								
0 Return	0.00104		0.00086		-0.00003		0.19	0.00020
2	0.10182	0.10172239	0.10496	0.10490827	0.10171	0.10166962	0.19	0.00038
4	0.20257	0.20231246	0.20356	0.20334403	0.20489	0.2046347	0.19	0.00043
4	0.20763	0.20753171	0.23460	0.23468928	0.22747	0.22761375	0.19	0.00068
7	0.36037	0.36022802	0.35605	0.35606594	0.35190	0.35226804	0.19	0.00098
10	0.51907	0.51854314	0.51525	0.51510942	0.51034	0.51032303	0.19	0.0019
20	1.00800	1.00633891	1.02244	1.01944947	1.03209	1.02631690	0.19	0.0038
40	2.01583	2.01267783	1.99159	1.98905803	2.02563	2.02308303	0.19	0.0058
60	3.00604	3.00137994	3.08218	3.08045946	3.03457	3.03015031	0.19	0.0077
80	3.99509	3.98732466	4.04275	4.03700949	4.07545	4.06791294	0.19	0.0095
100	5.01216	4.99782566	5.02549	5.01847998	5.01976	5.00999974	0.19	

Data - Indicator 1. - Service Port: Bluehill 3 v3.66.4160 (kN)

COMPRESSION

% of Range	Run 1		Run 2		Run 3		Uncertainty of Measurement*	
	Indicated (kN)	Applied (kN)	Indicated (kN)	Applied (kN)	Indicated (kN)	Applied (kN)	Relative %	(± kN)
100% Range (5 kN)								
0 Return	-0.00094		-0.00083		-0.00078		0.19	0.00020
2	-0.10300	-0.10289790	-0.10295	-0.10293149	-0.10298	-0.10295068	0.19	0.00039
4	-0.20518	-0.20503773	-0.20495	-0.20487939	-0.20498	-0.20485540	0.19	0.00042
4	-0.22714	-0.22766577	-0.21971	-0.22017403	-0.20841	-0.20857223	0.19	0.00069
7	-0.35262	-0.35294438	-0.36477	-0.36543062	-0.37513	-0.37557569	0.19	0.00097
10	-0.50383	-0.50444409	-0.51732	-0.51771072	-0.50524	-0.50538056	0.19	0.0019
20	-1.00516	-1.00607878	-1.01262	-1.01299824	-1.02504	-1.02532840	0.19	0.0039
40	-2.03983	-2.03889894	-2.04017	-2.04212455	-2.05452	-2.05533915	0.19	0.0058
60	-3.08702	-3.08534990	-3.09465	-3.09487066	-2.99439	-2.99300375	0.19	0.0077
80	-4.03706	-4.03341970	-4.04302	-4.04101549	-4.03604	-4.03217107	0.19	0.0095
100	-5.01210	-5.00895922	-5.01301	-5.00771060	-5.03467	-5.02826087	0.19	

* The reported expanded uncertainty is based on a standard uncertainty multiplied by a coverage factor $k = 2$, providing a level of confidence of approximately 95%.

The uncertainty stated refers to values obtained during the calibration and makes no allowances for factors such as long term drift, temperature and alignment effects - the influence of such factors should be taken into account by the user of the force-measuring device.

The uncertainty evaluation has been carried out in accordance with UKAS requirements.

CERTIFICATE OF CALIBRATION

UKAS ACCREDITED CALIBRATION LABORATORY No. 0019

CERTIFICATE NUMBER:
E265072618101111

Page 4 of 5 pages

Graphical Data - Indicator 1. - Service Port: Bluehill 3 v3.66.4160 (kN)

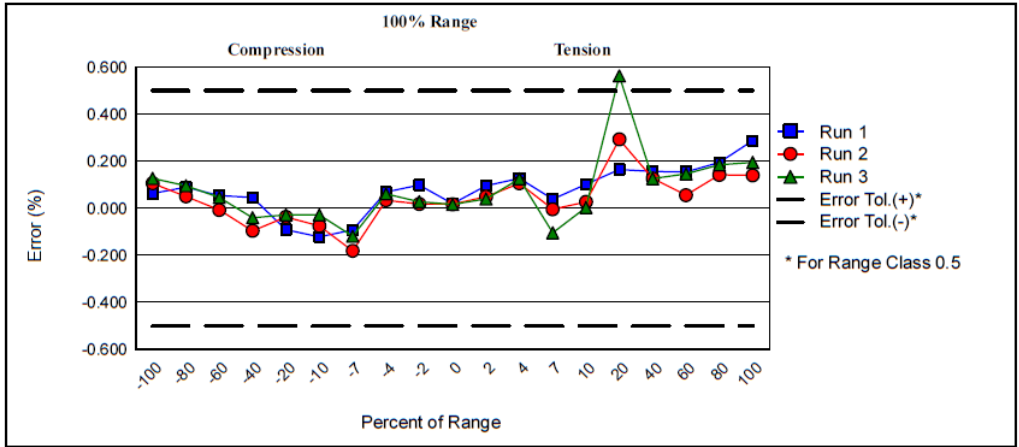

Verification Equipment

The measurement results produced with Instron standards are traceable to the SI (The International System of Units) through internationally recognized National Metrology Institutes (NIST, NPL, PTB, Inmetro, etc.).

Equipment ID	Description	Capacity	Cal Date	Cal Due	Certificate Ref.
N104-1K	load cell	1000 N	16-Dec-2016	17-Dec-2018	E2550115171 75128
N104B-10K	load cell	10000 N	18-Dec-2017	19-Dec-2019	E258121417140720
N104-T	temp. indicator	NA	23-Jan-2018	24-Jan-2020	20170110B
R16-5105	force indicator	NA	04-Jan-2017	05-Jan-2019	E255010617101102

The class of the verification equipment was equal to or better than the class to which this testing machine has been verified.

Verification Equipment Usage

Range Full Scale (%)	Mode	Equipment ID	Percent(s) of Range	Accuracy (+/-)
100	Tension	N104-1K	2/ 4	0.16% of reading
		N104B-10K	4/ 7/ 10/ 20/ 40/ 60/ 80/ 100	0.16% of reading
100	Compression	N104-1K	2/ 4	0.16% of reading
		N104B-10K	4/ 7/ 10/ 20/ 40/ 60/ 80/ 100	0.16% of reading
All	Tension-Compression	N104-T	All	1 °C

The accuracy of the force indicator used with an elastic device is incorporated into the device's stated accuracy.

The accuracy of the verification equipment used was equal to or better than the accuracy indicated in the table above.

Comments

No comments.

CERTIFICATE OF CALIBRATION

UKAS ACCREDITED CALIBRATION LABORATORY No. 0019

CERTIFICATE NUMBER:
E265072618101111

Page 5 of 5 pages

Verified by: Toby Sparkes
Calibration Engineer

NOTE: Clause 9 of ISO 7500-1 states; The time between verifications depends on the type of testing machine, the standard of maintenance and the amount of use. Unless otherwise specified, it is recommended that verification be carried out at intervals not exceeding 12 months. The machine shall in any case be verified if it is moved to a new location necessitating dismantling or if it is subject to major repairs or adjustments.

The Instron Calibration Laboratory is accredited by UKAS to BS/EN/ISO 17025 (General Requirements for the competence of testing and calibration laboratories) to undertake the calibration reported on this certificate.



Appendix B – Torque Wrench Calibration Certificate



Norbar Torque Tools Ltd
 Wildmere Road | Banbury | Oxfordshire OX16 3JU | UK
 T +44 (0)1295 27033 | F +44(0)1295 753643
 E enquiry@norbar.com | www.norbar.com

Declaration of Conformance

This declaration of conformance is in accordance with ISO6789-1:2017

The torque tool identified in this document is declared to be in conformance with ISO 6789-1:2017

Date: **15 Aug 2018** Responsible Person: **R.Burn**
 Model: **13842.RS** Serial No.: **79108297859**

Specified Torque Range from **10.0** to **50.0** N.m.
 Calibration temperature **21°C** at a relative humidity **< 90%**

Target Torque	Maximum Permissible Deviation	Observed Value in Clockwise Direction:				
10.0	9.70	9.92	9.90	9.92	9.93	9.92
	10.30					
30.0	29.10	30.21	30.20	30.21	30.21	30.22
	30.90					
50.0	48.50	50.64	50.29	50.29	50.30	50.30
	51.50					

The above readings were obtained with an interchangeable end of mm from the centre of the plunger to centre of rotation.

The test equipment used in the performance of the above calibration has international traceability through the following calibration laboratory which is UKAS accredited to **ISO 17025:2005**.

Tester Model: **Static TD** Serial No.: **66878**
 Cert No.: **227307** UKAS Laboratory No.: **0256**

The torque measurement device has a maximum relative measurement error of less than or equal to 1.0%, and is less than ¼ of the maximum permissible relative deviation of the torque tool as required by ISO6789-1:2017 (Clause 6.1).

COLLEGE

IMPERI

Appendix C – Testing Orders

Table 5 - Individual clamp testing orders

Large Clamps		Small Clamps	
Testing order	Clamp	Testing order	Clamp
1	Mor3	1	Imp4
2	Imp4	2	Mor2
3	Imp3	3	Mor3
4	Imp2	4	Mor4
5	Mor1	5	Mor1
6	Mor4	6	Imp3
7	Imp1	7	Imp2
8	Mor2	8	Imp1

Table 6 - Clamp interface testing orders and randomised clamp combinations.

Testing order	Interface test ID	Small clamp ID	Large clamp ID	5mm round bar no
1	Imp1	Imp4	Imp1	2
2	Mor3	Mor3	Mor3	5
3	Imp4	Imp3	Imp2	3
4	Imp3	Imp1	Imp3	1
5	Mor4	Mor2	Mor2	7
6	Mor2	Mor1	Mor1	8
7	Imp2	Imp2	Imp4	4
8	Mor1	Mor4	Mor4	6

Table 7 - System testing orders and randomised clamp combinations. Figure 27 details clamp combination locations.

Imperial					Moratuwa					Stryker Hoffmann 3			
Testing Order	System Test ID	Clamp combination location (top down)	Small clamp ID	Large clamp ID	Testing Order	System Test ID	Clamp combination location (top down)	Small clamp ID	Large clamp ID	Testing Order	System Test ID	Combination clamp location (top down)	Combination clamp ID
1	Imp4	1	Imp2	Imp4	1	Mor1	1	Mor2	Mor4	1	Hoff4	1	Hoff4
		2	Imp1	Imp2			2	Mor3	Mor1			2	Hoff3
		3	Imp3	Imp1			3	Mor4	Mor3			3	Hoff2
		4	Imp4	Imp3			4	Mor1	Mor2			4	Hoff1
2	Imp1	1	Imp2	Imp4	2	Mor2	1	Mor4	Mor1	2	Hoff2	1	Hoff1
		2	Imp4	Imp3			2	Mor3	Mor3			2	Hoff3
		3	Imp3	Imp1			3	Mor2	Mor4			3	Hoff2
		4	Imp1	Imp2			4	Mor1	Mor2			4	Hoff4
3	Imp3	1	Imp2	Imp2	3	Mor4	1	Mor1	Mor1	3	Hoff3	1	Hoff1
		2	Imp3	Imp1			2	Mor3	Mor2			2	Hoff2
		3	Imp1	Imp4			3	Mor2	Mor4			3	Hoff3
		4	Imp4	Imp3			4	Mor4	Mor3			4	Hoff4
4	Imp2	1	Imp2	Imp4	4	Mor3	1	Mor2	Mor2	4	Hoff1	1	Hoff4
		2	Imp4	Imp3			2	Mor1	Mor1			2	Hoff1
		3	Imp3	Imp1			3	Mor3	Mor3			3	Hoff2
		4	Imp1	Imp2			4	Mor4	Mor4			4	Hoff3

IMPERIAL COLLEGE

Appendix D – Vernier Calliper Calibration

Table 8 - Vernier calliper calibration against slip gauges used by the Research & Development Workshop, Department of Mechanical Engineering, Imperial College London for machine calibration. Slip gauges were measured with the lower/outside measuring jaws of the Vernier calliper. Pass criteria was determined by the measurement being ± 0.03 mm of the slip gauge value, this is the stated accuracy of the Vernier calliper. Calibration was performed by the author on the 17th of April 2019 at room temperature.

Slip gauge (mm)	Maximum permissible deviation (mm)		Vernier calliper measurement (mm)					Pass/Fail
	Lower	Upper	1	2	3	4	5	
4	3.97	4.03	3.99	3.99	3.99	4.00	4.00	Pass
6	5.97	6.03	6.00	6.00	5.98	6.00	5.99	Pass
8	7.97	8.03	7.99	7.98	7.99	7.99	7.99	Pass
10	9.97	10.03	9.99	9.99	9.99	10.00	10.00	Pass
20	19.97	20.03	19.99	19.99	20.00	19.99	20.00	Pass
30	29.97	30.03	29.99	30.00	30.00	30.01	29.99	Pass
60	59.97	60.03	60.00	60.00	59.99	60.00	60.01	Pass