

Imperial College
London



THE ROYAL BRITISH LEGION

CENTRE FOR BLAST INJURY STUDIES

AT IMPERIAL COLLEGE LONDON



2017

CBIS Annual Report



The Royal British Legion

Centre for Blast Injury Studies

at Imperial College London

May 2018

Centre for Blast Injury Studies Annual Report

**The Royal British Legion Centre for Blast Injury Studies
at Imperial College London**

www.imperial.ac.uk/blast-injury

London, May 2018

Contents

Introduction from Centre Director.....	1
Book Review: 'A Heavy Reckoning: War, Medicine and Survival in Afghanistan and Beyond'.....	4
Staffing & Facilities.....	6
Being a Researcher in CBIS.....	13
Alumni	16
Education	17
Communication of the Work.....	20
Exemplar Research Findings.....	32
In the Spotlight.....	45

Invited Foreword

This has been another very successful year for The Royal British Legion Centre for Blast Injury Studies at Imperial College London. The Centre continues to grow, both in the number of members but also in the number of international collaborations and networks formed. As Director General of The Royal British Legion, I have the pleasure of seeing the extraordinary work and progress achieved by members of the Centre as well as how this impacts on our veterans. As The Royal British Legion's only research centre, we are incredibly proud of its members and value the strong relationship we have with them. Ultimately, we are all working towards the same goal of supporting the Armed Forces community.

One of the key achievements of 2017 was the intake of the largest cohort of PhD students in the history of the Centre. Coupled with the involvement of many Centre members in undergraduate and masters courses, the Centre demonstrates its commitment to training the future leaders in the field of blast injury research. The students, as with other Centre members, represent the multidisciplinary nature of the Centre with backgrounds in engineering, biology and nursing and also with links to the military. The Royal British Legion are committed to continuing to build on this foundation of training, at all levels.

The research produced and published by the Centre is incredibly important to advancing the understanding of blast injury and ultimately how to mitigate, prevent and treat it. With a broad research base, members of the Centre innovate and drive progress in areas such as hearing loss, heterotopic ossification, traumatic brain injury, musculoskeletal injury and rehabilitation. Events such as the 2017 Networking and Research Update Event provide the perfect platform for this research to be disseminated, and importantly for future collaborations and ideas to be discussed.

The Centre's involvement in the Imperial Festival weekend is also noteworthy. Engaging the public in the work of the Centre and the people it is trying to help is a wonderful opportunity. The public regularly see reports of blast injuries on the news, but understanding the true effects of such injuries, and knowing that research groups are working to improve treatment and rehabilitation for those injured, as well as trying to reduce the impact of blast events is crucial. This is an important subject with which we should engage the public.

A final highlight of 2017 was the publishing of Dr Emily Mayhew's book 'A Heavy Reckoning: War, Medicine and Survival in Afghanistan and Beyond'. The book thoughtfully explains the journey of so many military personnel during and following the conflict in Afghanistan and links these to other conflicts within the last century. It emphasises the important work of the Centre, but also that there is yet much that we do not understand. Our ongoing commitment to the Centre for Blast Injury Studies hopes to help reduce the unknown and to increase our knowledge to support the Armed Forces.

I am proud that we at The Royal British Legion can fund the Centre for Blast Injury Studies and hope that as you read this annual report, you will be as impressed as we are by the incredible work of its members.

Charles Byrne

Director General, The Royal British Legion

Introduction from Centre Director

This annual report represents the sixth in series. It celebrates the successes in the Centre during 2017, including research outputs and achievements, and engaging the public with our work - an aspect which we consider to be very important. Some of these successes have been highlighted in Figures 1 and 2 over the page.

This year, the Centre has welcomed a number of new members, including PhD students, postdoctoral researchers and administrative staff. We have seen our largest intake of new PhD students and welcome the opportunity to train future leaders in blast injury research. The PhD cohort will receive training in various different techniques during their time in the Centre, but they will also be engaged in many of the Centre's wider activities. Dissemination of information is important and there will be regular opportunities for the students to talk about their work, whether that is to the public, to key stakeholders, or to other members of the Centre. Activities that bring all Centre members together is an important way of building up the links between the PhD cohort members, particularly when they are based in different departments and campuses.

As well as welcoming new members to the Centre, we have also bid farewell to a handful of members who have moved on to exciting new roles in other departments within Imperial College London or at different organisations. We wish them all the best in their endeavours and look forward to continuing close working relationships and collaborations in the future.

I also want to take this opportunity to highlight the close links that have been established between the Centre in the United Kingdom and colleagues working towards similar goals in various organisations within the United States of America. This was particularly fruitful at the Centre's Annual Networking and Research Update Event where numerous colleagues from the United States attended, many also presenting their work either as a poster or at the podium. This is a relationship which we hope to build on further over the coming years.

A significant amount of this report is dedicated to the research outputs of the Centre. We highlight the input we have into educating people about blast injury, be it through undergraduate or postgraduate courses or through hands-on experience of research within the laboratories. We also discuss the publications that have come from the Centre; predominately journal articles which we make open access, but also a number of books and book chapters. I want to highlight one book in particular which has received excellent reviews since its publication in June; Dr Emily Mayhew's 'A Heavy Reckoning: War, Medicine and Survival in Afghanistan and Beyond'. This is not an academic textbook, but is real life accounts of injuries sustained in Afghanistan (and other conflicts). The book covers stories of the injured, the people that treated them, their families and those who conduct research to try and understand more about blast injury (hopefully helping those previously injured, but also those to come). If you want to understand more about blast injuries and why we work so hard within the Centre – this book will show you why.

Alongside the daily research, Centre members also invest their time in discussing their work with wider audiences at subject specific meetings and conferences, all of which are incredibly important for information dissemination. As well as discussing the work with fellow scientists and engineers, we also want to inspire the next generation of researchers and therefore events such as Imperial Festival are so valuable.

As ever, we want to thank The Royal British Legion for their ongoing financial support of the Centre, but also their engagement in the work we do and our outputs. Additionally, we are incredibly lucky to have support from the Ministry of Defence and Imperial College London. We were honoured to

have been named as one of Imperial College London's Centres of Excellence, highlighting the leading multidisciplinary nature of our work. It has been a very successful year for the Centre for Blast Injury Studies and we look forward to continuing this into and beyond 2018.

Professor Anthony M J Bull FREng

Director, The Royal British Legion Centre for Blast Injury Studies at Imperial College London



Figure 1: 2017: A Year in Pictures

Clockwise from top left: a) Centre members help the public through various exercises at the Centre's Imperial Festival Stand; b) a Centre coffee morning where members can discuss ongoing work and successes; c) Dr Emily Mayhew's book 'A Heavy Reckoning: War, Medicine and Survival in Afghanistan and Beyond'; d) the 2017 Annual Networking and Research Update Event organising committee; e) one of the many publications from the Centre during 2017; f) researchers using the shock tube facility for research into blast traumatic brain injury and; g) Chelsea Pensioners networking with other delegates at the Networking and Research Update Event.

2017: A YEAR IN NUMBERS

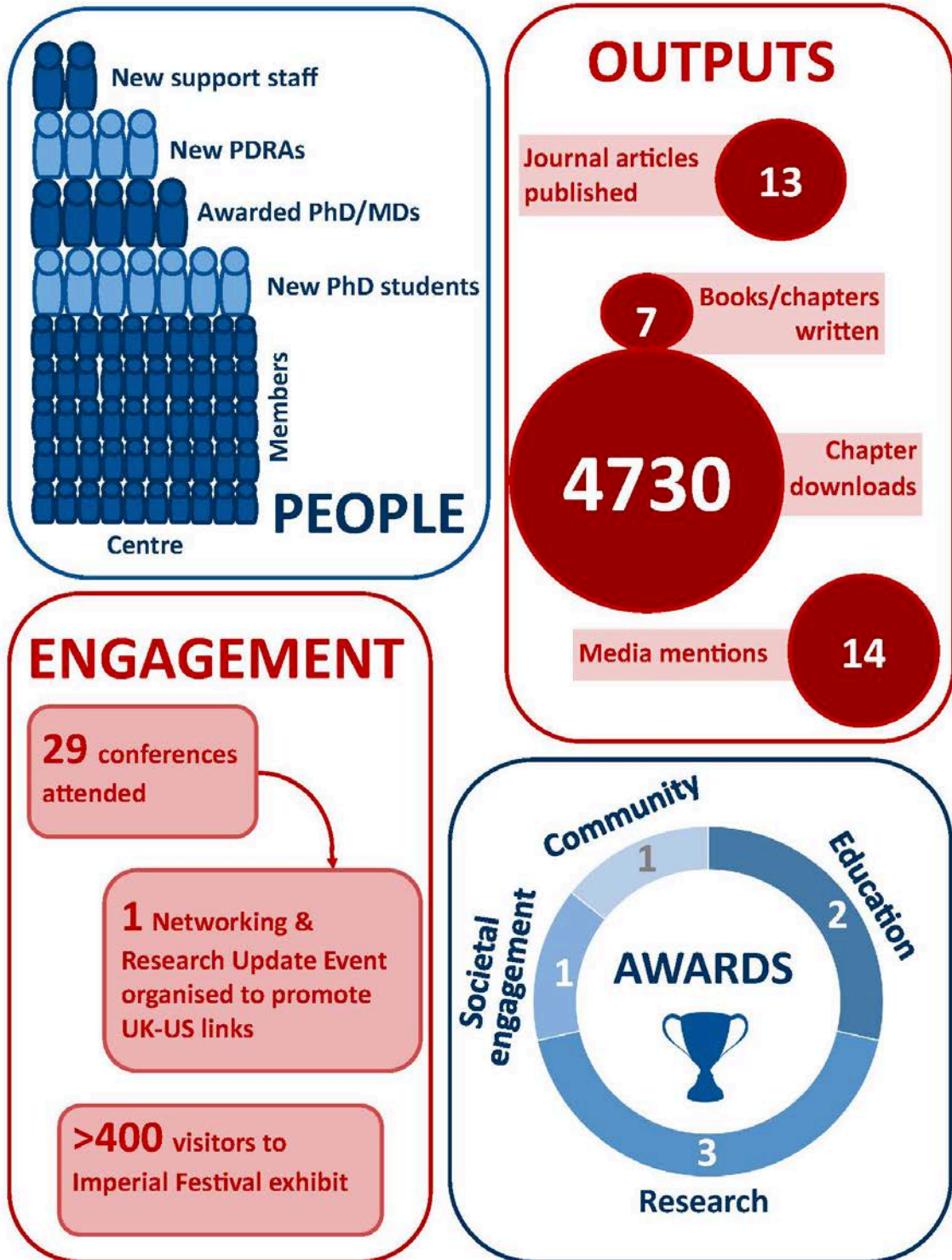
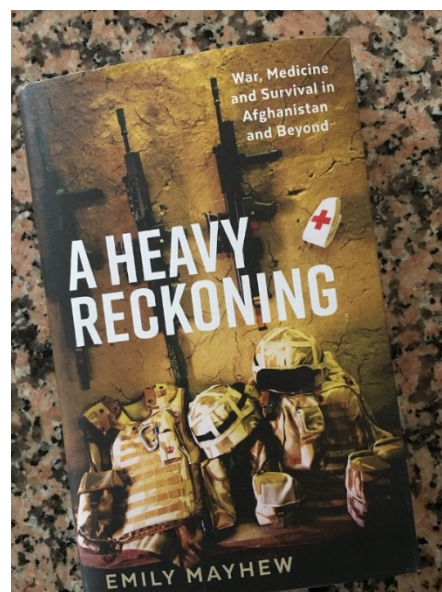

Figure 2: 2017: A Year in Numbers

This infographic provides an overview of the Centre's changes and its achievements across 2017.

Book Review: 'A Heavy Reckoning: War, Medicine and Survival in Afghanistan and Beyond'

Our historian in residence, Dr Emily Mayhew, published "A Heavy Reckoning: War, Medicine and Survival in Afghanistan and beyond" in June 2017. Commissioned by the Wellcome Trust, the book was written using material from the scientists and researchers in the Centre for Blast Injury Studies and is the final part of Dr Mayhew's "Wounded" trilogy which looks at the infliction and outcomes of severe military casualty in wars of the 20th and 21st century. The paperback was published in March 2018, alongside a reissue of her work on burns casualties in the RAF during the Second World War, "The Guinea Pig Club".



"A Heavy Reckoning" provides a vivid description of blast injuries from Afghanistan, with links made to other wars across the last century. It takes the reader through the continuum of care provided to military casualties during the conflict (2001-2014), introducing the vast numbers of personnel involved in trying to save as many lives as possible. Descriptions of the numerous different roles engaged in the care pathway shows the breadth of support and engagement in caring for the injured. These roles included Team Medics, Combat Medical Technicians (CMTs), Medical Emergency Response Teams (MERT), Camp Bastion Medics, Critical Care staff (including the Critical Care Air Support Team (CCAST)), Queen Elizabeth Hospital staff (Birmingham) and those at Headley Court. These multidisciplinary teams included expertise in surgery (trauma, orthopaedics, plastics etc.), nursing, anaesthetics, physiotherapy, mental health and prosthetics to name but a few. The important roles that the families and friends of the injured play in their recovery is also highlighted in the book. They are involved in the new journey that the injured now face.

First-hand accounts from those injured in Afghanistan and those who worked to help them provide a very personal aspect to the book. These stories are also related back to similar ones from previous wars. Whilst the book highlights the pain and suffering endured during recent conflicts (and beyond), it also touches on the inspiring acts and innovative ideas that stemmed from the suffering and the need to try and reduce this. These ideas came from patients, families, medical and military personnel and researchers. Examples include ensuring the most efficient set up for treatment facilities in the Camp Bastion Hospital at one end of the continuum to creating spaces at Headley Court that facilitated the rehabilitation of individuals at the other end.

Many of those saved in Afghanistan are considered to be 'unexpected survivors' and the book considers what this means for those people during treatment, through rehabilitation and into the future. Dr Mayhew highlights that there are many unknowns for these unexpected survivors and the need for more research to better understand what this means. She introduces the work of the Centre for Blast Injury Studies and other research facilities which are working in this area.

The book received excellent reviews from publications such as The Sunday Times, The Literary Review and The Spectator magazine and provides an important insight for new members of the Centre to understand how their work fits into the need for greater understanding of blast injuries and those affected by it. The book highlights the wonderful work that has been done to date, but also reminds us

of the research imperative. We at CBIS are glad to be answering the call. The introduction to “A Heavy Reckoning” is compulsory reading for new starters at CBIS and we regularly encourage the Centre’s stakeholders to read this wonderful book. All who do gain a new insight into the world of the blast injured and those who are working to understand blast injury in more detail.

Staffing & Facilities

'Who' is the Centre for Blast Injury Studies?

In 2017, the Centre was made up of about 50 members from across Imperial College London, with expertise in science, engineering and medicine. Seven departments within the College are represented (Bioengineering, Dyson School of Design Engineering, Civil and Environmental Engineering, Medicine, National Heart & Lung Institute, Physics and Surgery & Cancer), highlighting the truly collaborative and multidisciplinary nature of our research. Additionally, many Centre members bring with them strong links to military medicine which continually feeds into the Centre's strategic direction.

Centre academics

We currently have 16 academics within the Centre who work across the different clinical priorities and who supervise PhD students and postdoctoral researchers.

Professor Anthony Bull (Bioengineering)
Centre Director

Professor (Col) Jon Clasper (Bioengineering)
Clinical Lead

Dr Spyros Masouros (Bioengineering)
Associate Centre Director

Professor Alison McGregor (Surgery & Cancer)
Associate Centre Director

Dr Robert Dickinson (Surgery & Cancer)

Dr Mazdak Ghajari (Dyson School of Design Engineering)

Dr Claire Higgins (Bioengineering)

Dr Angela Kedgley (Bioengineering)

Dr Andrei Kozlov (Bioengineering)

Dr Andrew Phillips (Civil and Environmental Engineering)

Dr Bill Proud (Physics)

Professor Sara Rankin (National Heart & Lung Institute)

Dr Tobias Reichenbach (Bioengineering)

Professor Andrew Rice (Surgery & Cancer)

Professor David Sharp (Medicine)

Professor Mark Wilson (Surgery & Cancer)

Management Group

The Centre Director, Clinical Lead, two Associate Directors and the Research Programmes Manager meet monthly to discuss operational management of the Centre and its strategic direction. Financial and scientific governance is also a key topic for the group. The Management Group works closely with The Royal British Legion and the Centre's Advisory Board.

Advisory Board

CBIS is extremely lucky to have such an experienced Advisory Board. Chaired by Admiral of the Fleet the Lord Boyce KG GCB OBE DL, the Board meets twice a year to provide oversight of the Centre and advice to the Management Group. Members of the Board have academic, clinical, defence and industry expertise and provide strong support and guidance in these areas with significant additional input provided outside the regular meetings.

The Royal British Legion

As the Funders of the Centre for Blast Injury Studies, The Royal British Legion have ultimate oversight of the work within the Centre. The Centre Director regularly meets with the Director General and the Director of Operations to discuss the running of the Centre, and other members of The Royal British Legion attend events at the Centre.

New Staff

This year saw three new post-doctoral research associates join the Centre as well as one PhD student move to a new post-doctoral position. Seven new PhD students have joined the Centre, with representation from two different departments and the Centre has also had a change-over and expansion of administrative staff. As with previous years, the Centre is thriving and continuing to grow.

Post-Doctoral Researchers Joining CBIS in 2017



Dr Cornelius Donat joined the Centre at the beginning of 2017 as a post-doctoral researcher working with Professor David Sharp and Dr Magdalena Sastre in the Department of Medicine. Cornelius' project is dedicated to increasing the understanding of the pathologies of primary and secondary/tertiary blast injuries in the brain by using animal models and defined biomechanical parameters. Through a multidisciplinary approach, he aims to establish a prediction of damage pattern and mechanical loading through a computational model. Ultimately, the group will test these predictions and biomechanical variables in appropriate animal models by employing translatable outcome measures, such as novel high-field MRI methods and validate the findings against advanced histology. Before joining the Centre, Cornelius undertook his PhD at the University of Leipzig/Helmholtz-Centre Dresden-Rossendorf, Germany, where he focused on identifying cholinergic changes following experimental Traumatic Brain Injury (TBI) in small and large animal models using molecular imaging methods. Following this, he remained at the Helmholtz-Centre Dresden-Rossendorf to carry out postdoctoral research on *in vitro* and *in vivo* evaluation of new radioligands for Positron-Emission-Tomography. Following that he moved to the Neurobiology Research Unit at Rigshospitalet, Copenhagen, Denmark, to research molecular imaging of nicotinic acetylcholine receptors in the rodent, porcine and human brain.

Dr Shabnam Kadir joined the Centre as a Research Associate in January 2017. Working with Dr Tobias Reichenbach, her project involves exploring the role of cortical oscillations in speech recognition in noisy environments. Although this project is in its preliminary stages, there is potential to apply for further grants for the development of devices to aid sufferers of Auditory Processing Disorder (APD), a condition often caused by blast injuries. Sufferers of APD have difficulties distinguishing between competing sounds despite being able to perform normally on standard hearing tests. Shabnam is conducting experiments involving electrical neurostimulation of the cortex to see if speech recognition can be enhanced and/or diminished, as well as building mathematical models to explain auditory processing of speech in noise. Prior to joining the Centre, Shabnam's specialty was in the field of string theory and algebraic geometry. She received her DPhil from the University of Oxford in 2004 for work entitled "The Arithmetic of Calabi-Yau manifolds and Mirror Symmetry" and undertook two post-doctoral fellowships, one at the University of Toronto and one at Leibniz Universitaet Hannover, Germany. In 2011, Shabnam changed fields and started working in the laboratory of Kenneth D. Harris. One of the projects she worked on involved extracting meaningful information from the increasingly large datasets obtained from recordings of neuronal activity in the brain, both *in vivo* (e.g. in behaving animals) and *ex vivo* (e.g. retinal explants).





Dr Darshan Shah started working in the Centre in November 2017. Before joining the Centre, Darshan completed his PhD in musculoskeletal biomechanics at Imperial College London, where he developed a wrist simulator which replicates the natural wrist motions on artificial or cadaveric hands. Using biomechanical concepts, he compared normal healthy human wrists to pathological and/or surgically treated wrists. Well-known to CBIS for many years through working on a related project during his MSc, he is now working within the Centre with Dr Angela Kedgley, pursuing research in upper limb rehabilitation. This work is primarily focused on the functional biomechanics of the upper limb following hand trauma and its association with those who have lower limb amputations. Alongside this, he also oversees the motion capture laboratories in the Department of Bioengineering which house many CBIS rehabilitation projects.

From PhD to Research Associate

This year, we have had one former PhD student decide to continue their career within the Centre. We are committed to developing the careers of Centre members and the opportunities for taking on more responsibility with the Centre and becoming blast injury experts are important.

David Sory joined the Centre as a PhD student in 2014 working with Dr William Proud and Professor Sara Rankin on a project entitled “Dynamic Loading of Periosteum-Derived Mesenchymal Stromal Cells”. The aims were two-fold. Firstly, David developed *in vitro* experimental platforms that were capable of mechanically-loading 3-D culture systems and demonstrated its use as a quantifiable, reproducible model of *in vitro* IED/blast mine trauma of extremities. Secondly, he investigated the stimulation of osteogenesis in periosteum-derived mesenchymal stromal cells (PO MSCs) in response to mechanical insults simulating IED/blast mine trauma. David completed his project at the end of 2017 and is awaiting his viva. He has now transitioned to a Research Assistant position within the Centre, working on a new project (again with Dr Proud and Professor Rankin). The project firstly aims to identify molecular and cellular changes in response to mechanical insults approaching blast injury conditions, and identify biomarker candidates associated with trauma-induced osteogenesis. Secondly, the project aims to investigate in the role of mechanotransduction concurrently to blast trauma in cells adherent to biofidelic extracellular matrix. Prior to David joining the Centre, he completed a Master of Science, Bioengineering degree at Liege University, Gembloux, Belgium (2009) and a Master of Engineering, Electro-mechanical Engineering at ECAM, Brussels, Belgium (2013).



New CBIS PhD students



Emily Ashworth completed a Bachelor of Nursing (Hons) degree at the University of Manchester (2011) before going on to complete an MRes Clinical Research in Design and Management at Imperial College London (2016). Emily’s MRes project looked at validating a patient generated outcomes measure in patients with claudication. Most recently Emily has worked as a senior trauma nurse at St. Mary’s Major Trauma Centre. Emily joined the Centre as a PhD student in October under the supervision of Professor Mark Wilson, Professor Anthony Bull and Lt Col Stuart Harrison. Her project is entitled “Searching for

Civilian Surrogates for Military Blast Traumatic Brain Injuries.” Brain injury is prevalent in military personnel who have been exposed to blast, however it is unknown what the pathophysiology of blast head injuries look like in relation to mechanism and whether these are comparable to head injuries seen in civilians who have been exposed to different mechanisms. Emily’s work looks to investigate this further. Emily also has military links as she is currently an Officer Cadet in the final stages of phase 1 training in the Royal Navy Reserves. She is also affiliated with the Academic Department of Military Nursing through her leadership of the London Acute, Trauma and Emergency Research Network (LAnTERN).

Kirstie Edwards joined the Centre at the end of September 2017, following her graduation from a MEng in Mechanical Engineering at Imperial College London. Her Masters project looked at changes in material properties of retrieved ceramic hip implants. Kirstie’s PhD project is supervised by Dr Syros Masouros and she is focussing on creating a combined finite element model of the foot and ankle with a novel orthosis (called the IDEO) designed to help patients who have suffered calcaneal injuries from underbody blasts. The aim is to understand the extent of offloading this orthosis provides and whether it can be further improved.

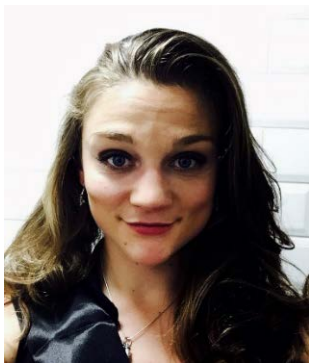

Hazel May joined the Centre at the end of September 2017, following completion of a Natural Sciences BSc (Hons) at the University of Bath. As part of this undergraduate degree, Hazel spent a year in industry, conducting translational neurotrauma research in the lab of Jonathan Lifshitz (Phoenix, Arizona). Her project focused on identifying biomarkers of synaptogenesis post-traumatic brain injury. Hazel’s PhD project at the Centre is entitled “Novel neuroprotective treatments and mechanisms of injury in blast traumatic brain injury” and is supervised by Dr Robert Dickinson, Professor David Sharp and Dr Mazdak Ghajari. The project aims to characterize a novel model of blast TBI that has been developed in the group, and to use the model to evaluate the potential of novel therapeutic interventions that could be given to blast TBI patients after injury to limit or prevent injury progression and the resulting neurocognitive impairments.

Martin Ramette graduated with a BSc in General Engineering from Ecole CentraleSupélec, Paris, France, in 2015. He also attained a double Degree program between the MSc Biomedical Engineering at Imperial College London and the MSc General Engineering at Ecole CentraleSupélec. His Master Thesis at Imperial College was entitled "Finite element modelling of the knee joint for fine Medial Collateral Ligament behaviour prediction". Martin’s PhD project, “Influence of the mechanical loading environment on the development of Heterotopic Ossification”, within the Centre is being supervised by Professor Anthony Bull. He is looking at 3D finite element modelling of ectopic bone formation in the stump of post-blast injury military amputees.



Biranavan Sivapuratharasu graduated with a Masters in Mechanical Engineering from Imperial College London in 2015. As part of this course he undertook an Undergraduate Research Opportunity Programme within the Centre, supervised by Dr Spyros Masouros in the summer of 2014 and completed his final year individual project in collaboration with the Centre. At the end of September 2017, Biranavan joined the Centre full time working on a project entitled “Understanding Spinal Loading in Amputees”. This project is supervised by Professor Alison McGregor and Professor Anthony Bull and aims to understand the aetiology and mechanics behind low back pain in traumatic amputees, to quantify spinal posture motion and loading during daily activities, and to extend the existing musculoskeletal models to include the lower back. This will lead on to developing recommendations on spinal health for amputees.



New Administrative Support



Dr Lucy Foss is the Research Programmes Manager within the Department of Bioengineering, with responsibility for managing the Centre and assisting in other trauma-related grant applications and projects. Lucy has taken over from Dr Emma Burke. Lucy provides operational oversight of the Centre, assisting with processes, events, finances and grant and report writing. A key part of managing the Centre is engaging with stakeholders within and outside Imperial, including The Royal British Legion and the Ministry of Defence amongst others. Lucy joins the Centre from over four years at the Wellcome Trust where she was a Grants Adviser in the Cellular, Molecular and Physiological Sciences Team, followed by the Team Manager for the Neuroscience and Mental Health Team; both within the Grants Management Division. Prior to joining the Wellcome Trust, Lucy completed a PhD at the University of Birmingham entitled “Effects of tetanus toxin on synaptic proteins in models of temporal lobe epilepsy”.

Amanda Wallace is the Centre’s new administrator, joining us at the end of October and taking over from Melanie Albright. In line with the ever growing needs of the Centre and its members, this post is now a full time position. Amanda joins the Centre from working at Hammersmith Hospital - Imperial College NHS Trust and before that studying a degree in Psychology with Criminology at Middlesex University. She brings experience of event management and secretarial and financial administration. Within the Centre Amanda provides support for organising events, coordinating meetings, and the administration of recruitment and finances. She also leads on promoting the Centre through social media and our online presence. Amanda is a key point of contact for Centre members.



PhDs awarded

We would like to congratulate the following people who successfully completed their PhDs and MD(Res)s this year! Some of these were funded by studentships from the Centre, others had separate funding but their work was closely associated.

Alexandros Christou (PhD) – *Modelling spinal injury due to high-rate axial loading* – supervised by Dr Spyros Masouros

Naomi Rosenberg (PhD) – *Investigating heterotopic bone behaviour through the development of a finite element model* – supervised by Professor Anthony Bull

Claire Webster (PhD) – *Mapping the blast pelvis* – supervised by Dr Spyros Masouros and Professor (Col) Jon Clasper

Dafydd Edwards (MD(Res)) – *An investigation into the outcome of amputations from recent military operations with regard to the formation of heterotopic ossification* – supervised by Professor Anthony Bull and Professor (Col) Jon Clasper.

Leavers

This year we have seen a number of Centre members move onto new positions. We would like to wish all of the people listed below well in their new roles and thank them for their valued input to the Centre over the years. We look forward to ongoing collaborations with them in the future.

Melanie Albright

Hari Arora

Spencer Barnes

Emma Burke

Alexandros Christou

Dafydd Edwards

Angelo Karunaratne

Claire Villette

Claire Webster

Appointments

2017 has seen a number of new appointments for CBIS members. Dr Hari Arora became a National Committee Member of the British Society for Strain Measurement (BSSM). Dr Spyros Masouros was promoted to Senior Lecturer within Imperial College London and was elected Member of the Combined Services Orthopaedic Society (CSOS). Professor David Sharp has this year been appointed Deputy Head (Clinical) for the Division of Brain Sciences within the College and also Head of the Centre for Restorative Neuroscience within the Division of Brain Sciences. In addition he is a Jacobsen Lecturer at the University of Newcastle, UK. Professor Sharp has joined the Scientific Advisory Board for the journal *Brain* and has become a member of the Rugby Football Union Independent Expert Concussion Panel.

Awards

Dr Hari Arora contributed towards the development of an online educational tool for new academics and PhD students across Imperial, which resulted in a national award to Imperial College London from The Guardian for Student Experience (March 2017).

Professor (Col) Jon Clasper was awarded a King James IV Professorship, from the Royal College of Surgeons of Edinburgh (September 2017). The award is in recognition of Professor Clasper's expertise in clinical blast research. As part of this award, Professor Clasper will give a lecture at a National meeting and write a publication, both in 2018.

Lt Col Dafydd Edwards was awarded the Alexander Medal by Prince Richard Duke of Gloucester, for his UK military amputee research (September 2017).

Captain David Henson was awarded a fellowship by the University of Hertfordshire for his contributions to sport and the local community.

Dr Andrew Phillips received the Imperial College London President's Award for Excellence in Supporting the Student Experience.

Professor Sara Rankin received the Imperial College London Leadership Award for Excellence in Societal Engagement.

Claire Villette received the Unwin Award for Best PhD thesis in the Department of Civil and Environmental Engineering.

Being a Researcher in CBIS

Dr Erica Di Federico – Postdoctoral Researcher



My career path is a reasonably straightforward one. I went to School in Rome and did my first degree at the University of Tor Vergata, studying for a BEng in Medical Engineering, followed by an MSc on the same subject. Working on my final year masters project is what made me realise that my long-term career would be in research; so I moved to London where I undertook my PhD in cell mechanobiology at Queen Mary University of London. This then led me to take up a post-doctoral research position in the Centre for Blast Injury Studies, a truly inspiring multidisciplinary environment where I get the chance to interact with lots of talented people.

My current research centres on understanding the structural organization and tissue mechanics of the ligament to bone insertion site across strain rates up to blast strain rates. This project is particularly interesting and quite challenging. Indeed to gain a deeper knowledge of the mechanisms by which load is transferred across the native tissue-to-tissue interfaces, the characterisation of its structural and mechanical properties is paramount. However, the heterogeneity and the modest size scale of the interface make the direct measurement of the mechanical properties at the ligament-to bone insertions a demanding task. In order to overcome this issue I use synchrotron small and wide angle X-ray diffraction combined with mechanical testing and mathematical modelling to critically describe the behaviour of this complex system.

Understanding of the insertion site biomechanics will enable us to identify the relationship between bone failure and ligament failure in traumatic amputation due to blast and support the development of computational models to analyse ligament failure and reconstruction.

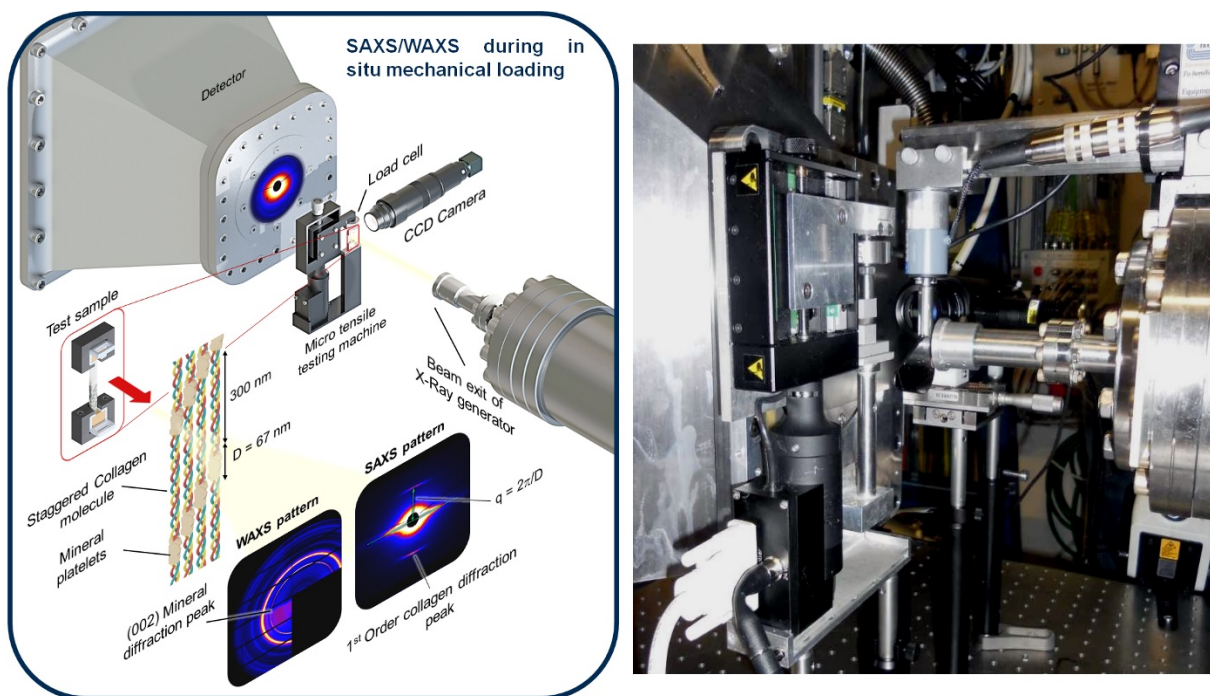

Figure 3: Experimental setup schematic of small and wide angle X-ray scattering (I22, Diamond Light Source, UK) during *in situ* mechanical testing of human ligament-to-bone insertion site.

Findings of my research would ultimately have an impact on the design of suitable scaffolds for insertion replacement and ultimately for the clinical translation of interface tissue engineering approaches to the functional and integrative repair of ligament injuries.

The best thing about my job is the diversity of tasks I might be presented with on a day to day basis. I particularly enjoy solving problems and when you finally get something to work, that you possibly have been occupied with for a while, it is really satisfying.

No one day is like another: usually though upon arriving in the office, I have a cup of coffee while I check my emails and then I do a quick search on the internet looking for new papers which might be relevant in my research area. Past that, the day can be very varied and depending on the progress of my research it may involve designing experiments, working in the lab, running a computer model, or writing papers and going to meetings with other researchers.

Research is a very rewarding profession and working in the right place makes it even better!

Xiancheng Yu – Year 2 PhD Student

My project is entitled “Improving helmet design to mitigate blast induced traumatic brain injury (TBI)”. Blast induced TBI has attracted increasing medical and scientific attention due to the large percentage of combat troops that sustain blast attacks. Helmets are the most essential equipment that protect the head and brain against ballistic and blast threats. However, the combat helmets are traditionally designed to prevent injuries caused by ballistic loadings, such as shrapnel, bullet-strike, fragments, etc. The present combat helmets cannot provide enough



protection against blast waves propagating from the explosions. In fact, combat helmets have been extensively tested for ballistic penetration resistance, but their performance on resisting and mitigating the blast waves is largely unknown. As blast wave propagation is an important factor that causes TBI, more effective helmet designs that can better reduce TBI are in urgent need.

The first challenge of my project is understanding the mechanisms of blast induced TBI, particularly the role of the primary pressure wave. Recent neuropathological analyses of brain tissue from animal tests and post-mortem cases of blast TBI show that the brain tissue close to ventricles sustains damage, in contrast to impact TBI. This indicates that the mechanism of blast induced TBI is quite different from impact induced TBI. Thus, how blast wave transmits through the brain tissue and how it develops tissue injury are the first questions to answer. The second challenge has been the development of protective materials and structures to mitigate blast wave. This is also the final goal of my PhD project. The blast wave mainly transfers through the helmet to the human head, which means helmet is the only equipment for blast wave mitigation. Thus, the task is obvious: designing the helmet

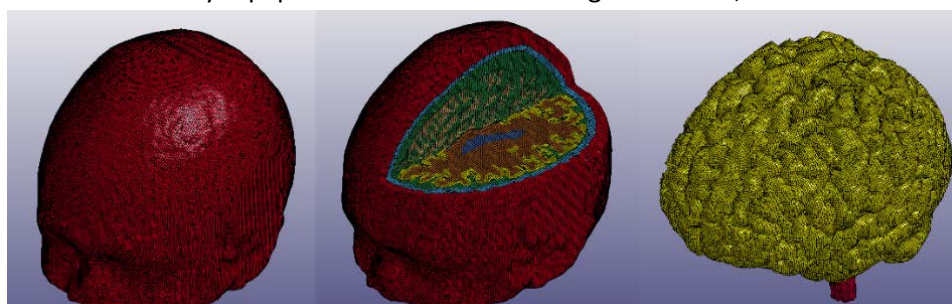

in a way that reduces the blast wave transmitted into the brain as well as the acceleration rate of the head.

There are some possible wave mitigation strategies. However, many strategies are only suitable for certain blast wave profiles, which means they are not efficient for every blast wave profile. Besides, for helmet design, many ergonomic factors need to be considered, including weight, weight distribution, air circulation and freedom of head movement. Thus, for example, blast mitigation strategies used on civil structures may not be suitable for helmets. My idea is to design multi-layer materials and structures to convert the blast wave to periodical shock wave in the materials, with a certain frequency. Then a visco-elastic material layer is proposed to attenuate the shock wave.

My daily work involves finite element analysis (FEA) and testing. Most of my time is spent on FEA to simulate head response under different blast conditions, as well as the blast mitigation performance of designed materials/structures. Mechanical testing is another important part of my PhD. Shock tube facilities are used to investigate blast wave transmission and test the performance of designed protective materials/structures.

Working in CBIS is really a fantastic experience. There are many helpful, lovely and knowledgeable colleagues ready to offer advice and help. Also, the strong support and high-grade facilities of the Centre maximize the potential of my PhD project.



Alumni

Lieutenant Colonel James Singleton

I was a full time doctoral candidate at CBIS from October 2011 until October 2013. My thesis was titled 'Blast-Mediated Traumatic Amputation: Underlying Mechanisms and Associated Injuries' and Colonel Jon Clasper and Professor Anthony Bull were my supervisors. I worked most closely with bioengineering and some shock physics collaboration.

My work looked to better understand exactly how traumatic amputations – the separation of a limb or limbs from a person's body following injury – are caused by the various physical forces generated by explosions. I was able to gain new insight into this area because of the recent adoption of post mortem CT scanning of service personnel killed in action in Afghanistan. This provided unparalleled levels of detail of these terrible injuries and enabled me to significantly advance our understanding of the injury mechanisms involved.

The following publications resulted from my research:

- **Singleton JAG**, Gibb IE, Bull AMJ, Mahoney PF, Clasper JC. *External explosions causing in-vehicle blast lung injury in fatalities: new insights from post mortem CT analysis*. J Trauma 75.2 (2013): S269-S274. PMID: 23883919
- **Singleton JAG**, Gibb IE, Hunt NCA, Bull AMJ, Clasper JC. *Identifying future 'unexpected' survivors: a retrospective cohort study of fatal injury patterns in victims of improvised explosive devices*. BMJ Open. 3.8 2013. PMID: 23906957
- **Singleton JAG**, Walker NM, Gibb IE, Bull AMJ, Clasper JC. *Case suitability for definitive through knee amputation following lower extremity blast trauma: analysis of 146 combat casualties, 2008–2010*. J Royal Army Med Corps (2013) jramc-2013. [online first] PMID 24351315
- **Singleton JAG**, Gibb IE, Bull AMJ, Clasper JC. *Blast-mediated traumatic amputation: evidence for a revised, multiple injury mechanism theory*. J Royal Army Med Corps (2014), jramc-2014. [online first] PMID: 24408908

I was awarded the following prizes for my research:

CSOS 2012 **Sir Philip Fulford memorial prize, best podium presentation**

Fred Heatley 2012 **Runner up, best podium presentation**

RAMC prizes 2013 **Montefiore memorial prize (best military surgical trainee)**

CSOS 2014 **Peter Templeton memorial prize, best trainee presentation**

(CSOS - Combined Services Orthopaedic Society, Fred Heatley – South London/Kent Surrey and Sussex Orthopaedic Registrar research prize meeting, RAMC - Royal Army Medical Corps)

The highlight to working at CBIS was the ethos: the synergy achieved through intra- and interdepartmental collaboration and consultation. The open door policy and accessibility of colleagues coupled with intellectual curiosity and willingness to work together or provide help or guidance made for a very happy and productive two years.

Since leaving CBIS I have completed my orthopaedic training and I recently promoted to Lieutenant Colonel and took up an orthopaedic consultant post at Frimley Park Hospital, specialising in trauma and knee surgery.

Education

The Centre puts a significant emphasis on education. This ranges from courses at Imperial College London for undergraduate and postgraduates to learn more about research, to courses for clinicians and those who work directly with blast injuries. Below are some examples of the programmes and projects that we have been involved in and run this year.

Undergraduate Research Opportunities Programme (UROP)

The UROP is an opportunity at Imperial College for students from within and outside the College to gain an appreciation of research and the environment in which it takes place. The Centre continues to support a number of students through the programme; helping undergraduate students learn important new skills, allowing young academics and researchers to learn about supervising students, and ultimately contributing important research to the Centre.

This year we saw four students spend ten weeks in the Centre, and below is an overview of their projects:

- Project 1: John Millwood Hargrave. This project stemmed from Dan Stinner and Phill Pearce being faculty for the Surgical Innovation module of the 2017 Surgery and Anaesthesia BSc. Their case studies examined the challenges of trauma research and emphasised the need for multidisciplinary research. John Millwood Hargrave, then a penultimate year medical student and member of the Army Reserves, was keen to join the Centre as part of the Undergraduate Research Opportunity Programme. His project, conducted over the summer of 2017 and supervised by Phill Pearce, was to investigate the epidemiology of paediatric blast injury in contemporary conflict. John's work has formed the basis for a larger body of work conducted within the Paediatric Blast Injury Partnership.
- Project 2: James Lee worked on a project called *Shock Tube Study of Blast Mitigation*. The project investigated the blast attenuating property of perforated-plate combinations using the shock tube facility. The main aim was to identify the spatial effect in the two-plate mitigating system over a large range of separation between the plates. This was an addition to the existing CBIS work on blast mitigating properties of various porous and granular materials. Supervised by Dr Thuy-Tien Nguyen.
- Project 3 was undertaken by Eve-Marie Stammler from Bio-Sciences Superior Institute of Paris (ISBS). The project involved image analysis of lung data acquired at Diamond Light Source and development of a finite element model to complement surrogate lung printing research that is ongoing within the Arora group. Supervised by Dr Hari Arora.
- Project 4 was undertaken by Lorna Barron from the Department of Bioengineering at Imperial College London. It looked at idealised finite element model development; exploring strategies for tessellation and development of multi-scale approaches to damage prediction in the lung. Supervised by Dr Hari Arora.

Undergraduate Projects

As well as UROPs, undergraduates can work on research relevant to the Centre as part of their undergraduate degree. Below is an overview of some of the recent projects.

- Projects 5 and 6: Professor Anthony Bull supervised two undergraduate Group Projects this year. The first was for seven third year students and was entitled 'Wearable functional

electrical stimulation for therapeutic use'. Another seven students worked on a Group Project called "Through knee prosthesis – shape optimisation for stability".

- Project 7: Dr Tobias Reichenbach supervised Amna Askari on a project entitled 'Modeling of the auditory brainstem response for an assessment of hidden hearing loss'. This project has developed a model of the auditory brainstem response in hidden hearing loss. The results feed into the CBIS-funded PhD project of Marina Saiz Alia on hidden hearing loss in the armed forces.
- Project 8: Chloe Jeremy – 'Bioinspired protection systems' – supervised by Dr William Proud. This short study looked at how animals, such as woodpeckers, have evolved to be impact resistant, in term of head, spine etc. In particular the shape of peregrine falcons has been used in train design (moving fast along rail tracks) as well as woodpeckers (trains entering tunnels).
- Project 9: Gareth Lomax – 'The crowd dynamics of panic' – supervised by Dr William Proud. On average 1000 people per year are killed due to crushing injuries in crowds. There is an assumed correlation between panic and crushing injuries. This research considered the use of mobile phone technology to monitor crowd movements and also perceived agitation levels. This type of information is useful in developing practical crowd models for use in studying resilience during extreme events such as terrorist attacks.

Masters Projects

A number of Masters (MSc) projects have been supervised and co-supervised by Centre members this year and additional details are provided below:

- Project 10: Adele Cherpin – 'Military heel fractures' – co-supervised by Professor Anthony Bull and Dr Daniel Stinner.
- Project 11: Kristina Agius – 'Whole body modelling of falls and bone fractures' – supervised by Professor Anthony Bull. Kristina has now gone on to a PhD elsewhere in Imperial College.
- Project 12: Nassib Shah – 'Ligament insertion biomechanics – effect of age and loading rate' – co-supervised by Professor Anthony Bull and Dr Erica Di Federico.
- Project 13: Chrissa Kaza – 'Neurostimulation for enhancing speech in noise comprehension' – supervised by Dr Tobias Reichenbach. The developed stimuli as well as the obtained pilot data fed into the work of CBIS-funded PDRA Shabnam Kadir.
- Project 14: Mikolaj Kegler – 'Decoding auditory attention in real time from brainstem responses to speech' – supervised by Tobias Reichenbach. The results will be important for CBIS-funded PhD student Octave Etard who works on electrophysiological assessments of central hearing impairments."
- Project 15: Jacques Feng – 'Sensors for prosthetic limbs' – supervised by Professor Alison McGregor and Dr William Proud.
- Project 16: Richard Eames and Matthew Dodd – 'Modelling of the human thorax under blast loading' – supervised by Dr Hari Arora and Dr William Proud.
- Project 17: Yiqi Zhu and Hasan Mohammed – 'The dissipative properties of granular materials' – supervised by Dr William Proud.
- Project 18: Chloe Cole and Stefano Galimberti – 'The response of a simple polymer structure under dynamic load' – supervised by Dr William Proud.
- Project 19: Julia Seidel – 'The hazardous and blast properties of starch' – supervised by Dr William Proud and Dr A Bernal (University of the Andes, Bogota).

Internships

This year saw Dr William Proud and colleagues supervise 3 Internships:

- Project 20: J Haller and A Jouffrey (National School of Mechanical Engineering, France) – ‘Blast injuries on the aorta (Study of mechanical properties of the aorta/viscoelastic materials)’ – supervised by Dr William Proud, David Sory and Danyal Magnus.
- Project 21: B Verdun and G Lacrosse (National School of Mechanical Engineering, France) – ‘Improved illumination for biological samples under SHPB loading’ – supervised by Dr William Proud and David Sory
- Project 22: M Felton (University of Saarland, Germany) – ‘The mechanical and mitigation properties of metal foams’ – supervised by Dr William Proud and David Sory.

Postgraduate Courses

Surgeon Commander Mansoor Khan, who works closely with members of the Centre, particularly through his involvement in the Trauma Bioengineering Network, leads the Trauma Management stream of the Surgical Innovation postgraduate course at Imperial College London. The Trauma Management stream is held at the St Mary’s Campus and covers all types of trauma. These include pre-hospital management, emergency room responsibility, intensive care management, rehabilitation and musculoskeletal trauma. The course makes use of simulation training and hands-on tissue dissection and ultimately gives trauma surgeons great insights into the overall management of trauma. Whilst the course is not formally linked to the Centre for Blast Injury Studies, it provides important skills to surgical trainees and those involved in multi-disciplinary teams who may encounter blast injuries as part of their jobs. The close working relationship between civilian and military clinicians with expertise in trauma medicine and the scientists and engineers at the Centre is quite unique and an important aspect of the Centre’s success.

Communication of the Work

Media Mentions

Royal British Legion article about Dr Reichenbach's research on hearing impairment in veterans. (<https://www.britishlegion.org.uk/community/stories/support/helping-veterans-suffering-with-hearing-problems/>). March 2017.

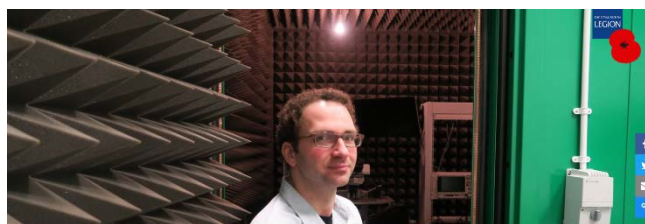

Imperial College London article entitled "3D model of American football player's brain reconstructs moment of impact". Work from Dr Mazdak Ghajari and Professor David Sharp that links closely with exploring the effects of blasts on brain tissue. (http://www3.imperial.ac.uk/newsandeventspggrp/imperialcollege/newssummary/news_28-4-2017-14-25-54). April 2017.

Medical Xpress article on computational prediction of chronic traumatic encephalopathy (CTE) pathology, relevant to repetitive impacts and blast exposure. This was the outcome of an Imperial Fellowship and the application was supported by CBIS. (<https://medicalxpress.com/news/2017-05-d-american-football-player-brain.html>). May 2017.

Imperial College London article "Imperial celebrates student success at Postgraduate Graduation Ceremonies 2017". Captain David Henson, the veterans' representative on the Centre for Blast Injury Studies' Advisory Board was recognised for Student Excellence at the Ceremony. (http://www3.imperial.ac.uk/newsandeventspggrp/imperialcollege/newssummary/news_2-5-2017-18-19-40). May 2017.

Soldier Magazine, a review of "A Heavy Reckoning: War, Medicine and Survival in Afghanistan and Beyond" by Dr Emily Mayhew. (www.soldiermagazine.co.uk). June 2017.

Birmingham Live article on "Spy autopsy expert will assist pub bombs inquest" showing that Professor Anthony Bull from the Centre will also be involved in the inquest into the Birmingham Pub Bombings from 1974. (<https://www.birminghammail.co.uk/news/midlands-news/spy-autopsy-expert-assist-pub-13171507>) June 2017.

Times Higher Education article "A Heavy Reckoning: War, Medicine and Survival in Afghanistan and Beyond, by Dr Emily Mayhew". The book is chosen as book of the week and the article discusses the book and its author. (<https://www.timeshighereducation.com/books/review-a-heavy-reckoning-emily-mayhew-profile-books-welcome-collection>) June 2017.



Literary Review write an article called "Cheating Death" about Dr Emily Mayhew's book A Heavy Reckoning: War, Medicine and Survival in Afghanistan and Beyond. (<https://reader.exacteditions.com/issues/58938/page/45>) July 2017.

Physics of Hearing program, Daily Nexus, University of California at Santa Barbara (UCSB), U.S.A. From the Reichenbach group. (<http://dailynexus.com/2017-08-24/hearing-a-biophysical-and-neurological-enigma/>). July 2017.

Biomedical Picture of the Day. This a picture of the forces predicted on brains of American football players when their heads collide forcefully together. The image is from Professor David Sharp and Dr Mazdak Ghajari's detailed computational model, which they are using for CBIS projects, amongst others. (<http://bpod.mrc.ac.uk/archive/2017/7/1>). July 2017.

Imperial College London publish a piece about Centre researchers leading on a project funded by the UK's Department of Health. "Imperial to help develop blast injury hub for conflict survivors in Sri Lanka". (http://www3.imperial.ac.uk/newsandeventspggrp/imperialcollege/newssummary/news_17-7-2017-14-44-28). July 2017.

World Para Athletics article "Prince Harry calls for London 2017 support" featuring Captain Dave Henson, our veterans' representative on the Advisory Board. (<https://www.paralympic.org/news/prince-harry-calls-london-2017-support>). July 2017.

Imperial College London article "Imperial College and Norwegian security researchers team up for secure societies". Dr Bill Proud provided members of Forsvarets Forskningsinstitutt (FFI), the Norwegian Defence Research Establishment, with a tour of the laboratories within the Centre for Blast Injury Studies. (http://www3.imperial.ac.uk/newsandeventspggrp/imperialcollege/centres/securityinstitute/newssummary/news_14-8-2017-12-9-34). August 2017.

BBC radio podcast focusing on publication from the Reichenbach group in eLife. (<https://www.thenakedscientists.com/podcasts/short/how-pick-out-voice-crowd>). October 2017

Article in The Engineer discussing the eLife publication from the Reichenbach group. (<https://www.theengineer.co.uk/neurons-speech/>). October 2017.

"A Heavy Reckoning: War, Medicine and Survival in Afghanistan and Beyond" is chosen as Solider Magazine book of 2017 after being picked as book of the month in June. (<http://viewer.zmags.com/publication/7213822c#/7213822c/66>). December 2017.

Public Engagement

Engaging the public in the Centre's research is very important and is achieved through a number of different routes. It includes people visiting the Centre to see the facilities and the work that goes on here, as well as Centre members going out to talk to the public at different events. Two of the main events during the year are the Imperial Festival and the Annual Networking and Research Update event (more information below), but our Centre members have also been part of a number of other exciting opportunities where they have promoted the work of the Centre:

Professor Alison McGregor has given talks at the Royal British Legion legacy day (September) and to the Royal British Legion Chelsea & Kensington Branch (November). Dr Emily Mayhew has done extensive public engagement work to support both the publication of her book ("A Heavy Reckoning: War, Medicine and Survival in Afghanistan and Beyond") and the Centre, particularly by describing its work in a historical context. This year, among others, she spoke at the National Army Museum, the Science Museum, the Old Vic theatre and at the Wellcome Collection. She appeared on Radio 4's Today programme alongside author Harry Parker, the Bath Literary Festival, and the Oxford Science Festival (also with Harry Parker). She is the first non-military medic to have given The Glover Lecture at RMA Sandhurst and the first historian to address The London Skin Club. Dr Mayhew was a judge on the creative writing panel for The Science Challenge and she teaches regularly on The Prince's Teaching Initiative. She was the historical consultant on the feature film "Goodbye Christopher Robin."

Imperial Festival & Alumni Weekend May 2017

The first weekend of May marked the College's sixth annual Imperial Festival. The Festival is a two day celebration of the College's achievements and activities. It is free to attend and attracted approximately 20,000 people across the weekend. At the Centre's stand entitled "Blast injury: the road to recovery", a mini rehabilitation centre was



created so that the public could learn about the recovery process after blast injury, at the same time as learning about the work of the Centre.

Visitors of all ages were able to become the "physio" or the "patient" and were taken through a series of exercises. As the patient, children were taken through a series of increasingly difficult balance exercises: single leg, wobble board, kneeling on exercise balls. They would be asked to carry out small tasks while balancing: spreading arms, touching their nose, closing eyes, catching juggling balls. All with the support of the parallel bars and a "physio". Then children had the chance to place one knee in a homemade model prosthetic and try walking with the support of the parallel bars (although, the two homemade prosthetics fell apart after the first day!) which was very challenging! The idea was to take them through an example amputee rehabilitation process and importantly, to highlight how physically and mentally demanding simple tasks can become when balance becomes an issue (as it is for amputees who are forced to 'relearn' balance using their core muscles rather than lower body).

After participating in the different exercises, members of the public were able to look at some real prosthetic legs and sockets, including the running blades that Dave Henson uses (these were very popular). To bring the whole stand together, posters showing current work from the Centre were also

on display, as well as a table devoted to smart sensors (work which CBIS member Matt Hopkins is working on). Finally there was also a demonstration of the presence of blast waves and the subsequent damage that can be caused by “invisible waves” using a homemade air cannon. All of the activities were there to help inform the public about blast injuries and the different specialist exercises that take place during rehabilitation; particularly why these exercises are necessary for good prosthetic fit and function.

The stand was incredibly popular from the start of the first day to the very end of the second day – even while other stands were packing away! On behalf of the Centre, many thanks to all of the volunteers for your part in engaging the public in the Centre’s work by way of the Festival. The Centre’s stand was a great success.



Figure 4: Imperial Festival

Left: member of the public trying to balance on a wobble board – this showing the importance of balance and how difficult it is, even without an injury such as an amputation.

Right: member of the public with a model prosthetic attached to a bent knee and trying to walk along with the aid of parallel bars.

Annual Network & Research Update Event November 2017

The objective of this years' meeting was to display cutting edge science across the continuum of trauma care from point of injury to rehabilitation. A major cross-cutting theme of the event was UK/US collaboration for military trauma research. As such, a large contingent of US clinicians and scientists, both military and civilian attended, making this a truly international event. For the first time, the event included an open call for scientific abstracts. Over 50 high quality abstracts were accepted for either poster or oral presentations. Additionally, a closed pre-meeting was held the day before the main meeting for a number of invited attendees to discuss specific areas of mutual interest.



The main day saw over 200 people attend, making it the largest to date. Attendees enjoyed three themed sessions; 1) Injury prevention and pre-hospital care, 2) In-hospital and acute care, and 3) Rehabilitation and long-term outcomes. These consisted of a mix of long (12 minute) and short (4 minute) talks providing an overview of the breadth of research within these areas, mostly within the UK and the US. We were also very pleased to welcome Major General Barbara Holcomb, Commanding General of the US Army Medical Research & Materiel Command to the event and she provided a very exciting Keynote Address. This focused on current and future challenges faced by deployed and domestic military medical systems and the importance of ongoing UK/US collaboration. Breaks between the sessions gave attendees an opportunity to network with others and discuss poster presentations and possible future collaborations.

Session 1, moderated by COL Jim Czarnik and Prof Mark Wilson included invited talks from Lt Col Chris Wright and COL Kirby Gross on the key challenges of the pre-hospital environment, while Surg Cdr Mansoor Khan discussed the role of physiological sensors. Short paper presentations included work on haemorrhagic shock, blast related hearing loss, and underbody blast injury.



Session 2 was chaired by COL Mike Davis and Lt Col Graham Lawton with invited speakers Prof Karim Brohi and Dr Todd McKinley discussing precision approaches to the trauma patient, and SqN Ldr Phill Pearce discussing quantification of blast injury. Short paper presentations included studies of vascular imaging, orthopaedic fixation methods, and neuroma formation.

Session 3 was moderated by Prof Alison McGregor and COL Anthony Johnson. This included invited talks from Dr Jason Wilken, Maj Pete Le Feuvre and LTC Kyle Potter on advances in amputation surgery and rehabilitation. Short paper presentations were also given discussing amputation, novel rehabilitative strategies, and advanced tissue engineering.

The event concluded with the awarding of best short paper prizes (to Major Max Marsden, RAMC and LCDR Scott Tintel, USN) and closing remarks from Prof Anthony Bull, before the networking amongst attendees continued.

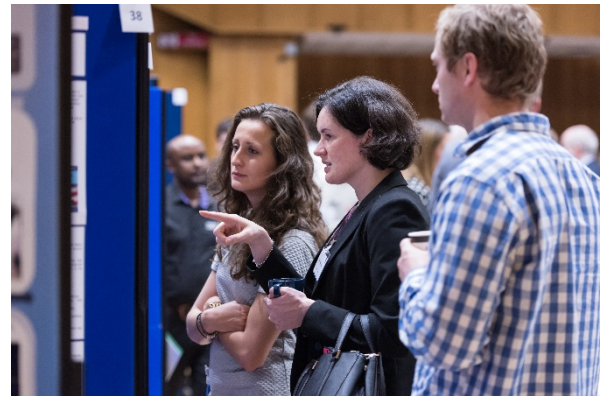

MAJ Stinner and Sqn Ldr Pearce led the organising committee for this event and we owe a debt of gratitude to them, Melanie Albright and Kemi Aofolaju for pulling together this fantastic event.

Publications

Below is a list of publications that have arisen from the work within the Centre. Journal publications are important platforms for disseminating research findings.

Arora H, Nila A, Vitharana K, Sherwood J, Nguyen T, Karunaratne A, Mohammed I, Bodey A, Hellyer P, Overby D, Schroter R, Hollis D (2017). Microstructural Consequences of Blast Lung Injury Characterized with Digital Volume Correlation. *Frontiers in Materials*, 4.

Breeze J, Fryer R, Pope D, Clasper J (2017). Injury representation against ballistic threats using three novel numerical models. *Journal of the Royal Army Medical Corps*, 163(3):193-198.

Campos-Pires R, Koziakova M, Yonis A, Pau A, Macdonald W, Harris K, Edge CJ, Franks NP, Mahoney PF, Dickinson RU (2017). Xenon protects against blast-induced traumatic brain injury in an in vitro model. *Journal of Neurotrauma*, online ahead of print.

Cheong VS, Karunaratne A, Amis AA, Bull AMJ (2017). Strain rate dependency of fractures of immature bone. *Journal of the Mechanical Behaviour of Biomedical Materials*, 66: 68-76.

Clasper J, Edwards D (2017). Blast Injury Mechanisms. *Explosives Engineering: Official Journal of the Institute of Explosives Engineers*: 18-21.

Grigoriadis G, Newell N, Carpanen D, Christou A, Bull AMJ, Masouros SD (2017). Material properties of the heel fat pad across strain rates. *Journal of the Mechanical Behaviour of Biomedical Materials*, 65: 398-407.

Logan N, Arora H, Higgins C (2017). Evaluating Primary Blast Effects *In Vitro*. *Journal of Visualized Experiments*, 127.

Newell N, Grigoriadis G, Christou A, Carpanen D, Masouros SD (2017). Material properties of bovine intervertebral discs across strain rates. *Journal of the Mechanical Behavior of Biomedical Materials*, 65: 824-830.

Newell N, Little JP, Christou A, Adams MA, Adam CJ, Masouros SD (2017). Biomechanics of the human intervertebral disc: A review of testing techniques and results. *Journal of the Mechanical Behavior of Biomedical Materials*, 69: 420-434.

Pearce PA, Bull AMJ, Clasper JC (2017). Mediastinal injury is the strongest predictor of mortality in mounted blast amongst UK deployed forces. *Injury*, 48(9): 1900-1905.

Rolfe E, Kelly M, Arora H, Hooper P, Dear J (2017). Failure analysis using X-ray computed tomography of composite sandwich panels subjected to full-scale blast loading. *Composites Part B: Engineering*, 129: 26-40.

Stinner DJ, Edwards D (2017). Surgical Management of Musculoskeletal Trauma. *Surgical Clinics of North America*, 97(5): 1119-1131.

Villette CC, Phillips ATM (2017). Microscale poroelastic metamodel for efficient mesoscale bone remodelling simulations. *Biomechanics and Modeling in Mechanobiology*, 16(6): 2077-2091.

As well as the list of publications above, there are many other relevant publications which are produced by Centre members. The above list has been kept to only those which are of direct relevance and funded by the Centre for Blast Injury Studies.

Books

Arora H, Rolfe E, Kelly M, Dear JP (2017). *Full-scale air & underwater blast loading of composite sandwich panels*: Chapter 7 in *Explosive Blast Response of Naval Composite Materials*. Mouritz A, Rajapakse Y (eds), Woodhead Publishing, Elsevier.

Barnett-Vanes A and Allen R. (2017) *How to Complete a PhD in the Medical and Clinical Sciences*. Wiley-Blackwell.

Grigoriadis G, Masouros SD, Ramasamy A, Bull AMJ (2017). *The lower extremities: computational modelling attempts to predict injury*: Chapter 16 in *Military Injury Biomechanics, the cause and prevention of impact injuries*. Franklyn M, Lee P V S (eds), CRC Press.

Mayhew E (2017). *A Heavy Reckoning: War, Medicine and Survival in Afghanistan and Beyond*. London: Profile Books Ltd and Wellcome Collection.

Proud WG (2017), *The ignition and Detonation of Explosives*. Contributed to the Chapter in the New Edition of the 'Services Textbook of Explosives'.

Rolfe E, Kelly M, Arora H, Dear JP (2017), *Composite Materials for Blast Applications*. Chapter 9 in *Dynamic Response and Failure of Composite Materials*. Lopresto V, Langella A, Abrate S (eds), Woodhead Publishing, Elsevier.

Sharp DJ, Fleminger S, Powell J (2016). *Traumatic Brain Injury*. Chapter 39 in *Oxford Textbook of Cognitive Neurology and Dementia*. Husain M, Schott JM (eds), Oxford University Press.

Invited Talks

Bull AMJ. Plenary keynote: *Disciplinary boundaries blasted away for clinical benefit*. Association of Trauma and Military Surgery, Plymouth, UK. 2017.

Bull AMJ. Named lecture: *Bioengineering is a blast: a journey from mechanics to healthcare*. Biomedical Engineering Association Prestige Lecture (at the IMechE). June 2017.

Clasper C: *Understanding Bomb Projectiles and Blast Injury*. British Orthopaedic Association Annual Congress, Liverpool, UK. September 2017

Clasper C. *Test Methodology: Car Crashes are not the same as under-vehicle explosions*. Human Response to Vibration, Cranfield, UK. September 2017.

Masouros S. *The Centre for Blast Injury Studies*. Tri-service radiology conference. Gosport, UK. November 2017.

Phillips ATM. *Computational Modeling of Pelvic Fracture*. European Federation of National Associations of Orthopaedics and Traumatology (EFORT). Vienna, Austria. June 2017.

Proud WG. *Mechanical Properties of Polymer-Bonded Explosive Systems*. TTC Conference. March 2017.

Proud WG. *Future Weapons*. Plenary at the Defence and Security Equipment International Conference, Edexcel, London. September 2017.

Reichenbach T. Hearing and Balance Centre Seminar, University of Southampton. January 2017.

Reichenbach T. Seminar, Ear Institute, University College London, UK. January 2017.

Reichenbach T. SIAM Conference on Applications of Dynamical Systems (DS17), Snowbird, Utah, USA. May 2017.

Reichenbach T. IERASG Biennial Symposium, Warsaw, Poland. May 2017.

Reichenbach T. Annual World Congress of NeuroTalk, Barcelona, Spain. May 2017.

Reichenbach T. KITP program Physics of Hearing, Santa Barbara, USA. June 2017.

Reichenbach T. Imperial Summer School on Robotics, Imperial College, U.K. September 2017.

Reichenbach T. SFB Cellular Mechanisms of Sensory Processing, Göttingen, Germany. September 2017.

Reichenbach T. Max Planck Institute for Dynamics and Self-Organization, Göttingen, Germany. September 2017.

Reichenbach T. CBIS Network Event, Imperial College London, UK. November 2017.

Reichenbach T. Central Auditory Group, University College London, UK. November 2017.

Reichenbach T. Royal Society Meeting, Chicheley Hall, UK. December 2017.

Sharp DJ. British Neuropsychiatry Association Annual Meeting. London. February 2017.

Sharp DJ. Royal Society of Medicine & Medico-Legal Society: Mild traumatic brain injury: Diagnostic, clinical and legal controversies. London. March 2017.

Sharp DJ. Keynote Lecture, Frontiers in TBI, London. July 2017.

Sharp DJ. Plenary Lecture, World Congress of Neurology, Kyoto, Japan. September, 2017.

Sharp DJ. Symposium organiser and lecturer, World Congress of Neurology, Kyoto, Japan. September, 2017.

Webster C. *The blast pelvis*. Tri-service radiology conference. Gosport, UK. November 2017.

Conference Presentations and Involvement in Subject Specific Meetings

8th Annual Conference of the Canadian Institute for Military & Veteran Health. Regina, Canada. September 2017.

McGregor AH, Hopkins M, Vaidyanathan R, *First Steps in Understanding the Long-term Health of Amputees*. Oral presentation.

14th U.S. National Congress on Computational Mechanics. Montreal, Canada. July 2017.

Grigoriadis G, Carpanen D, Bull AMJ, Masouros SD, *Foot and ankle injuries in under-vehicle explosions: a finite element study*.

20th Biennial Conference of the APS Topical Group on Shock Compression of Condensed Matter. St. Louis, USA. July 2017.

Each of the below have also been published in the Bulletin of the American Physical Society; 62(9).

Brown K, Butler BJ, Nguyen TN, Sory D, Williams A, Proud WG, *New Platforms for Characterization of Biological Material Failure and Resilience Properties*.

Magnus D, Proud W, Haller A, Jouffroy A, *Tensile characterisation of the aorta across quasi-static to blast loading strain rates*.

Magnus D, Smith L, Proud W, *Multiple wave compression of poly-disperse granular materials using the Split-Hopkinson Pressure Bar*.

Nguyen TTN, Masouros SD, Tear GR, Proud WG, *Investigation of Ballistic Penetration through Tibia Soft Tissue Simulant*.

Proud W, *The Response of Simple Polymer Structures Under Dynamic Loading*.

Sory DR, Amin HD, Rankin SM, Proud WG, *Osteogenic differentiation of periosteum-derived stromal cells in blast-associated traumatic loading*.

40th Annual MidWinter Meeting of the Association for Research in Otolaryngology. Baltimore, USA. February 2017.

Forte A, Etard O and Reichenbach T, *Complex Auditory-brainstem Response to the Fundamental Frequency of Continuous Natural Speech*.

Association of Trauma & Military Surgery Conference. Plymouth, UK. November 2017.

Bull AMJ, *Disciplinary boundaries blasted away for clinical benefit*.

Pearce AP, *Development of an in vivo model of underbody blast*.

Ballistics & Blast Wound Workshop. NFC Leeds, UK. October 2017.

Attended by Dr Spyros Masouros.

Blast, Impact and Dynamic Characterisation of Biological Materials session at the MACH 2018 Conference. Annapolis, USA. April 2017.

Session organised by Dr William Proud.

British Society for Strain Measurement (BSSM) Postgraduate Experimental Mechanics Conference. London, UK. November 2017.

This meeting was chaired by Dr Hari Arora and hosted by the Bioengineering Department at Imperial College London.

British Society of Audiology Basic Auditory Science Meeting. Nottingham, UK. September 2017.

Etard O and Reichenbach T, *EEG-measure correlates of intelligibility in speech-in-noise listening*. Poster.

Clinical Aspects of Blast. RCDM/ICRC Meeting. Cranfield, UK. September 2017.

This meeting was attended by Professor (Col) Jon Clasper.

Colt Foundation Annual Research Meeting. Royal Society of Medicine. London, UK. December 2017.

Pearce AP, Bull AMJ, Clasper JC. *Development of an in vivo model of underbody blast*.

Webster C, Gibb I, Clasper JC, Masouros S. *The blast pelvis*.

[Combined Service Orthopaedic Society conference. Edinburgh, UK. May 2017.](#)

McMenemy L, Williamson B, Ramasamy A and Kendrew J, *Titanium soldiers? A systematic review of Osseointegrated implants following lower limb amputation.*

[Extremity War Injuries XII: Homeland Defense as a Translation of War Lessons Learner. Washington, DC, United States of America. January 2017.](#)

Dr Daniel Stinner was the Symposium Co-Chair.

Stinner D, *Overview of EWI XII.*

Pearce PA, *Injury Associations within the Underbody Blast Environment.*

[Frontiers in TBI meeting. London, UK. July 2017.](#)

Professor David Sharp's group organised this inaugural meeting.

Campos-Pires R, Armstrong S, Sebastiani A, Luh C, Gruss M, Radyushkin K, Hirnet T, Werner C, Engelhard K, Franks NP, Thal SC and Dickinson R, *Xenon provides short term & long term neuroprotection in a rodent model of traumatic brain injury.* Poster.

Donat C and Sastre M, *Imaging and histological correlates in the Controlled Cortical Impact model.*

Ghajari M, *Computational biomechanics of traumatic brain injury: how can it help?*

Harris K, Armstrong SP, Campos-Pires R, Kiru L, Franks NP and Dickinson R, *Neuroprotection against traumatic brain injury by xenon, but not argon, is mediated by inhibition at the n-methyl-d-aspartate receptor glycine site.* Poster.

[GESELLSCHAFT für ANGEWANDTE MATHEMATIK und MECHANIK \(GAMM\), 88th Annual Meeting. Weimar, Germany. March 2017.](#)

Jung A, Luksch J, Felten M, Reis M, Sory D, Pullen AD, Proud WG, Larcher M, Valsamos G, Solomos G, *Investigation of strain-rate effects in Al foams and Ni/Al hybrid foams on different scales.*

[Heterotopic Ossification Symposium. Birmingham, UK. February 2017.](#)

Attended by Dr Claire Higgins.

[International Council for Biomechanics of Injury \(IRCOBI\) Council Meeting. Copenhagen, Denmark \(January 2017\) and Antwerp, Belgium \(September 2017\).](#)

Attended by Dr Spyros Masouros, Council Member.

[International Research Council on the Biomechanics of Injury Conference \(IRCOBI\). Antwerp, Belgium. September 2017.](#)

Christou A, Grigoriadis G, Carpanen D, Newell N, Masouros SD, *Biomechanics of a lumbar functional unit using the finite element method.*

Newell N, Carpanen D, Christou A, Grigoriadis G, Little P, Masouros SD, *Strain Rate Dependence of Internal Pressure and External Bulge in Human Intervertebral Discs during Axial Compression.*

Ghajari M, Hellyer P, Sharp D, *Predicting the Location of Chronic Traumatic Encephalopathy Pathology.*

Grigoriadis G, Carpanen D, Webster C, Newell N, Masouros SD, *The effect of the posture of the lower limb in anti-vehicular explosions.*

[International Society Biomechanics. Brisbane, Australia. July 2017](#)

Hopkins M, Vaidyanathan R and McGregor A, *Development of a Flexible Low Cost Pressure Sensor for Lower Limb Prosthetic Applications.* Oral presentation.

Zaharie DT, Phillips ATM, *Pelvic construct prediction of trabecular and cortical structural architecture.*

Villette CC, Phillips ATM, *Rate and age-dependent elasto-plastic bone material formulation for efficient fracture simulations.*

Villette CC, Castilho M, Phillips ATM, *Computational optimisation of heterogeneous bone tissue engineering scaffolds: and integrated design workflow.*

Japan-US Forum on Blast Injury (JUFBI). Tokyo, Japan. April 2017.

Clasper J, *Traumatic Amputation and Pelvic Injury Following Blast.*

Clasper J, *Pattern of Injury Following Under-body Blast.*

Meeting between Imperial College London and delegates from DSTL about improving design of combat helmets. London, UK. March 2017.

Organised by Professor David Sharp and Dr Mazdak Ghajari.

NATO HFM 271 1st meeting, Stockholm, Sweden (June 2017) and 2nd meeting, Quebec, Canada (October 2017)

Attended by Dr Spyros Masouros

"Physics of Hearing: From Neurobiology to Information Theory and Back", a two-month summer school at the Kavli Institute for Theoretical Physics (KITP). University of California Santa Barbara (UCSB), U.S.A. June 2017.

Dr Tobias Reichenbach was the lead organizer.

Real-world assessment of hearing aids and listening behaviour. London, UK. October 2017.

Etard O and Reichenbach T, *EEG-measure correlates of comprehension in speech-in-noise listening.*

Forte AE, Etard O and Reichenbach T, *Complex auditory-brainstem response to the fundamental frequency of continuous natural speech.*

"Speech Processing and Neuromodulation" colloquium. London, UK. November 2017.

Organized by Dr Tobias Reichenbach.

The Technical Collaboration Programme Conference. UK. March 2017.

Proud WG, *Mechanical Properties of Polymer Bonded Explosive Systems.*

The Mach Conference. Annapolis. Maryland, USA. April 2017.

Nguyen TN, Wilgeroth J, Brown KA, Proud WG, *Methods to re-create loading scenarios for blast injury studies with the shock tube system.*

Sory D, Amin H, Rankin S, Proud WG, *Osteogenic differentiation of periosteum-derived stromal cells in strain rate dependent traumatic loading.*

'The Physics of Injury Patterns from Explosive Devices' – section within the MSc Trauma Course at St Thomas's Hospital. London, UK. June 2017.

Section given by Dr William Proud.

The British Society for Strain Measurement 12th International Conference on Advances in Experimental Mechanics. Sheffield, UK. August 2017.

Arora H and Vitharana K, *Microstructural effects of blast on lung injury.*

Exemplar Research Findings

This year's CBIS publications cut across the breadth of clinical priorities and research methods used across the Centre. All our research is clinically-led and some of our key papers this year have opened up new important research questions for the Centre. For example, Phill Pearce's paper on mediastinal injury in mounted blast has significantly influenced our research strategy. His work showed that current trauma scoring methods have little fidelity for describing survivability in the blast environment and so we need to focus on creating new- or modifying current- scoring systems that will assist in diagnosis, treatment, and decision-making regarding protection and mitigation. He found that torso injuries, including those to the heart and great vessels, are the strongest indicators of mortality in under body blast and so we need to now understand this mechanism of injury to then propose mitigation. We are actively engaged in this follow on work.

We continue to advance our knowledge of the properties of materials to create fidelic computational models that we can use as design tools for mitigation technologies. As our clinical work has emphasised the importance of spinal loading in blast, so we have published work on the material properties of intervertebral discs, recognising that further work on high-strain rate properties of these is required. Material properties on their own are valuable, yet we should also focus on the complex loading environment that tissues experience during blast so that we can create a mapping between the injuries observed and the loading experienced. This forensic approach is used in all our work and we have published this year on a new experimental setup that recreates in a consistent way the complex loading experienced by bone, enabling mapping to injury mechanism. As the clinical work has highlighted torso injury, so we have started work on the major vessels within the torso and have published work on material properties of the aorta.

We are particularly excited this year to publish for the first time a potential therapy for blast-induced traumatic brain injury. This work by Dr Robert Dickinson and his team has been years in the making: first having to produce an experimental animal model of blast induced TBI (bTBI), and then testing xenon as a neuroprotectant. His group has produced the very first demonstration of xenon neuroprotection in blast injury and shows that xenon may be a potential first line treatment for bTBI.

Within CBIS we focus not only on improving immediate medical treatment and rehabilitation, but, in some cases it is clear that the only way to improve outcome is to reduce the injury at the point of blast loading through protection. Our work in this domain continues and so this has resulted in testing protective materials and structures, such as polymer structures, including polymer sandwich panels. This fundamental work feeds into the design of protection.

The long-term effects of blast injury for amputees has become a major focus for CBIS as we focus on the legacy of Iraq and Afghanistan. The coming years will see a growth in the outputs in this area and we are delighted to highlight the work by Dr Andrew Phillips' team in which his published metamodel for bone adaptation is now being used to study the very important clinical priority which is the known reduction in bone strength in above-knee amputees and the resulting risk of debilitating fragility fractures. His work will provide input into rehabilitation treatments for above-knee amputees and this work is now being established through his collaboration with Prof Alison McGregor, who leads in rehabilitation work in the Centre.

This brief description doesn't do justice to all the excellent work in the Centre and the research descriptions on the following pages will put some more meat on the bones. Research can sometimes take a long time, yet the productivity of the Centre's researchers is testimony to their excellence, drive, determination, and demonstrates how the Centre's structures support excellent research across many different important domains.

Microstructural Consequences of Blast Lung Injury Characterized with Digital Volume Correlation

Arora H, Nila A, Vitharana K, Sherwood J, Nguyen T, Karunaratne A, Mohammed I, Bodey A, Hellyer P, Overby D, Schroter R & Hollis D, (2017)
Frontiers in Materials, 4(41): 1-12

This study focused on microstructural changes that occur within the mammalian lung when subject to blast and how these changes influence strain distributions within the tissue. Shock tube experiments were performed to generate the blast injured specimens. Blast overpressures of 100 and 180 kPa were studied. Synchrotron tomography imaging was used to capture volumetric image data of lungs. Specimens were ventilated using a custom-built system to study multiple inflation pressures during each tomography scan. These data enabled the first digital volume correlation (DVC) measurements in lung tissue to be performed. Quantitative analysis was performed to describe the damaged architecture of the lung. No clear changes in the microstructure of the tissue morphology were observed due to controlled low- to moderate-level blast exposure. However, significant focal sites of injury were observed using DVC, which allowed the detection of bias and concentration in the patterns of strain level. It is important to characterize the non-instantly fatal doses of blast, given the transient nature of blast lung in the clinical setting. This research has highlighted the need for better understanding of focal injury and its zone of influence (alveolar interdependency and neighbouring tissue burden because of focal injury).

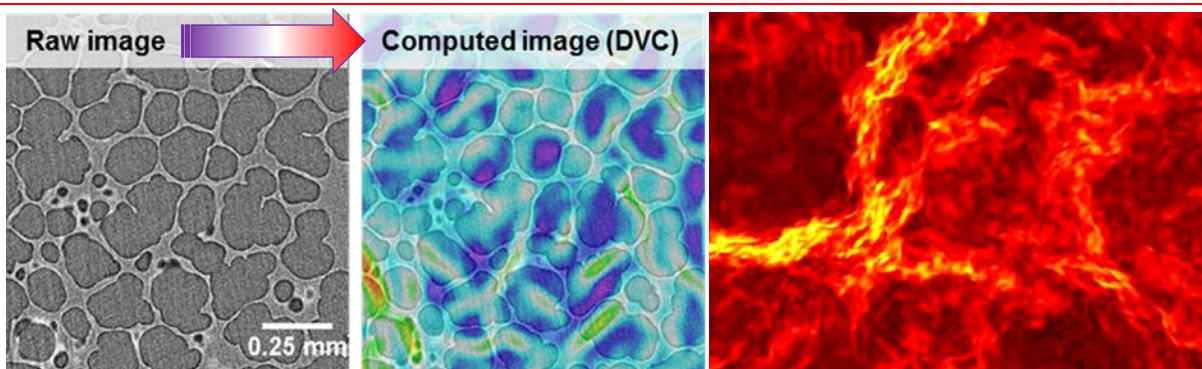

Figure 5: Digital volume correlation strain maps including an injured sample (right)

The aim of the study was to characterise injury in a greater depth than before, enabling comment on residual lung mechanics and provide direct validation of computational models. The information may help to provide explanations for delayed symptoms of lung injury or exacerbation injury during treatment.

Microstructural Consequences of Blast Lung Injury

- First reported measurement of strain within the blast injured lung tissue
- Highlights of sites of injury and zones of lung affected by tissue damage
- New strategies for classifying injury severity will be developed.

Injury representation against ballistic threats using three novel numerical models

Breeze J, Fryer R, Pope D, Clasper J, (2017)

Journal of the Royal Army Medical Corps, 163(3):193-198

Injury modelling of ballistic threats is a valuable tool for informing policy on personal protective equipment and other injury mitigation methods. Currently, the Ministry of Defence (MoD) and Centre for Protection of National Infrastructure (CPNI) are focusing on the development of three interlinking numerical models, each of a different fidelity, to answer specific questions on current threats. High-fidelity models simulate the physical events most realistically, and will be used in the future to test the medical effectiveness of personal armour systems. They are however generally computationally intensive, slow running and much of the experimental data to base their algorithms on do not yet exist. Medium fidelity models, such as the personnel vulnerability simulation (PVS), generally use algorithms based on physical or engineering estimations of interaction. This enables a reasonable representation of reality and greatly speeds up runtime allowing full assessments of the entire body area to be undertaken. Low-fidelity models such as the human injury predictor (HIP) tool generally use simplistic algorithms to make injury predictions. Individual scenarios can be run very quickly and hence enable statistical casualty assessments of large groups, where significant uncertainty concerning the threat and affected population exist. HIP is used to simulate the blast and penetrative fragmentation effects of a terrorist detonation of an improvised explosive device within crowds of people in metropolitan environments. This paper describes the collaboration between MoD and CPNI using an example of all three fidelities of injury model and to highlight future areas of research that are required.

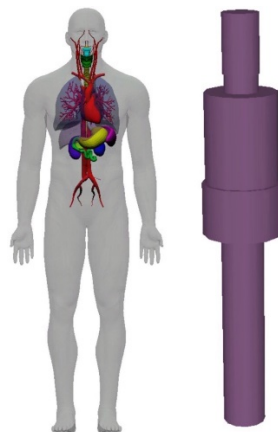

Figure 6: Representations of high (left) and low (right) fidelity models.

Injury representation against ballistic threats

- Injury modelling of ballistic threats is a valuable tool for informing policy on personal protective equipment and other injury mitigation methods
- High-fidelity models simulate the physical events most realistically but are currently computationally intensive and so usually slowest running
- Medium-fidelity models are faster running than high-fidelity solutions but can still use relatively complex representations of human anatomy
- Low-fidelity models enable scenarios to be run very quickly and hence enable statistical casualty assessments of large.

Xenon protects against blast-induced traumatic brain injury in an in vitro model

Campos-Pires R, Koziakova M, Yonis A, Pau A, Macdonald W, Harris K, Edge CJ, Franks NP, Mahoney PF, & Dickinson R. (2017)

Journal of Neurotrauma, 2017, online ahead of print. <https://doi.org/10.1089/neu.2017.5360>

The aim of this study was to evaluate the neuroprotective efficacy of the inert gas xenon as a treatment for blast-induced traumatic brain injury in an *in vitro* laboratory model. We developed a novel blast traumatic brain injury model using organotypic hippocampal brain-slice cultures from mice exposed to a single shockwave, with the resulting injury quantified using propidium iodide fluorescence. A shock tube blast generator was used to simulate open field explosive blast shockwaves, modeled by the Friedlander waveform. Exposure to blast shockwave resulted in significant ($p < 0.01$) injury that increased with peak-overpressure and impulse of the shockwave, and which exhibited a secondary injury development up to 72 hours after trauma. Blast-induced propidium iodide fluorescence overlapped with cleaved caspase 3 immunofluorescence, indicating that shockwave-induced cell death involves apoptosis. Xenon (50% atm) applied 1 hour following blast exposure reduced injury 24 hours ($p < 0.01$), 48 hours ($p < 0.05$) and 72 hours ($p < 0.001$) later, compared to untreated control injury. Xenon-treated injured slices were not significantly different to uninjured sham slices at 24 hours and 72 hours.

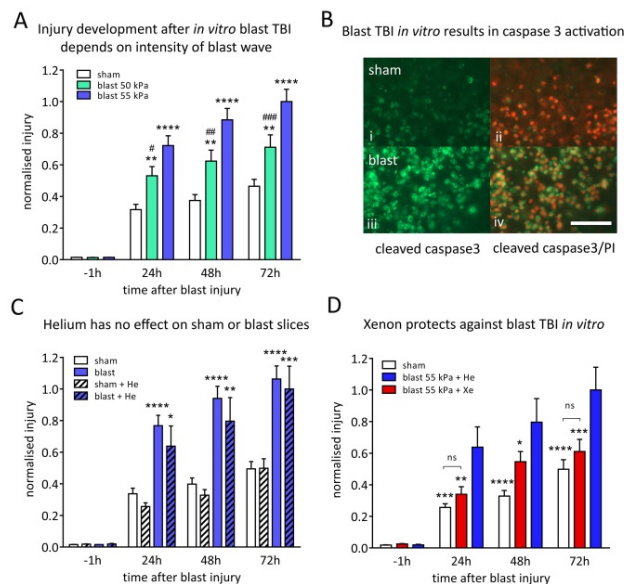

Figure 7: A) Injury development after *in vitro* blast TBI depends on intensity of blast wave, B) Blast TBI *in vitro* results in caspase 3 activation, C) Helium has no effect on sham or blast slices, and D) Xenon protects against blast TBI *in vitro*.

We demonstrate for the first time that xenon-treatment after blast traumatic brain injury reduces initial injury and prevents subsequent injury development *in vitro*. Our findings support the idea that xenon may be a potential first-line treatment for blast-induced traumatic brain injury.

Xenon protects against blast TBI *in vitro*

- We developed a novel *in vitro* model of blast traumatic brain injury using the RBL CBIS shocktube
- Xenon treatment started 1 hour after blast TBI prevented injury development
- This is the first demonstration of xenon neuroprotection in blast injury. Xenon may be a potential first line treatment for blast TBI.

Strain rate dependency of fractures of immature bone.

Cheong VS, Karunaratne A, Amis AA, Bull AMJ (2017)

Journal of the Mechanical Behaviour of Biomedical Materials, 66: 68-76

Bones break in different ways depending on: the way they are loaded, the rate of loading, and the *type* of bone that is failing. Early work in the Centre focused on loading rate effects (strain rate) in tissue failure, yet other effects have not been considered; the approach has previously been to identify the tissue components within a structure (e.g. bone, ligament, cartilage), quantify their properties at different strain rates, and then create a computational model that enables the system response (e.g. of a foot or leg) to be quantified. This approach has proven successful for some tissues and structures, yet it neglects one of the important factors in military-relevant research that is that the subjects can be young. There are known age-dependent material property effects that need to be characterised, particularly for bone. Also, the forensic biomechanical approach used by CBIS, in which medical images of injury are used to understand the loading that has produced that injury, requires a mapping to be created between these injuries and loading and this mapping is best created within a controlled laboratory setting. In this study, advanced experimental test fixtures were developed to create specific loading mechanism. Young bones were tested under complex loading at more than one strain rate for the first time, using a specimen-specific alignment system, to characterise structural behaviour at para-physiological strain rates. The bones behaved linearly to the point of fracture in all cases and transverse, oblique, and spiral fracture patterns were consistently reproduced. The results showed that there was a significant difference in bending stiffness between transverse and oblique fractures in four-point bending. For torsional loading, spiral fractures were produced in all cases with a significant difference in the energy and obliquity to fracture. Multiple or comminuted fractures were seen only in bones that failed at a higher stress or torque for both loading types. This demonstrates the differentiation of fracture patterns at different strain rates for the first time for immature bones and this experimental approach can now be applied to tissues of different ages for incorporation in the computational models used within CBIS to develop novel mitigation and protection.

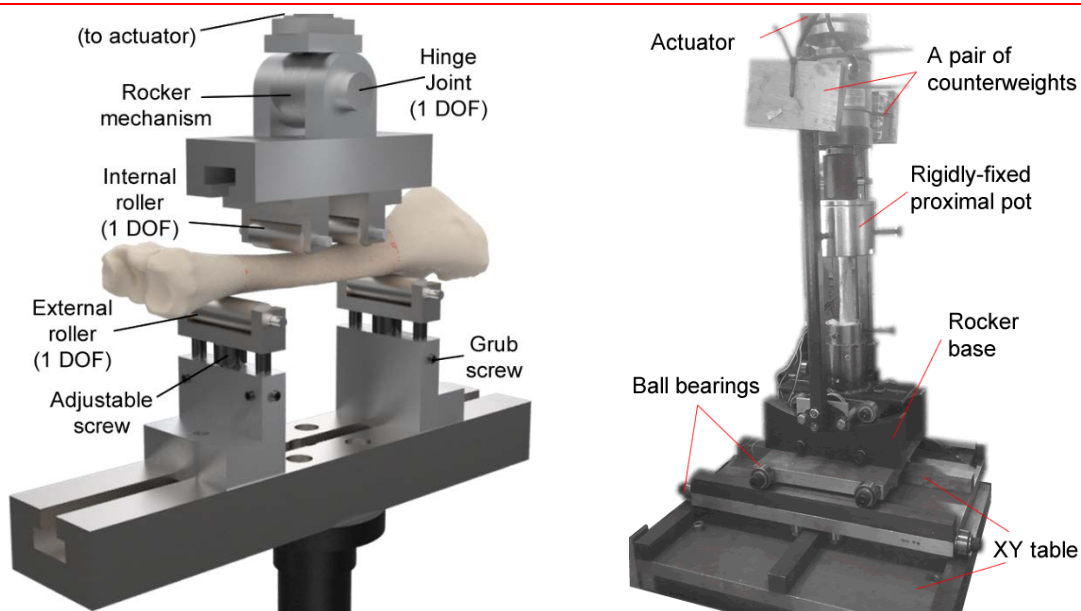

Figure 8: Experimental setup for four point bending (left) and torsional loading (right)

Complex loading of bone: reproducible fractures at different strain rates

- Forensic biomechanics maps observed injuries to the loading mechanism
- Recreating complex loading requires advanced experimental techniques developed here
- Complex loading, varying loading rate, and young bones were tested and found to have reproducible fracture patterns thus confirming the injury mapping postulated

Evaluating Primary Blast Effects *In Vitro*

Logan N, Arora H, Higgins C (2017)

Journal of Visualized Experiments, 127, e55618

Understanding the mechanisms behind blast-induced injuries is of great importance considering the recent trend towards the use of explosives in modern warfare and terrorist-related incidents. To fully understand blast-induced injury, we must first be able to replicate such blast events in a controlled environment using a reproducible method.

In this methods article we used a compressed air-driven shock tube to generate shock waves at a range of pressures, which were propagated over live cells grown in 2D culture. Following this, markers of cell viability were immediately analysed using a redox indicator assay and the fluorescent imaging of live and dead cells. This method demonstrated that increasing the peak blast overpressure to 127 kPa can stimulate a significant drop in cell viability when compared to untreated controls when using rat dermal papilla cells. The method is not limited to immediate assessment as sterility is maintained throughout and exposed cells can be returned to standard culture conditions for long-term assessment.

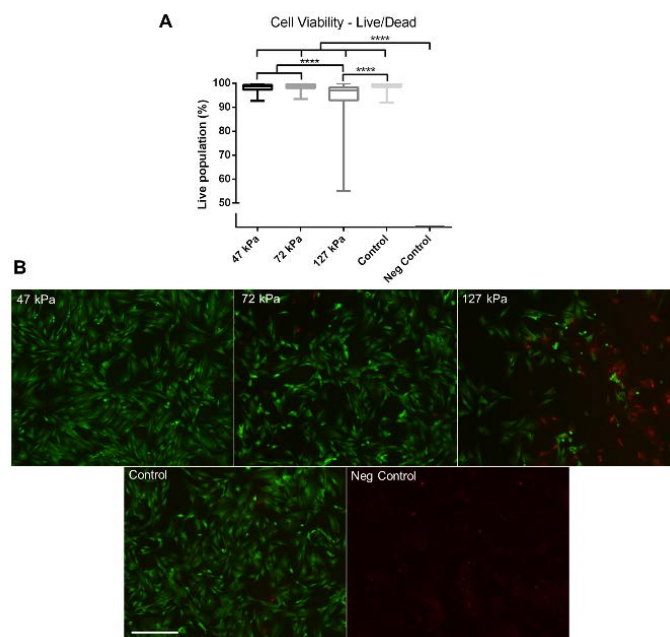

Figure 9: Fluorescence Imaging. (A) Quantitative data gathered from fluorescent images of live and dead cells captured using a fluorescence microscope at 24 h post-shock wave exposure. (B) Representative fluorescence images. Green shows live cells, whilst red shows dead cells. Each box plot shows the upper and lower quartiles with Tukey whiskers; biological replicates, N = 3; technical replicates, n = 13. ** = $p < 0.0001$. Scale bar = 300 μm**

Techniques such as the one presented in this article can help to define damage thresholds and be used to identify the transcriptional and epigenetic changes within cells that arise from shock wave exposure.

In vitro cell culture models can answer questions on a cellular level

- The identification of cell specific responses to shock waves can help us understand the role of this mechanical stimulation in blast associated diseases, such as heterotopic ossification (HO).

Biomechanics of the human intervertebral disc: a review of testing techniques and results

Newell N, Little JP, Christou A, Adams MA, Adam CJ, Masouros SD (2017)
Journal of the Mechanical Behavior of Biomedical Materials, 69: 420-434

Many experimental testing techniques have been adopted to provide an understanding of the biomechanics of the human intervertebral disc (IVD). The aim of this review article is to amalgamate results from these studies to provide readers with an overview of the studies conducted and their contribution to our current understanding of the biomechanics and function of the IVD. The review found that intervertebral disc behaviour can be strongly influenced by the testing environment, preconditioning, loading rate, specimen age and degeneration, and spinal level. Component tissues of the disc (anulus fibrosus, nucleus pulposus, and cartilage endplates) have been studied to determine their material properties, but only the anulus has been thoroughly evaluated. Animal discs can be used as a model of human discs as they provide uniform non-degenerate specimens to experiment with; differences in scale, age, and anatomy, however, can lead to difficulties in interpretation.

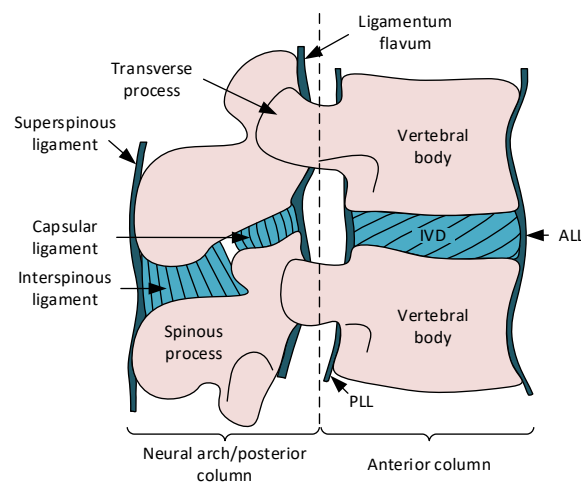

Figure 10: Graphical representation of a spinal motion segment. ALL and PLL refer to the anterior and posterior longitudinal ligaments, respectively. The capsular ligament encloses the zygapophysial joint. The intertransverse ligaments (ITLs) are not shown but they extend between upper and lower borders of the transverse processes.

The aim of the study was to review the literature to determine the research that is required to ensure that the material properties of the intervertebral discs in the spine are well understood for blast related research. The output has shown that high rate characterisation of the discs is necessary. Current research in CBIS is addressing this shortcoming.

Review of intervertebral disc properties

- A wide range of experiments have been performed to characterise the properties of intervertebral discs, predominantly at slow loading rates
- This review summarises results from these experiments in a format useful for experimentalists and computational modellers
- The behaviour of intervertebral discs is rate dependent; therefore, they must be fully characterised at high loading rates for blast related application
- Current work in CBIS is characterising the material behaviour of discs at high loading rates.

Mediastinal injury is the strongest predictor of mortality in mounted blast amongst UK deployed forces

Pearce PA, Bull AMJ, Clasper JC (2017)
Injury, 48(9): 1900-1905

Blast injury has been the most common cause of morbidity and mortality encountered by UK forces during recent conflicts. Previous work has established that head injuries and intra cavity haemorrhage are the major causes of death following exposure to under body (mounted) blast (UBB) but has yet to explore the precise nature of these torso injuries nor the effect of particular injuries upon survival. This study examined the patterns of torso injury within the mounted blast environment in order to understand the effect of these injuries upon survivability.

Injury	Survivor (n=297)	Non-Survivor (n=129)	Total	CFR
Splenic Injury	16 (5.4%)	47 (36.4%)	63	74.6%
Liver Injury	6 (2%)	53 (41.1%)	59	89.8%
Lung Contusion	20 (6.7%)	34 (36.4%)	54	63.0%
GI Injury	8(2.7%)	33 (25.6%)	41	80.5%
Haemothorax	8 (2.7%)	32 (24.8%)	40	80.0%
Kidney Injury	3 (1.0%)	35 (27.1%)	38	92.1%
Cardiac Injury	1 (0.3%)	31 (24.0%)	32	96.9%
Lung Laceration	2 (0.7%)	24 (18.6%)	26	92.3%
Blast Lung	10 (3.4%)	13 (10.1%)	23	56.5%
Other Abdominal Vascular Injury	3 (1.0%)	19 (14.7%)	22	86.4%
Thoracic aorta Injury	0	17 (13.2%)	17	100.0%
Pneumothorax	11 (3.7%)	2 (1.6%)	13	15.4%
Other Thoracic Vascular Injury	1 (0.3%)	4 (3.1%)	5	80.0%
Pulmonary vein Injury	0	4 (3.1%)	4	100.0%
SVC injury	0	2 (1.6%)	2	100.0%
Abdominal Aorta Injury	0	2 (1.6%)	2	100.0%
IVC Injury	0	2 (1.6%)	2	100.0%
Pulmonary artery Injury	0	1 (0.8%)	1	100.0%

Figure 11: Torso injury patterns in dismounted blast for survivors and non-survivors. Case Fatality Rate (CFR) is the ratio of fatalities to total injury incidence.

The aim of the study was to examine those injuries which impact most upon survival within the UBB environment and which are potential biomechanical targets for injury prevention and mitigation. Further work will determine the extent to which current research models and injury criteria address these injuries and develop new physical models to better link the injuries with UBB loading.

Mediastinal injury is the strongest predictor of mortality in mounted blast

- Current trauma scoring methods have little fidelity for describing survivability in the blast environment
- Torso injuries, including those to the heart and great vessels, are the strongest indicators of UBB mortality
- Further work will seek to mechanically link torso injuries to UBB loading.

Failure analysis using X-ray computed tomography of composite sandwich panels subjected to full-scale blast loading

Rolfe E, Kelly M, Arora H, Hooper P, Dear J (2017)
Composites Part B: Engineering, 129: 26-40

The air and underwater blast resistance of glass-fibre and carbon-fibre reinforced polymer sandwich structures has been investigated. In this study, step-wise graded density foam cores were studied. Large test samples (0.5-2.4 m²) were subject to 1.28 kg and 100 kg TNT equivalent charges during the underwater and air blast experiments respectively. The experiments aimed to identify whether alterations to the composite skins or core of a sandwich panel can yield improved blast resilience. Results revealed that implementing a stepwise graded density foam core, with increasing density away from the blast, reduces the deflection of the panel and damage sustained. Furthermore, the skin material affects the extent of panel deflection and damage – highlighted with x-ray computed tomography. The data enables the development of models for optimised design of blast protection.

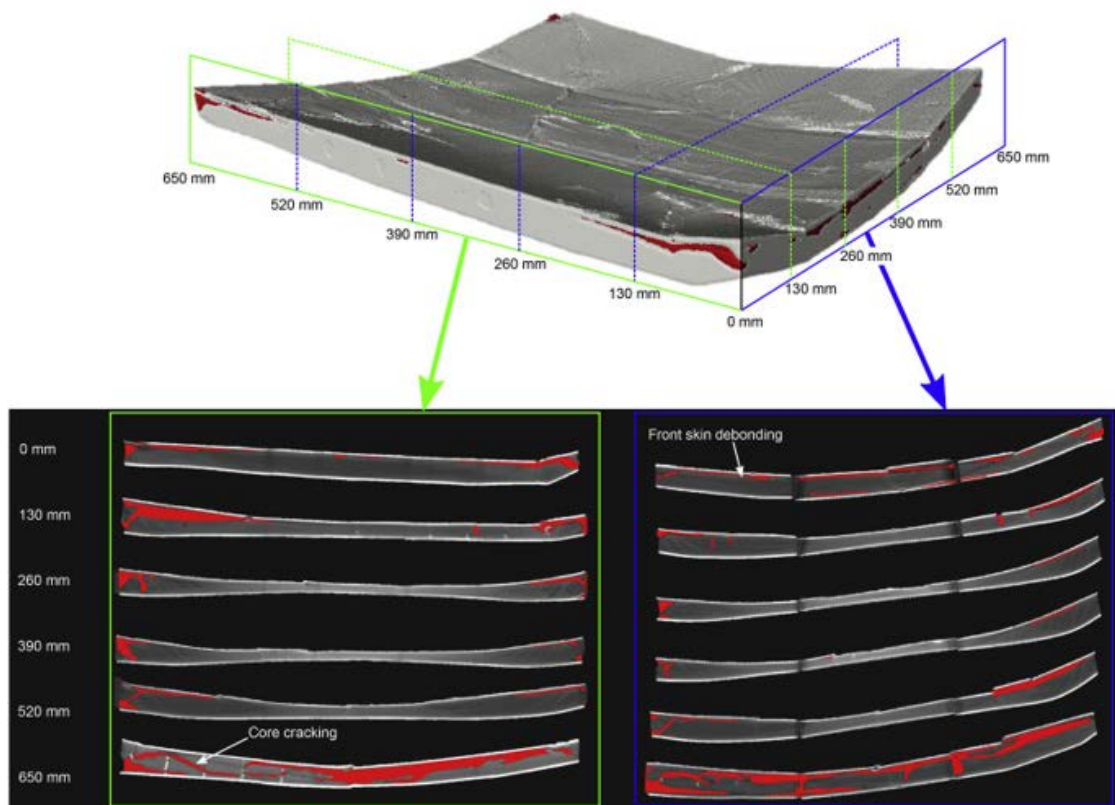

Figure 12: 3D reconstruction and 2D cross-sectional views of single core GFRP panel from X-ray CT scans.

The aim of the study was to establish how materials can be optimised for blast tolerance through material selection and design. The next phase of research builds on the quantitative damage evolution aspect to improve residual load capacity and therefore deliver more durable protective materials.

Failure analysis of composite sandwich panels

- Carbon- and glass-fibre sandwich structures were subject to different types of blast loading
- Damage mechanisms were characterised through use of X-ray computed tomography
- Combinations of material design evaluated are leading to improved protection efficacy.

Surgical Management of Musculoskeletal Trauma

Stinner DJ, Edwards D (2017)

Surgical Clinics of North America, 97(5): 1119-1131

Both on the battlefield and in civilian trauma, extremity injuries are common. In fact, they account for over 50% of the total costs on society for non-fatal injuries. This is due to multiple factors, but highlights the level of disability that can occur after these severe injuries. In order to optimize outcomes of patients with severe musculoskeletal trauma, a multidisciplinary team approach that includes the orthopaedic surgeon as well as the trauma team leader and other surgical, medical, and vocational services to assist with recovery is ideal.

When a polytrauma patient initially presents to A&E, the trauma team will initially resuscitate the patient and dependent on the patient's response and certain clinical factors, there is a decision made to either perform early total care, trying to definitively fix all fractures as quickly as possible, or perform damage control orthopaedics. Damage control orthopaedics is reserved for physiologically unstable or borderline patients and typically involves only doing the necessary surgical interventions to stabilize fractures in an effort to minimize blood loss, improve pain, and promote mobilization. This is typically done with external fixation of the pelvis and/or long bones of the lower extremity, which can be definitively fixed when the patient stabilizes within 1-2 weeks. Early total care is reserved for the physiologically stable patient following resuscitation and has the benefit of allowing the patient to be mobilized earlier following definitively stabilization of their injuries rather than being confined to a recumbent position that is often required following severe polytrauma. While early mobilization with early total care has the benefit of minimizing potential complications such as pulmonary complications, there is a delicate balance of doing too much surgery too early when the patient cannot physiologically handle the trauma of the surgery. This manuscript reviews musculoskeletal trauma care and focuses on this decision-making process.

The aim of the manuscript was to provide a review on the treatment of severe musculoskeletal trauma in the polytrauma patient. This manuscript provides a clinical overview that helps the reader understand the decision making process involved with determining when and how to stabilize fractures.

Surgical Management of Musculoskeletal Trauma

- Damage control orthopaedics (DCO) is reserved for the physiologically unstable or borderline patient
- Early total care (ETC) is often ideal for the management of stable trauma patients with isolated extremity injuries
- Communication between the orthopaedic surgeon, trauma team leader, and other surgical services is paramount to optimize outcomes.

Microscale poroelastic metamodel for efficient mesoscale bone remodelling simulations

Villette CC, Phillips ATM (2017)

Biomechanics and Modeling in Mechanobiology, 16(6): 2077-2091

The study links work by the authors in predicting cortical and trabecular bone structure in the femur, tibia and fibular, based on the loads that bone is subjected to across a range of daily activities, to an improved approach, also developed by the authors, to modelling the adaptation of trabecular bone. Previous adaptive structural modelling of bone was phenomenological, in that it utilised mechanical factors where there is not a clear pathway to how the factors, such as stress or strain, are sensed by cells in the bone. The improved approach took fluid motion, which may be sensed through shearing of cell walls or movement of primary cilia, as the mechanical factor on which to base bone adaptation. As this is computationally intensive a metamodel was developed allowing surrogate strain measurements to be used based from a structural model of the proximal femur based on findings from a poroelastic continuum model of a single trabeculae. This study presents findings using the metamodel approach to predict the structure of the proximal femur compared to the structure predicted for a control structural model. The metamodel allows elements to reorientate, which the control model does not. Figure 13 shows the predicted structure of the proximal femur using the two modelling approaches. The metamodel resulted in an improved prediction of trabecular trajectories in the proximal femur. The approach can be applied in the assessment and prediction of bone health in amputees, in combination with gait and musculoskeletal analysis on altered loading patterns, including those produced by rehabilitation exercise regimes.

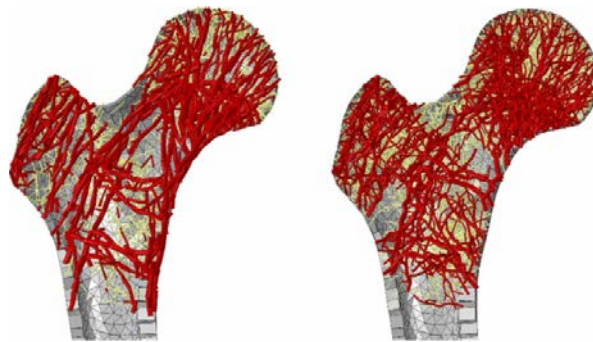

Figure 13: Structural of the proximal femur predicted using the (left) metamodel and the (right) control.

The aim of the study was to improve bone structure prediction using a metamodel that could be developed to be informed by the altered response of bone cells following exposure to blast or impact insult. The developed structures also have the potential to be manufactured using 3D printing for the development of novel implant designs or bone tissue engineering scaffolds.

Metamodel for bone adaptation

- Improved approach to trabecular bone structure prediction
- Application in predicting and maintaining bone health in amputees
- Application in predicting altered bone response to loading following blast injury
- Application in design of novel implants and bone tissue engineering scaffolds.

Tensile Characterisation of the Aorta across Quasi-static to Blast Loading Strain Rates

Magnus D, Haller A, Jouffroy A and Proud WG. (2017)
AIP Conference Proceedings, 62(9).

Dynamic tensile failure of the aorta during traumatic events is poorly understood. Aortic rupture in automotive incidents is the second most common cause of mortality while, in the higher strain rate regime of blast, this injury has also been observed in humans. In order to obtain a more complete understanding of the injury mechanism, the aorta must be mechanically characterised across a wide range of strain rates.

The aims were to present initial results for quasi-static tensile characterisation of murine aorta and the corresponding development of CBIS platforms. Further experimental considerations and key challenges for testing at higher strain rates up to the order of 1000s^{-1} were discussed

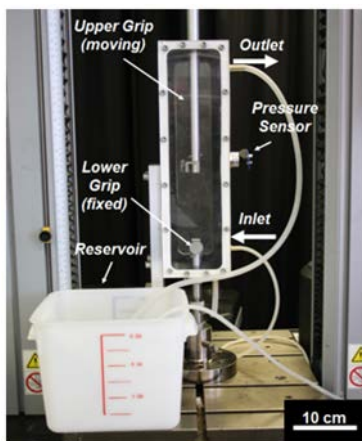

Figure 14: Chamber for quasi-static tensile testing of soft tissues.

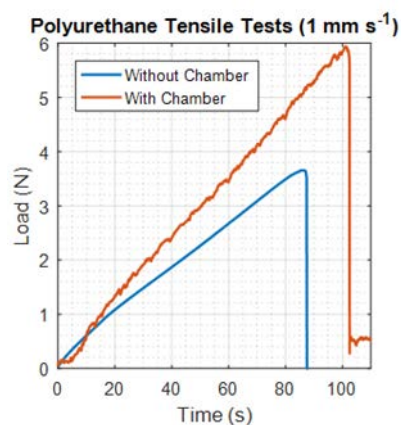

Figure 15: Tensile tests of polyurethane with and without the chamber.

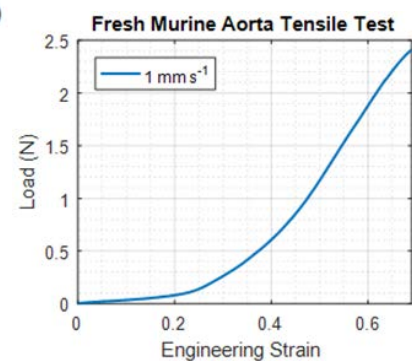

Figure 16: Tensile test for a fresh murine aortic sample at 1mm s^{-1} extension rate.

The aorta has a layered heterogeneous structure of primarily elastin and collagen, providing elasticity and strength respectively. Circumferential orientation of the elastin in the aortic wall is a rationale for why aortic rupture has been commonly observed in the transverse direction, given a dynamic tension failure mechanism. Quasi-static tensile tests were performed on fresh murine aortic samples with a length of 2 cm and diameter of approximately 2 mm. Long timescale experiments with very soft biomaterials raise time-dependent challenges as the specimen dries, such as increasing stiffness. To address this, a temperature and pressure controlled chamber was developed (Fig. 14) and characterised with polyurethane dog-bone samples (Fig. 15). By submerging the sample in a saline solution, drying is prevented. An example test for a fresh murine sample is shown in Fig. 16. The linearity following 20% strain is attributed to loading of the elastin. Hopkinson Bar techniques may be used for higher strain rate experiments where stress transmission, sample gripping and sample inertia will be the primary challenges.

Tensile Characterisation of the Aorta

- Dynamic tensile failure of the aorta occurs under blast but is poorly understood.
- Methods for quasi-static characterisation of aortic samples have been developed
- The elastin and collagen content of the aorta as well as their arrangement, are important in determining its mechanical behaviour

The Response of Simple Polymer Structures to Dynamic Loading.

Proud WG, Ellison K, Yapp SH, Cole C, Galimberto S (2017)
AIP Conference Proceedings, 62 (9)

Blast mitigation and the reduction of the initial insult to the body is the 'preventative' medicine of the blast injury world. In this area CBIS has pioneered a series of loading platforms that reproduce the various effects of blast in a controlled, laboratory environment. These platforms can also be used to study the fundamentals of injury mitigation. In this study we study a simple polymer structure and determine how modifications affect its energy absorption and ultimate failure. This information is key to developing more effective, light-weight, fit-for-purpose mitigation systems.

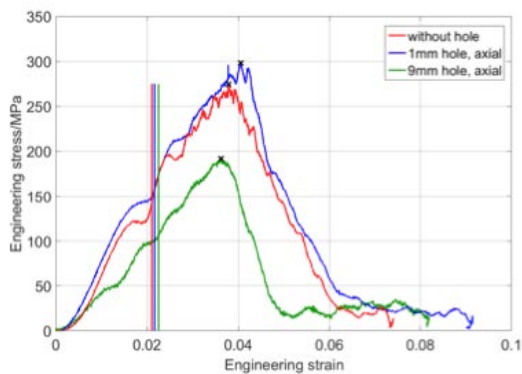

Figure 17: The engineering stress- engineering strain curve recorded for samples with no hole, a 1 mm axial hole and a 9 mm axial hole struck at the same input level and resulting in failure. After the maximum peak was reached the drop represents damage and pulverization

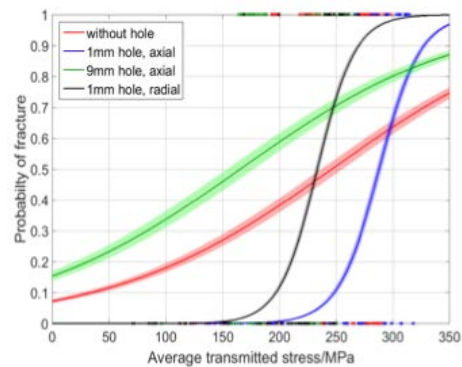

Figure 18: The probability of failure, defined as the presence of one visible crack versus peak stress transmitted by sample type, averaged over the repeats used.

The dynamic response of polymeric materials has been widely studied with the effects of degree of crystallinity, strain rate, temperature and sample size being commonly reported. This study uses a simple PMMA structure, a right cylindrical sample, with structural features such as holes. The features are varied in a systematic fashion. Samples were dynamically loaded using a Split Hopkinson Pressure Bar up to failure at room temperature. The resulting stress-strain curves are presented showing the change in sample response. The strain to failure is shown to be relatively unaffected by the presence of holes, while failure stress is changes significantly. The fracture patterns seen in the failed samples, varies with loading; tensile cracks, cone cracks and radial fracture. Shear effects are the dominant initial form of failure for the different hole sizes and geometries. The samples were prepared by laser cutting and checked for residual stress before experiment. This presentation of empirical results will be used to develop new failure surfaces for PMMA and validate predictive model predictions where material, structure and damage are included.

Simple Polymer Structures To Dynamic Loading

- The dynamic response of materials is dependent on material and type and structure. Knowledge of this relationship will improve blast mitigation
- A polymer cylinder absorbs more energy and is stronger if there is a pre-existing hole along its central axis
- This type of study is unique in that it takes a very simple structure and studies it in depth. Many other approaches study complex structure in limited depth.

In the Spotlight

In the Spotlight takes a look at significant related work published this year by researchers at key partner institutes who have either built on the output of the Centre, or have generated findings of significant use to its current research goals. We also look at key publications from researchers associated with CBIS that is either core science or technology that will now be used for CBIS related research. Here we present work from two different areas; one paper looks at traumatic brain injury, and the other two are looking at hearing impairments.

[Ghajari M, Hellyer PJ, Sharp DJ \(2017\). Computational modelling of traumatic brain injury predicts the location of chronic traumatic encephalopathy pathology. *Brain*. 140. pp 333-343](#)

Brain exposure to mechanical forces, including blast, can lead to the neurodegenerative disease chronic traumatic encephalopathy (CTE). The signature pathology of CTE is deposition of tau proteins in depths of sulci, particularly in a perivascular location. The authors test the hypothesis that mechanical strain and strain rate, which are measures of brain deformation and its rate of deformation, are largest in the depths of sulci. They simulated three injuries using their high fidelity computational model of traumatic brain injury, including a sporting incident, a fall and a road traffic accident. The results show that largest strains and strain rates are focused in sulcal regions for all three injuries. The team also analysed diffusion images of a large number of TBI patients, which also showed that abnormalities are focused in the depths of sulci, providing converging evidence for their computational predictions. This work can help inform the design of prevention strategies, such as helmets, and is now being used in the Centre.

[Forte AE, Etard O, Reichenbach T. \(2017\). The human auditory brainstem response to running speech reveals a subcortical mechanism for selective attention. *eLife*. 6. pp e27203](#)

Humans excel at selectively listening to a target speaker in background noise such as competing voices. While the encoding of speech in the auditory cortex is modulated by selective attention, it remains debated whether such modulation occurs already in subcortical auditory structures. Investigating the contribution of the human brainstem to attention has, in particular, been hindered by the tiny amplitude of the brainstem response. Its measurement normally requires a large number of repetitions of the same short sound stimuli, which may lead to a loss of attention and to neural adaptation. In this paper the authors develop a mathematical method to measure the auditory brainstem response to running speech, an acoustic stimulus that does not repeat and that has a high ecological validity. They employ this method to assess the brainstem's activity when a subject listens to one of two competing speakers. This work is important for further understanding hearing deficits in military veterans and is now being using in the Centre.

[Bressler S, Goldberg H, Shinn-Cunningham B \(2017\). Sensory coding and cognitive processing of sound in Veterans with blast exposure. *Hearing Research*, 349: 98-110.](#)

The study investigates hearing impairments in veterans with blast exposure. Although most of the participants report difficulty with hearing in noisy environment, most of them have functional hearing at the stage of the outer, middle and inner ear. However, the authors find impaired cognitive processing of sound in the cerebral cortex of the blast-exposed veterans which could cause their difficulty with speech-in-noise comprehension. The work therefore evidences a central role that cortical impairment plays for hearing deficits in veterans with blast exposure, a topic that we are investigating within CBIS.

Imperial College
London



THE ROYAL BRITISH LEGION

CENTRE FOR BLAST INJURY STUDIES

AT IMPERIAL COLLEGE LONDON

