

Imperial College  
London

# Centre for Bio-Inspired Technology

Annual Report 2017





**Centre for Bio-Inspired Technology**  
Department of Electrical  
and Electronic Engineering  
Imperial College London  
South Kensington  
London SW7 2AZ

T +44 (0)20 7594 0701

F +44 (0)20 7594 0704

bioinspired@imperial.ac.uk

[www.imperial.ac.uk/  
bioinspiredtechnology](http://www.imperial.ac.uk/bioinspiredtechnology)

 @ImperialCBIT

# Centre for Bio-Inspired Technology

## Annual Report 2017

---

- 3 Director's foreword**
- 4 Founding Sponsor's foreword**
- 5 People**
- 7 Our news**
- 10 Reflections from alumni**
- 12 Research strategy**
  - 13 Genetic technology
  - 14 Metabolic technology
  - 15 Neural technology
  - 16 Cancer technology
  - 17 Bio-modelling
- 18 Research funding**
- 19 Featured research**
  - 20 Neural technology – tools and resources for neuroscience
  - 22 Ultra-wideband radar-on-chip for medical imaging and biosensing
  - 24 ARISES: An Adaptive, Real-time, Intelligent System to Enhance Self-care of chronic disease
  - 25 Novel angioplasty catheter for treatment of calcified arteries
- 26 Expert perspectives: two visiting professors share their views**
- 28 Chip gallery**
- 30 XCBIT Research Gallery**
- 32 Research facilities**
- 35 Who we are**
  - 36 Academic staff profiles
  - 41 Administrative staff profiles
  - 42 Staff research reports
  - 64 Research students' and assistants' reports

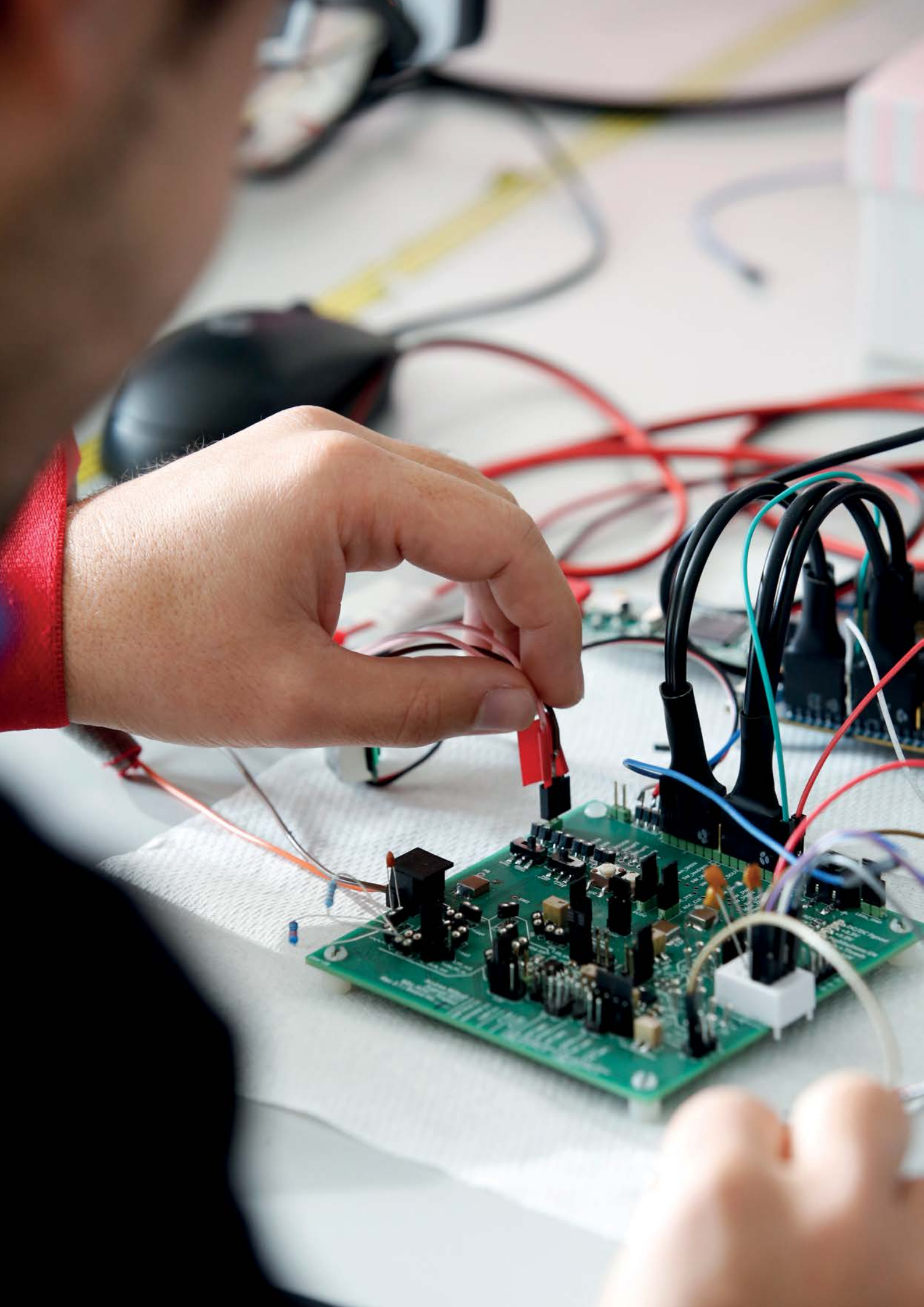

# Director's foreword



The Centre for Bio-Inspired Technology is built upon the ingenuity and hard work of its members and it is my pleasure to report continued recognition of these efforts with another successful year of grants, promotions and awards. British research faces an important transition over the next few years, making it important not only to reflect upon the many successes within the Centre over the past year but also to reaffirm our commitment to our EU and international members who comprise more than 80% of our Centre.

2017 has been an exciting year for many of our research endeavours at CBIT. The EPSRC funded EMBRACE project showcased the challenges of antimicrobial resistance in a summer workshop, and orchestrated a Dragon's Den competition to enable researchers to show how they can contribute to tackling these challenges. This was followed by the Technology vs Infectious Diseases summit at the Royal Institute organised by the EMBRACE group. Dr. Timothy Constandinou brought CBIT to the World Economic Forum (WEF) in China, where he presented a talk on

the next generation of brain machine interfaces at the Annual Meeting of the New Champions. We are incredibly proud of the achievement of Dr. Melpomeni Kalofonou in being awarded a CRUK Multidisciplinary Award for her proposal "Mi-CARE: A Microchip-based diagnostic Companion for Early Detection and Therapeutic Monitoring of Breast Cancer". We look forward to seeing the research that this project brings to light in the coming years.

We had an impressive turn out at BIOCAS 2017, with no less than 13 members of CBIT presenting their work in Turin. Projects ranged from brain machine interfaces to lab-on-chip devices that truly highlight the interdisciplinary and continually innovative nature of the researchers at CBIT. The 2017 ISCAS had a similarly strong representation from the CBIT group, with one of our demos "Real-Time Chemical Imaging of Ionic Solutions Using an ISFET Array" being short-listed as a runner-up for the best live demo award.

It's particularly gratifying to see the group's output recognised for quality as well as quantity. We congratulate Dr Pantelis Georgiou for a particularly stellar year – gaining a promotion to Reader, attaining the prestigious award of IEEE Distinguished Lecturer, and being awarded the IEEE Sensors Technical Achievement award. We also commend our former colleague Dr. Nir Grossman for his appointment as a Lecturer at the Division of Brain Sciences at the Department of Medicine, and for becoming a Founding Fellow at the UK Dementia Research Institute.

Whilst we celebrate these recent successes, we continue to strive for more. We're delighted to see two of our PhD students pass their vivas this year and welcome four more into the fold. Once again, the Centre has attracted the brightest and best within Imperial's prestigious Centres for Doctoral Training. Our commitment to teaching and training the young talent within Imperial lays the foundation for our future success.

Finally, the interdisciplinary work of the group attracts not just the next generation of leaders in science and engineering but also established academics from around the world. This year we welcome four new members of staff from Poland, Ireland, and the London-based Medical Research Council, and the London CSC, forging new partnerships and strengthening existing ones. We look forward to another year as an international hub of collaboration and innovation.

**Professor Chris Toumazou**  
**FRS, FEng, FMedSci,**  
**Regius Professor of Engineering**

# Founding Sponsor's foreword

The Centre for Bio-Inspired Technology has continued to thrive as one of the world's leading centres for biotechnology. As a hub of intellect from the disciplines of electrical engineering, bioengineering, and neurotechnology amongst many more, researchers at CBIT are tackling some of the biggest health challenges in the world today.

In pursuit of these aims, it has been my pleasure to watch the investigators secure independent funds to continue their work and develop their research from the laboratory to the clinic. Knowledge transfer in this way has always been one of the core principles of the Centre. While translating research to medical application is a long and arduous process, it is fundamental to our fight against cancer, diabetes and obesity to name just a few of the life-threatening conditions for which the Centre is actively developing therapies.

It is therefore especially gratifying to witness so many of these projects gain critical mass to have an impact in the medical and commercial worlds. The Centre has enjoyed success in many diverse fields in this way through publications, products and spin-out companies. It is through such products that engineering and academia directly benefit society.

The breakthrough work and recognised successes of the Centre bolsters its proven track record as it continues to spearhead new initiatives for tough and pressing problems. In turn, the reputation grows and attracts more talented researchers and more funding awards to begin new and ever more ambitious projects. As this circle completes, we look forward to many more successful years of innovation in the future.

**Professor Winston Wong OBE,  
BSc, DIC, PhD, DSc**





# People

## Academic & senior research staff

### **Professor Chris Toumazou FRS, FEng, FMedSci**

Regius Professor of Engineering;

Director, Centre for Bio-Inspired Technology;

Chief Scientist, Institute of Biomedical Engineering;

Winston Wong Chair in Biomedical Circuits,

Department of Electrical and Electronic Engineering

### **Timothy G Constandinou, PhD**

Reader, Department of Electrical and Electronic

Engineering;

Deputy Director, Centre for Bio-Inspired Technology

### **Pantelis Georgiou, PhD**

Reader, Department of Electrical and Electronic

Engineering;

Head of Bio-Inspired Metabolic Technology Laboratory

### **Professor Chris N McLeod**

Principal Research Fellow

### **Konstantin Nikolic, PhD**

Senior Research Fellow

## Research staff

### FELLOWS

Reza Bahmanyar, PhD

Nir Grossman, PhD

Pau Herrero Vinas, PhD

Nishanth Kulasekeram

Yan Liu, PhD

Jesus Rodriguez Manzano, PhD

### JUNIOR RESEARCH FELLOWS

Sara Ghoreishizadeh, PhD

### OFFICERS

Laszlo Grand, PhD

### ASSOCIATES

Mohamed El-Sharkawy, PhD

Caroline Golden, PhD

Melpomeni Kalofonou, PhD

Lieuwe Leene, PhD

Kezhi Li, PhD

Chengyuan Liu, PhD

Sara de Mateo Lopez, PhD

Song Luan, PhD

Katarzyna Szostak

Huan Wang, PhD

Krzysztof Wildner, PhD

Ian Williams, PhD

Longfang Zou, PhD

Ling-Shan Yu, PhD

### ASSISTANTS

John Daniels

Dorian Hacı

Bernard Hernandez

Khalid Mirza

### RESEARCH STUDENTS

Nur Ahmadi

Miguel Cacho (started October 2017)

Chen Chih-Han

Matthew Douthwaite

Peilong Feng

Amparo Guemes Gonzalez (started October 2017)

Bryan Hsieh

Timo Lauteslager

Xiaoran Liu

Dora Ma

Kenny Malpartida Cardenas (started October 2017)

Michal Maslik

Federico Mazza

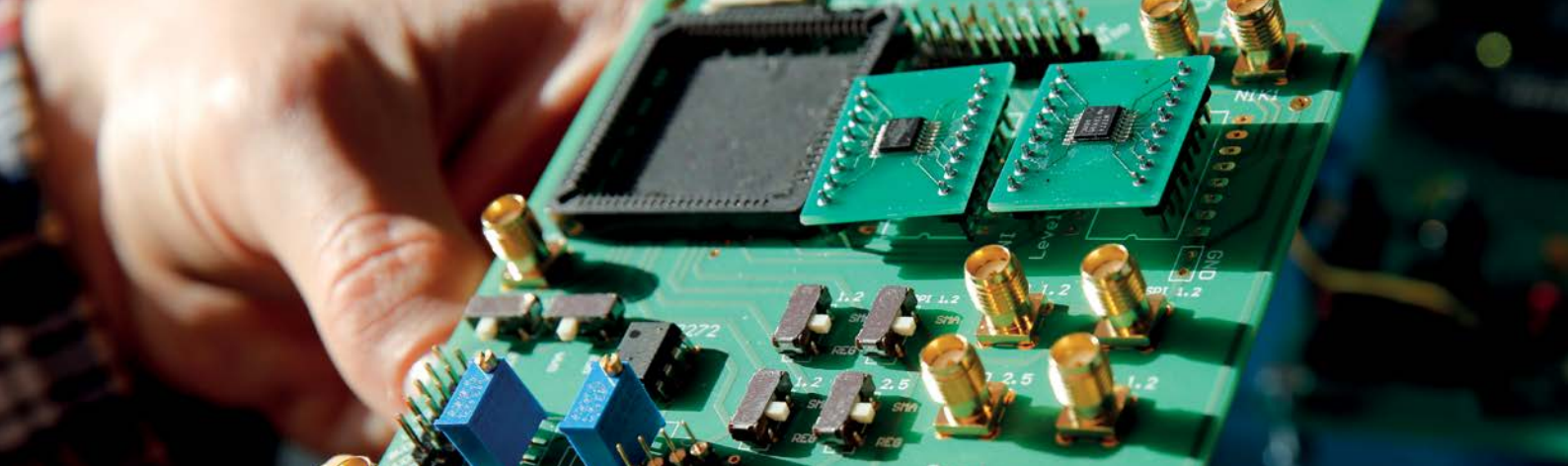

**Nicholaos Miscourides**

**Nicolas Moser**

**Christoforos Panteli**

**Adrien Rapeaux**

**Francesca Troiani**

**Siwei Xie**

## Administrative staff

**Joao Reis**

Project Administrator (part-time)

**Wiesia Hsissen**

Senior Group Administrator (CAS)

**Gifty Kugblenu**

PA to Professor Toumazou

**Izabela Wojcicka-Grzesiak**

Senior Research Centre Administrator (CBIT)

## Visiting academics

### PROFESSORS

**Professor Alyssa Apsel**

Cornell University

**Professor Tor Sverre Lande**

University of Oslo

**Professor Andrew Mason**

Michigan State University

**Professor David Skellern**

Formerly Macquarie University, Australia

**Professor Winston Wong, OBE**

Grace THW, Taiwan

**Professor Sir Magdi Yacoub FRS**

National Heart & Lung Institute, Harefield Hospital

## Researchers

**Alison Burdett, PhD**

Sensium Healthcare Ltd., UK

**Jamil El-Imad, PhD**

W Investments, Switzerland

**Julio Georgiou, PhD**

University of Cyprus

**Miguel Silveira, PhD**

ADCare Ltd, UK

**Professor Themis Prodromakis**

University of Southampton

## Graduates in 2016–2017

**Ermis Koutsos, PhD**

**Mohamed El-Sharkawy, PhD**

## Researchers who have taken up appointments elsewhere

**Yufei Liu, PhD**

**Nicoletta Nicolaou, PhD**

University of Reading

**Nour Shublaq, PhD**

DNAe Electronics Ltd

**Deren Barsakcioglu, PhD**

Dept of Bioengineering, Imperial College London

**Benjamin Evans, PhD**

University of Exeter

**Mohammadreza Sohbaty, PhD**

dnaNUDGE Ltd

**Peter Pesl, PhD**

Austrian Embassy

**Onur Guven, PhD**

Dept of Medicine, Imperial College London



# News

## Staff and events

OCTOBER 2017

### IEEE BIOMEDICAL CIRCUIT & SYSTEMS (BIOCAS) CONFERENCE

Tim Constandinou, Pantelis Georgiou, Yan Liu, Melpomeni Kalofonou, Sara Ghoreishizadeh, Dorian Haci, Nicolas Moser, Federico Mazza, Matt Douthwaite, Katarzyna Szostak, Peilong Feng, Christoforos Panteli and EEE student graduates Andrea Misfud and Daryl Ma attended the conference, presenting and demonstrating latest research work in a range of exciting topics, from brain machine interfaces and implantable electronics to wearable biosensing systems and Lab-on-Chip diagnostics. In total CBIT members presented 12 papers.



*CBIT researchers in Turin, Italy attending BioCAS 2017 together with the conference chairs Danilo Demarchi and Sandro Carrara.*

Two of the papers presented received best paper awards:

- Daryl Ma, Christina Mason, Sara Ghoreishizadeh “Wireless system for continuous in-mouth pH monitoring” (received best student paper award)
- Peilong Feng, Pyungwoo Yeon, Maysam Ghovanloo, Timothy Constandinou “Millimeter-scale Integrated and Wirewound coils for Powering Implantable Neural Microsystems” (received 3rd best paper award).

### BROADCOM FOUNDATION BRAIN INSPIRED COMPUTING & TECHNOLOGIES WORKSHOP

**Researchers from CBIT attended the EMEA Student Research Workshop sponsored by the Broadcom Foundation for Brain Inspired Computing & Technologies. 16–18 Oct 2017, Tel Aviv, Israel.**

The aim of this workshop was to bring together seven top graduate students from each of the partnering universities (Imperial College London; University College Dublin; Indian Institute of Science, Bangalore; Tel Aviv University) to explore rapidly advancing cross-disciplinary inquiries into how “to engineer the brain.” Dorian Haci, Federico Mazza, Timo Lauteslager and Amparo Guemes, under the lead of Dr Pantelis Georgiou, were part of the Imperial College Team.

The workshop focused on emerging integrated research between engineering, neuroscience and computer science aiming to build long-term collaborations between the students. During the workshop, the attendees work in interdisciplinary teams to design new collaborative projects, which were then presented in front of a jury of experts. The workshop also included tours around Israel (Jerusalem and the Dead Sea) and other social events.



*Researchers from CBIT attended the EMEA Student Research Workshop for Brain Inspired Computing & Technologies. 16–18 Oct 2017, Tel Aviv, Israel.*

SEPTEMBER 2017

### DR PANTELIS GEORGIU PROMOTED TO READER

**The Director of Metabolic Technology in the Centre has been promoted to Reader in the Department of Electrical and Electronic Engineering.**

Pantelis originally joined the department as an undergraduate student in 2000. After completing his PhD in 2008, he then moved to the Institute of Biomedical Engineering and in 2009 he was appointed as a research fellow with a focus in diabetes technology. In 2010, he became director of metabolic technology within the Centre for Bio-Inspired Technology and then re-joined the EEE Department as academic faculty in 2011, as a Lecturer in the Circuits & Systems Research group. He continues to maintain his role in the Centre and also leads the research theme in Metabolic Technology.

## TECHNOLOGY VS INFECTIOUS DISEASES

On the 26th September, EMBRACE had its biggest event to date with over 200 attendees throughout the day at The Royal Institution in Mayfair.

The Technology vs Infectious Diseases Summit revealed how the best in UK research and innovation is helping to combat bacterial, viral, parasitic and fungal diseases around the world.



AUGUST 2017

## IEEE TECHNICAL ACHIEVEMENT AWARD

Dr Pantelis Georgiou receives IEEE Technical Achievement Award.

On August 31st Dr. Pantelis Georgiou was awarded the IEEE Sensors Council Technical Achievement in the area of Sensor Systems or Networks for significant contributions to bioelectronics through the development of the Bio-inspired Artificial Pancreas and innovations in Ion-Sensitive Field Effect Transistors for rapid diagnostics. The award was presented on 1 November 2017 at the IEEE Sensors 2017 Conference in Glasgow.



## DR PANTELIS GEORGIU BECOMES AN IEEE DISTINGUISHED LECTURER FOR CIRCUITS AND SYSTEMS

IEEE Distinguished Lecturers are engineering professionals chosen by the IEEE to lead their fields in new technical developments that shape the global community.

In August 2017 Dr Georgiou was invited to Taiwan to give talks at NTHU-Hsinchu NCKU-Tainan NCTU-Kaohsiung VLSI/CAD conference – Kenting and NTU-Taipei as part of the DL program.



JULY 2017

## EMBRACE DRAGON DENS COMPETITION

EMBRACE introduced the challenges we are facing in antimicrobial resistance in its summer workshop on 14 July.

The workshop showed how multidisciplinary research can help tackle this threat, and in its Dragons' Den Competition invited PhD students and early career post-doctoral researchers, to showcase how their research can contribute to addressing the challenges of AMR.



JUNE 2017

## WORLD ECONOMIC FORUM (WEF) ANNUAL MEETING OF THE NEW CHAMPIONS (AMNC17)

Dr Timothy Constandinou participated in the 2017 Annual Meeting of the New Champions in Dalian, China from 27–29 June 2017.

During the event he contributed to the “Unpacking New Medical Paradigms with Imperial College London” IdeasLab and also a ScienceHub feature on “Empowering Next Generation Implantable Brain Machine Interfaces”.



*“Empowering Next Generation Implantable Brain Machine Interfaces” presented by Timothy Constandinou at the WEF Annual Meeting of the New Champions 2017 in Dalian, China.*

View online: <https://www.youtube.com/watch?v=oflOo4G9sns>



MAY 2017

## IEEE INTERNATIONAL SYMPOSIUM ON CIRCUITS & SYSTEMS (ISCAS) CONFERENCE

CBIT group and 50th edition of the IEEE ISCAS Conference 2017 in Baltimore, USA

Michal Maslik, Nicholas Miscourides, Onur Guven, Radu Berdan, Nicolas Moser, Dorian Haci, Melpomeni Kalofonou, Pantelis Georgiou, Timothy Constandinou, Lieuwe Leene attend and present their work at the 2017 IEEE ISCAS Conference in Baltimore, USA from 28–31 May 2017. In total CBIT presented 9 papers.

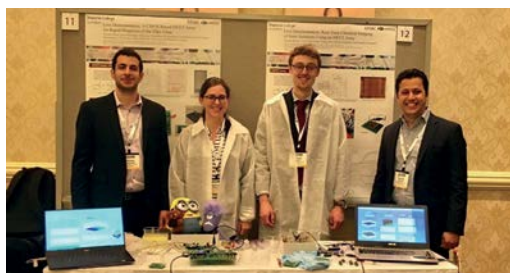

The demo “Real-Time Chemical Imaging of Ionic Solutions Using an ISFET Array” by Nicolas Moser, Chi Leng Leong, Yuanqi Hu, Martyn Boutelle and Pantelis Georgiou was shortlisted as runner-up for the best demo award at this year’s IEEE International Symposium on Circuits and Systems.

## BIO-INSPIRED ARTIFICIAL PANCREAS AT THE ROYAL INSTITUTION

The Imperial College CBIT diabetes team introduced the bio-inspired artificial pancreas at the family fun day event on Saturday 13th May 2017 at the Royal Institution.

The demo allowed children and adults to feed Master Yoda and witness the controller keep his glucose values in range. The event was held to engage children in science.



FEBRUARY 2017

## CBIT SPINOUT – DNAE ANNOUNCES OPENING OF US FACILITY

DNA Electronics (‘DNAe’), the inventors of semiconductor DNA sequencing technology and developers of a new, revolutionary blood-to-result test for bloodstream infections, announces the opening of its new US facility in preparation for commercializing its first product.

Located in Carlsbad, California, DNAe’s new site expands its operations in the US and provides a specialized development and manufacturing base for its first product under the LiDia™ brand. The facility was officially opened by the Mayor of Carlsbad, Matt Hall and Councilman Michael Schumacher with a ribbon-cutting ceremony on 21st February 2017.

Housing 15,000 square feet of laboratories including specialized cleanrooms and 9,000 square feet of office space, the Carlsbad site currently employs 38 people following relocation from the Company’s previous facility in Albuquerque, NM, with recruitment still ongoing.



JANUARY 2017

## BEHIND THE SCENES @ NGNI

Behind the Scenes @ NGNI event for Friends of Imperial College on 25th January 2017.

The Next Generation Neural Interfaces (NGNI) lab hosted a "Behind the Scenes" event for Friends of Imperial College on the evening of 25th January 2017. This event included a welcome and seminar on neural interfaces, lab tours and research demonstrations, and an interactive poster session with the entire group.

Event page: [www.imperial.ac.uk/neural-interfaces/news-and-events/friendsofic](http://www.imperial.ac.uk/neural-interfaces/news-and-events/friendsofic)



## REGIUS PROFESSOR CHRIS TOUMAZOU RECEIVES THE ELECTRA LIFETIME ACHIEVEMENT AWARD

Presented by electronics industry magazine Electronics Weekly, the award recognises Professor Toumazou's pioneering career founded on his visionary application of electronic engineering to solve complex biological problems.

His achievements have included the invention and roll-out of several life-changing products based on semiconductor technology, such as miniature cochlear implants and an artificial Pancreas.

Professor Toumazou's invention of semiconductor genomic analysis has revolutionised next generation sequencing in laboratories around the world. DNAe was founded to develop this Genalysis® technology for use in rapid diagnostics with its first product being a ground-breaking test for serious blood infections leading to sepsis, an area of huge unmet medical need.



CBIT director, Regius Professor Chris Toumazou was presented with the Electra Lifetime Achievement Award at the 14th annual ceremony in recognition of his dedication to saving and improving lives through leading-edge medical research.

DECEMBER 2016

## PRESIDENTS AWARD FOR EXCELLENCE IN RESEARCH SUPERVISION

Dr Timothy Constandinou receives the President's Award for Excellence in Research Supervision.

The award celebrates and acknowledges staff who are considered to have made an outstanding contribution towards a supportive environment.



Dr Timothy Constandinou receiving the President's Award for Excellence in Research Supervision at the 2016 ceremony.

OCTOBER 2016

## CANCER TECHNOLOGY SHOWCASE

Dr Kalofonou presented her work in a series of workshops and seminars including the Circulating Cancer Markers workshop (October 2016), organised by the Cancer Research UK Imperial Centre, the World Precision Medicine Congress 2017 (May 2017), the annual science festival Pint of Science under the theme 'Our body: Medicine, Human Biology: Technology More Important than your Smartphone', representing Imperial College research on engineering in medicine and particularly the role of technology in breast cancer diagnostics and the Microsoft London – Hackathon Week 2017 (July 2017).



Right: Dr Kalofonou presenting her work on breast cancer diagnostics at the Pint of Science festival.

# Reflections from Alumni



**ONUR GUVEN, PhD**

After my bachelor studies, Imperial College has been the academic home for me. I completed my MSc degree in the Department of Electrical and Electronic Engineering. I was then employed as a Research Assistant and I completed my PhD studies in the Centre for Bio-Inspired technology (CBIT).

I cannot even explain how great the environment in CBIT is for researchers. It is a place to challenge ideas and seek ground-breaking solutions. These are supplemented with the high-quality facilities, innovative thinking and friendly atmosphere which demonstrate CBIT a world-class institution.

Imperial College has been the place to develop and challenge myself in the ways that I cannot even imagine. I have worked in various areas during my PhD, which involved biomedical signal processing and system level design for removing baseline wander on the Electrocardiogram (ECG) while preserving the signal integrity. During these years, I developed a novel hardware efficient approach, which was implementable in a microcontroller with a low SNR system level design enabling continuous monitoring of the subject.

I have now left CBIT to pursue my post-doc studies in healthcare technology. I am currently working at Charing Cross Hospital with Prof. Adolfo Bronstein. The project involves small vessel disease (SVD) patients and investigates the dizziness the patient's experience. The research question focusses on whether the patients with these conditions express dizziness as a subconscious detection that the postural control mechanism is not right; or that they have become hypersensitive to the perception of their normal postural sway.



**NICOLETTA NICOLAOU,  
PhD**

The Centre for Bio-Inspired Technology (CBIT) at Imperial College London (ICL) was my home during my 2-year individual Marie-Sklodowska Curie fellowship (FP7, 2014–2016). My project, 'AnaeWARE', involved the collection and study of multi-modal activity (brain and cardiovascular signals) during anaesthesia to investigate how anaesthetics affect the human body. Such information is useful for patient monitoring during surgery and could provide an objective means of preventing intra-operative awareness or over-administration of anaesthetic agents.

The multi-disciplinary and friendly environment of CBIT made those 2 years very successful in terms of my career and, at the same time, highly enjoyable. At CBIT I was integrated into a first-class research team led by Timothy Constantinou. Formal and casual discussions with the team members, as well as with other researchers in CBIT, cultivated a strong sense of team-work and encouraged exchange of ideas. CBIT's highly multi-disciplinary environment provided excellent support for conducting research, forming new collaborations across Imperial College and developing new skills (both professional and personal).

My time at CBIT has opened up new doors for my career. Over the last year I have been working at the Brain Embodiment Laboratory at the University of Reading, investigating the use of a Brain-Computer Interface for modifying the user's emotional state via music. Despite the change of location, I still remain an Honorary Research Fellow at ICL and have been collaborating with medical doctors at Imperial College NHS Trust. Together with current and past collaborators, we are looking forward to progressing the field of anaesthesia monitoring through a closed-loop system for anaesthetic administration.

I am very lucky and thankful to have had the opportunity to work at CBIT and I look forward to using all the skills I have gained to progress on to the next stage of my academic career.



**Our mission:** Inspired by lifestyle aspirations and biological systems, the Centre for Bio-Inspired Technology is inventing, developing and demonstrating devices to meet global challenges in engineering, science and healthcare, by effectively and efficiently mimicking living systems to create innovative and advanced technologies.

## Research strategy

---

The Centre's research programme involves a strong combination of integrated miniature sensing with biologically-inspired, intelligent processing, through state-of-the-art semiconductor technology. We aim to make small healthcare devices, which combine electronics with biological processes. By applying conventional silicon microchip technology in new ways, we are creating new opportunities for medical device innovation.

We have pioneered next generation semiconductor sequencing (spun out and licensed internationally), developed and trialed the world's first biologically-inspired artificial pancreas for Type-1 diabetes, invented and commercialized the disposable digital plaster for healthcare monitoring (now both FDA-approved and CE-marked), and are continuing to push the envelope of how semiconductor technology is applied to biomedicine.

Such advances mean that there can be a shift in care away from a centralized model that puts the physician at its core to a smarter, more decentralized approach centred on the patient – known as personalised healthcare. They also open up new ways of coping with the huge problems of ageing populations and surges in chronic ailments such as diabetes and heart disease.

In our Centre, building a solid foundation for technological innovation through workbench engineering and fundamental scientific research is integral to our approach. Advancements at this level are crucial, not only for the enhancement and application of existing technologies and materials, but also for the discovery of new and disruptive alternatives. Research efforts at the preclinical stage then filter through to positive clinical outcomes with an agility only possible from the integrated development process found in CBIT. Innovations also flow both ways with the development of our novel technologies equipping scientists and engineers with new tools to address research questions of fundamental importance.

Researchers within the Centre for Bio-Inspired Technology also work together with other scientists and engineers from across Imperial College as well as in collaboration with partner institutions and industry. Project teams include medical researchers and clinicians to ensure the focus remains on the medical needs we aim to address. The Centre's Research Strategy is based on applying engineering technologies in innovative ways to provide personalised healthcare devices for chronic disease management. Our key activities are organized into five application-aligned technology themes: Genetic, Metabolic, Neural, Cancer, and Bio-modelling.



# Genetic technology

Research focuses on the development of semiconductor based fully integrated Lab-on-Chip platforms for detection of genetic markers in applications ranging from rapid diagnostics to on-the-spot genetic testing

[www.imperial.ac.uk/bio-inspired-technology/research/genetic](http://www.imperial.ac.uk/bio-inspired-technology/research/genetic)

## HEAD OF RESEARCH

**Professor Chris Toumazou FRS, FREng, FMedSci**

Infection, Cancer, Kidney disease and infertility, are examples of medical conditions where prevention, control, early detection and continuous monitoring have become the primary goals for the creation of a more evidence-based disease management model of healthcare. The fast growing information gained from molecular and clinical research on the identification and mapping of major genetic and epigenetic targets has provided insight on their role in susceptibility of disease and has led to a deeper understanding of their diagnostic, predictive and prognostic significance. Additionally, advances in diagnostic testing, genotyping, sequencing and the development of new technologies for Point-of-Care testing, are creating a paradigm-shift in modern medicine practices, ranging from the translation of technology innovations for emerging clinical applications towards the realization of a more affordable and stratified clinical model. Current methods for detection of genetic markers are mainly optical-based, are dependent on the use of fluorescent labels and of complex sample processing steps for isolation and discrimination of DNA sequences, therefore are difficult to scale. They are also mainly based on central laboratory facilities, with tests performed by skilled personnel and are of high cost. Given the needs for simplicity, low cost, speed, scalability and intelligence, genetic testing can now be simplified to lab-free, fast sample-to-result tests with the use of semiconductor technology, which allows for the integration of sensors, intelligent circuitry, signal processing and microfluidics, all in a single fullyintegrated scalable platform.

Our group has demonstrated that semiconductor technology can enable label-free, non-optical, real-time simultaneous amplification and detection of genetic targets using chemically sensitive transistors, also known as ISFETs (Ion-Sensitive Field-Effect Transistors), silicon chip-based chemical sensors traditionally utilised for measuring changes in ionic concentrations in solutions. Our group's expertise of over a decade in design and fabrication of robust chemical sensor arrays combined with microelectronics in CMOS integrating analog/digital circuitry, has resulted in numerous Lab-on-Chip platforms developed. Specifically in the area of diagnostics and disease prevention, where the emergence of smart sensory systems is evident, the

capability for these integrated platforms to perform intelligent sensing and actuation would improve significantly the speed for decision making at the point of need, delivering fast and on-the-spot results for detection of any target nucleic acid sequences in either DNA or RNA as well as nucleotide insertions.

This technology has been successfully commercialized through one of our spinout companies, DNA Electronics, to create next generation technology for on-chip sequencing and sample analysis. Applications in the Centre are ranging from fast genetic analysis of infectious targets (bacteria/ viruses) for rapid and controlled deployment of antibiotics and prevention of antimicrobial resistance – Infection Technology, to early screening of cancer markers and monitoring of progression targeting the personalisation of cancer treatment – Cancer Technology. Furthering the application of genetic technology in medicine, our research also focuses on the role of epigenetic markers and specifically the role of DNA methylation in prediction and monitoring of disease. DNA methylation is a widely applied epigenetic biomarker, a chemical tag that can modify the genetic function and regulatory mechanisms of gene expression. It has been extensively applied in the field of cancer with previous work at the Centre to have led in the development of an ISFET based pH-mediated Lab-on-Chip platform for detection of DNA methylation ratio in well-studied cancer markers.

The same technology is also applied in chronic kidney disease (CKD) management, a condition resulting from chronic kidney damage and prolonged renal dysfunction, often leading to renal replacement therapy. Focusing on methods for microRNA quantification and DNA methylation detection, we are developing a detection system that could aid developments in related epigenetic therapy for typically irreversible kidney damage, preventing the need for dialysis and renal transplantation.

The ISFET based technology is also being applied in a new field in the group, that of reproductive medicine and specifically of infertility, aiming for the development of a novel diagnostic sample-to-result test for detection of human male infertility acting as a prognostic tool for any Assisted Reproductive Technology (ART) laboratory, based on the analysis of DNA methylation marks in human sperm samples through the use of isothermal nucleic acid chemistries.

# Metabolic technology

Research on developing technologies for diagnosis and therapy of metabolic disease with the main focus on treating diabetes and its complications

[www.imperial.ac.uk/bio-inspired-technology/research/metabolic](http://www.imperial.ac.uk/bio-inspired-technology/research/metabolic)

## HEAD OF RESEARCH

**Dr Pantelis Georgiou**

Recent trends in daily lifestyle and poor diet have led to an increase in metabolic disorders which are affecting millions of people worldwide. A metabolic disorder develops when organs responsible for regulating metabolism fail to carry out their operation. Diabetes mellitus, currently the most severe metabolic disease and the leading cause of mortality and morbidity in the developed world, is caused by an absolute, or relative, lack of the hormone insulin which is responsible for homeostasis of glucose concentrations. Insulin deficiency leads to elevated glucose concentrations which, in turn, cause organ damage including retinopathy leading to blindness, nephropathy leading to kidney failure and neuropathy which is irreversible nerve damage. At least 3% of the world's population today is diagnosed with diabetes and this number is doubling every 15 years.

Our research in the Metabolic Technology Lab is focused on innovating state-of-the-art technology for the prevention and management of diabetes.

## CURRENT RESEARCH INCLUDES:

**The Bio-inspired Artificial Pancreas** – a fully automated closed-loop system, which mimics the functionality of a healthy pancreas. The core of the system contains a silicon integrated circuit, which behaves in the same way as biological alpha and beta cells of the pancreas. In doing so, it aims to offer more physiological control to subjects with type 1 diabetes, using insulin to control hyperglycaemic events and glucagon to prevent hypoglycaemia.

We have successfully validated the Bio-inspired Artificial Pancreas in adult participants with type 1 diabetes acquiring over 1000 hours of clinical data with the system, and proving its safety and efficacy. Our results to date have proven the safety and efficacy of the device and we have been granted approval to begin a pivotal trial on type 1 diabetic subjects in their home environment which will commence in December 2017.

**Decision Support Systems for Diabetes management** – an integrated system of wireless sensors (glucose, heart rate and motion), artificial intelligence algorithms and smartphone technology to optimise diabetes management. Ongoing projects include:

- **ABC4D (Advanced Bolus Calculator for Diabetes)** – This research project in collaboration with DEXCOM uses continuous glucose monitoring and

Case-Based Reasoning to create an adaptive bolus calculator for optimal insulin dosing recommendation. Our smart-phone based ABC4D system has undergone clinical trials in a safety and feasibility study including 10 people with Type 1 diabetes over six-weeks, as well as a randomised controlled long-term study with 20 participants over a six-month period.

- **PEPPER (Patient empowerment through Predictive PeRsonalised decision support)** – PEPPER is a EU-funded project (H2020) involving two partners from industry (Cellnovo, Romsoft) and four partners from academia (Oxford Brookes, University of Girona, IDiBiG, Imperial College). It includes development of CBR to personalise insulin and carbohydrate recommendations. In addition, there is a strong emphasis on safety, with glucose predictive glucose alarms, predictive basal insulin suspension, meal insulin constraints and fault detection. Feasibility trials (n=15) are currently underway.

**ARISES (An Adaptive, Real-time, Intelligent System to Enhance Self-care of chronic disease)** – This an EPSRC funded research project looking to develop Machine Learning algorithms running locally on a smartphone and use common wearable technology to quantify the lifestyle of someone with diabetes and optimise their diabetes control through insulin and carbohydrate recommendation and education. A specific focus is on optimisation of usability through human centred design and modification of behaviour, in addition to classifying patient state such as stress, illness and exercise through the use of wearable technology.

**Sensory systems for continuous monitoring of metabolites and diagnostics** – which includes devices which fully integrate chemical sensors and low-power processing algorithms to provide cheap, disposable and intelligent chemical monitoring systems with long battery lifetimes. These are currently being used to make reliable and robust continuous glucose sensors by integrating glucose sensing micro-spikes with CMOS technology.

**Metabolic Algorithms and Models** – which includes developing in silico models describing the interaction between glucose, insulin, glucagon, the nervous system, and other metabolites within the body to allow reliable simulation and validation of algorithms used for diabetes management. We also develop fault detection systems to account for glucose sensor and insulin pump failures and variability within our closed-loop system.



# Neural technology

Innovating neurotechnologies to enable new capabilities in scientific research, and medical devices to improve medical care and quality of life for individuals with neurological conditions

[www.imperial.ac.uk/neural-interfaces](http://www.imperial.ac.uk/neural-interfaces)

## HEAD OF RESEARCH

### Dr Timothy Constandinou

We are now entering a tremendously exciting phase in our quest to understand the human brain. With large-scale programmes like the US Presidential BRAIN Initiative, EU Human Brain Project, Japanese/MINDS, China Brain Project, etc, there is currently a huge appetite for new neurotechnologies. There is also, more recently a concerted effort (e.g. Galvani Bioelectronics, NIH SPARC) on electroceuticals – bioelectronic devices that target individual nerve fibres within the peripheral nervous system to treat an array of conditions.

We have already witnessed the impact made by devices such as cochlear implants and deep brain stimulators, with hundreds of thousands of individuals that have and are benefitting every day. Soon, similar assistive technology will emerge for the blind, those suffering from epilepsy, and many others. Electroceuticals will furthermore provide targeted therapy to a range of conditions that have not normally been associated with the nervous system. These could range from allergies, migraines, asthma and obesity all the way up to hypertension, infertility and possibly even cancer.

With the current capability in microtechnology, never before have there been so many opportunities to develop advanced devices that effectively interface with the nervous system. Such devices are often referred to as neural interfaces, or brain-machine interfaces, and range from wearable systems to fully implantable devices. Neural prostheses use such interfaces to bypass dysfunctional pathways in the nervous system, by applying electronics to replace lost function.

Our research at the Centre for Bio-Inspired Technology (CBIT) and Next Generation Neural Interfaces (NGNI) lab is aimed, ultimately at developing such assistive technology by exploiting the integration capability and scalability of modern semiconductor technology.

## MAIN PROJECTS

**CANDO (Controlling Abnormal Network Dynamics using Optogenetics)** – A world-class, multi-site, cross-disciplinary project to develop a cortical implant for optogenetic neural control. Over seven years the project will progress through several phases. Initial phases focus on technology design and development, followed by rigorous testing of performance and safety. The aim is to create a first-in-human-trial in the

seventh year in patients with focal epilepsy. In collaboration with Newcastle University, UCL and Newcastle Hospitals NHS Foundation Trust. Funded by the Wellcome Trust and EPSRC.

[www.cando.ac.uk](http://www.cando.ac.uk)

**ENGINI (Empowering Next Generation Implantable Neural Interfaces)** – Neural interfaces will in the future need to observe the activity of thousands of neurons. This will improve the effectiveness of neural decoding strategies by increasing the information transfer rate. The availability of such a technology would be a true game changer, enabling new scientific and prosthetic applications. Our vision is that to achieve this, neural interfaces need to be distributed across multiple devices, each being autonomous and fully wireless. ENGINI is developing a new breed of mm-scale neural microsystems that directly tackle the grand challenges of long term stability, energy efficiency, and scalability. Funded by the EPSRC.

[www.imperial.ac.uk/neural-interfaces/research/projects/engini/](http://www.imperial.ac.uk/neural-interfaces/research/projects/engini/)

### **I2MOVE (Intelligent implantable modulator of Vagus nerve function for treatment of obesity)** –

The i2MOVE project is about tackling obesity. In this project, we are designing a bio-inspired implant that will serve as a novel treatment for obesity. This targets the vagus nerve which transmits information between the gut and the brain. By stimulating the vagus nerve with electrical impulses, the implant will mimic the natural satiety signals produced after a meal, providing the patient with a means of appetite control. Funded by the ERC.

[www.imperial.ac.uk/a-z-research/i2move/](http://www.imperial.ac.uk/a-z-research/i2move/)

**SenseBack (Enabling Technologies for Sensory Feedback in Next-Generation Assistive Devices)** – The goal of this project is to develop technologies that will enable the next generation of assistive devices to provide truly natural control through enhanced sensory feedback. To enable this level of feedback, we must meet two clear objectives: to generate artificial signals that mimic those of the natural arm and hand, and to provide a means of delivering those signals to the nervous system of a prosthesis user. In collaboration with the Universities of Newcastle, Southampton, Essex, Keele, Leeds. Funded by the EPSRC.

[www.senseback.com](http://www.senseback.com)

For a complete list of all ongoing research projects please visit: [www.imperial.ac.uk/neural-interfaces/research/projects](http://www.imperial.ac.uk/neural-interfaces/research/projects)



# Cancer technology

Development of cancer diagnostic sample-to-result microchip based prototypes that will assist in risk stratification and optimization of cancer treatment at the early and advanced diagnostic stage

[www.imperial.ac.uk/bio-inspired-technology/research/cancer-technology](http://www.imperial.ac.uk/bio-inspired-technology/research/cancer-technology)

## HEAD OF RESEARCH

### Professor Christofer Toumazou

Our research at the Centre for Bio-Inspired Technology is focused on the application of microchip based sensing technologies for early screening, detection and monitoring of cancer markers, with the ultimate goal being the development of systems assisting at the point of need aiming for the personalization of cancer therapy. Primary focus is on the areas of:

**Early detection and therapeutic monitoring of breast cancer** – Although surgery is capable of removing the primary cancer, in many patients, cancer cells can seed throughout the body forming micrometastases, not detectable through screening tests. Detecting early the presence of micrometastases before relapse occurs is of great importance as it will allow treatment to be tailored to the patients' clinical profile. To date, a number of lab-based tests have been developed, primarily for diagnostic purposes, requiring tissue biopsies which are often difficult to obtain and may not be fully representative of the disease due to its inherent intratumoral heterogeneity, or are focusing on NGS methods, which are of high cost and require processing power to analyse genome-wide sequencing data. In contrast, a blood based test or 'liquid biopsy' has the potential to detect tumour specific genetic markers found in blood circulation, in a minimally invasive way. Such test could predict the risk of relapse and could be repeated over the course of treatment to monitor drug response and disease progression. This would enable the realization of a more 'curative', well-stratified, patient-centric therapy model. This project is in collaboration with Prof Charles Coombes (Department of Surgery and Cancer, Imperial College London) and Prof Jacqui Shaw (Department of Cancer Studies, University of Leicester). Our research in the Centre involves the development of a microchip-based, sample-to-result, scalable Lab-on-Chip system consisting of arrays of ISFET sensors, which in combination with microelectronics and information processing units will provide a fast and of low-cost solution for early detection of recurrence through precision screening and therapeutic monitoring of the disease.

### Breath analysis for oesophago-gastric

**cancer detection** – Only 35% of patients with oesophago-gastric (OG) cancer are currently treated with curative intent, whereas 15% of those operable have Stage I cancer. The five-year survival for oesophageal and gastric cancer is 13% and 18% respectively in the UK, among the worst in Europe, demonstrating the clinical consequences of this diagnostic challenge. Our ultimate goal is to develop a hand-held, Point-of-Care device that can detect and analyse Volatile Organic Components (VOCs) in breath, to evaluate the risk of oesophago-gastric cancer and suggest the need for further endoscopic investigation. This project is part of an ongoing collaboration with Prof George Hanna from St Mary's Hospital and his group, world leading experts in breathomics for OG cancer. A series of studies have been conducted, which have identified statistically significant differences in the concentration of twelve VOCs from three chemical groups (aldehydes, fatty acids and phenols) from the exhaled breath of patients with OG cancer compared to a control group. Our research involves the development of a prototype for VOC breath profiling, providing information necessary to determine and quantify the risk of OG cancer. Diagnostic recommendation will be determined using an information theory based machine learning algorithm developed in our group by Dr Nikolic and his research team.

### Enhancing chemotherapy through vagal nerve

**stimulation** – Denervation of the stomach has been shown to greatly improve the outcomes of patients with gastric cancer. In the past, this has been achieved by performing a vagotomy, whereby the vagus nerve is cut at the stomach. However, this has a number of side-effects which can permanently deteriorate the quality of life of the patient. Recently, we have begun the preparation for a clinical trial that will use electrical stimulation to block the vagus nerve during chemotherapy. If successful, we will be able to show that we can achieve the same improvement in patient outcomes as seen with a vagotomy, whilst leaving the vagus nerve intact, and therefore maintain the quality of life of the patient. The trial will be led by Prof. George Hanna, in collaboration with the i2MOVE group at the Centre for Bio-Inspired Technology, and Enteromedics, USA.



# Bio-modelling

We develop methods and computational tools for understanding, modelling and simulating various biological and physiological processes and their applications in bio-inspired electronic systems

[www.imperial.ac.uk/bio-modelling](http://www.imperial.ac.uk/bio-modelling)

## HEAD OF RESEARCH

**Dr Konstantin Nikolic**

Understanding the fundamental principles of information coding and processing of living organisms and applications to diagnostics and medical treatments, machine learning and bio-inspired systems.

Some of our recent projects include:

**Computational Optogenetics** – We have been contributing to the leading research in the rapidly expanding field of optogenetics by developing enabling technologies: first establishing the photo-cycle models for opsins, then models of neurons/neural networks expressing them, and finally designing light sources and illumination protocols to achieve desirable response or modulation of activity. The models have been used by many groups worldwide for various applications: creating new variants of opsins with different kinetics, understanding experimental results, predicting/explaining new effects, designing illumination protocols and devices, etc.

Multi-scale tools, open access cloud computing portal: In order to characterise, understand and apply various rhodopsins, we have developed an integrated suite of open-source, multi-scale computational tools called PyRhO. The module is written in Python with an additional IPython/Jupyter notebook based GUI, allowing models to be fit, simulations to be run and results to be shared through simply interacting with a webpage. We offer PyRhO on a web-site, with all installations and modules already in place so that user can immediately start benefiting from it: portal Prometheus <http://try.projectpyrho.org> This is a unique portal for running virtual experiments in neuroscience and physiology of excitable cells in general, which includes the two most popular platforms for detailed neural simulation (NEURON) and neural network simulations (Brian). Users do not need any more to download and install all these very useful but still technically demanding simulation softwares. With our GUI which offers simple setup of the ion-channels and cell parameters as well as stimulation protocols together with output visualization it is a great tool for both educational and research purposes.

## Computational Neuroscience – Peripheral nerves

– Our team showed for the first time both theoretically and experimentally that focused infrared light can selectively and transiently block specific nerves in a

nerve bundle. This work was a breakthrough in understanding the heat effects on peripheral nerve function. Subsequently several groups confirmed our findings and new field of using IR laser light for modulating electrical activity of excitable cells have been created.

## Machine Learning for Biological Systems and Healthcare

– A number of machine learning algorithms have been developed at CBIT for non-invasive diagnostics, hospital expert systems, diabetes decision support systems, etc. The aim of this research is to empower clinicians in diagnosis and management of various health conditions. For example, we developed a machine-learning algorithm which could indicate oesophago-gastric cancer on the basis of breath analysis (breathomics).

**Modelling of cell signalling cascades** – G-protein coupled cascade (GPCC) and TRP ion channels are the key physiological components in the cell sensory and communication processes. They play a vital role in human physiology and represent a major new target for pharmaceutical industry. We have developed a comprehensive stochastic model of the GPCC including TRP kinetics, which improved our understanding of this crucial mechanism. Many interesting properties have been revealed as well as the underlying mechanisms by which the system generates high quantum efficiency, huge signal amplification and fast recovery. Utilized by leading groups in the neuromorphic design community, this work was one of the pioneering in the field of cytomorphic design in analogue electronics.

**Modelling of the Retinal neural circuitry** – We have solved the problem of the retina information processing and created a predictive algorithm for the retina response to various visual inputs. We first introduce a new technique of deriving receptive field vectors (RFVs) that utilises a modified form of mutual information (“Quadratic Mutual Information”). We probed the high dimensional space formed by the visual input for a much smaller dimensional subspace of RFVs that give the most information about the response of each cell. The new technique is very efficient and fast and now we are implementing it on other ‘small data’ problems, for example when the input information is limited (e.g. clinical trials), but high-dimensional.

The code for some of these projects can be found in our GitHub repositories: <https://github.com/bio-modelling>

# Research funding

We are grateful to receive funding from government, the EU, charities, donors and industry. Our current portfolio includes the following:

Project	Sponsor	Start Date	Duration
Novel Angioplasty Catheter	MRC	October 2017	3 years
Paediatric TB diagnostics using host response	NIHR	December 2016	4 years
ARISES	EPSRC	December 2016	3 years
PEPPER	Commission of the European Communities (EU)	February 2016	3 years
Fully autonomous integrated circuit to readout and auto-calibrate multi-target arrays (AutoIC)	Imperial College London	December 2015	3 years
EMBRACE	EPSRC	August 2015	2 years
Empowering Implantable Next Generation Neural Interfaces	EPSRC	August 2015	5 years
i4i EPOC IMPACT	NIHR	August 2015	3 years
Disruptive Semiconductor Technologies for Advanced Healthcare System	EPSRC	August 2015	5 years
Enabling technologies for sensory feedback in next-generation assistive devices	EPSRC	March 2015	3.5 years
Controlling Abnormal Network Dynamics with Optogenetics (CANDO)	Wellcome Trust / EPSRC	August 2014	7 years
An Intelligent and Implantable Modulator of Vagus Nerve Function Treatment of Obesity	Commission of the European Communities (EU)	April 2013	5.5 years
A Bio-Inspired Artificial Pancreas for Control of Type 1 Diabetes in the Home	Wellcome Trust	September 2011	8 years

# Featured research

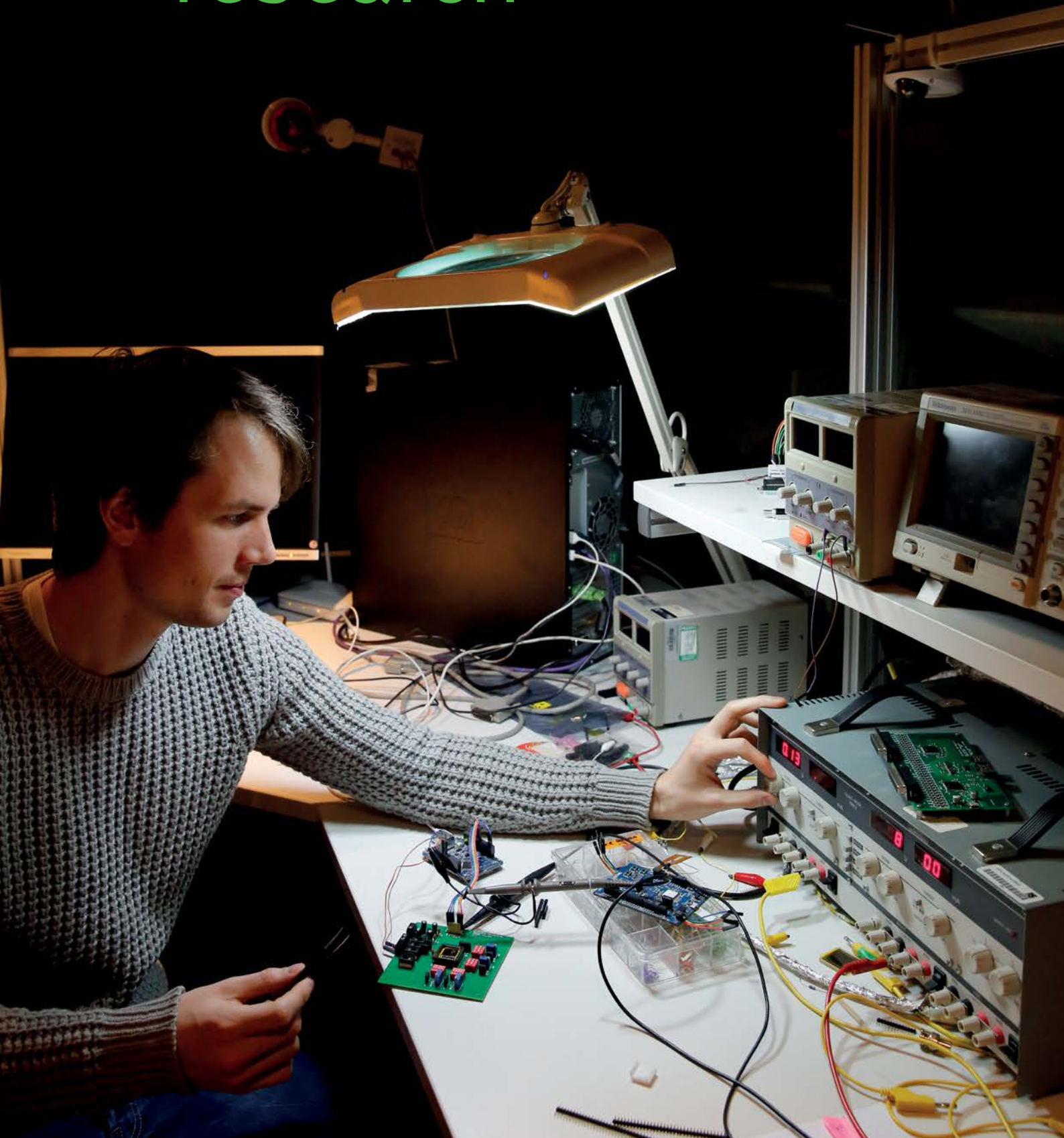

# Neural technology: tools and resources for neuroscience

Dr Ian Williams, Dr Song Luan, Dr Yan Liu, Dr Timothy Constandinou

Over the past decade, our research projects have developed new software methods, and multiple generations of different integrated circuit designs and hardware platforms for neural interfacing. We always endeavour, wherever possible to disseminate and make such resources available to the wider research community, either directly or in collaboration with industry partners.

We have, in particular over the past 12 months (supported by two EPSRC Impact Accelerator Awards) placed significant effort in translating our research to methods and materials suitable for community exploitation. Details of such resources are and will be available through our web portal: [www.imperial.ac.uk/neural-interfaces/resources](http://www.imperial.ac.uk/neural-interfaces/resources)

In this feature, we briefly describe two hardware resources that we are in the process making available.

## APPLICATION SPECIFIC ICS FOR NEURAL INTERFACING

Electrophysiology (ePhys) is the study of the electrical properties of biological cells and tissues, involving measuring voltage changes or electric currents. In neuroscience, it includes measurements of the electrical activity of neurons and, particularly, action potential activity. Electrical Stimulation uses electrodes to apply a potential gradient across a neuron causing intracellular ionic current flow and localized depolarization and hyperpolarization of the cell membrane that results in neural stimulation.

We have developed a range of Application Specific Integrated Circuits (ASICs) to facilitate ultra-low power multi-channel neural recording and stimulation in a compact form factor (<0.5mm<sup>2</sup> per channel).

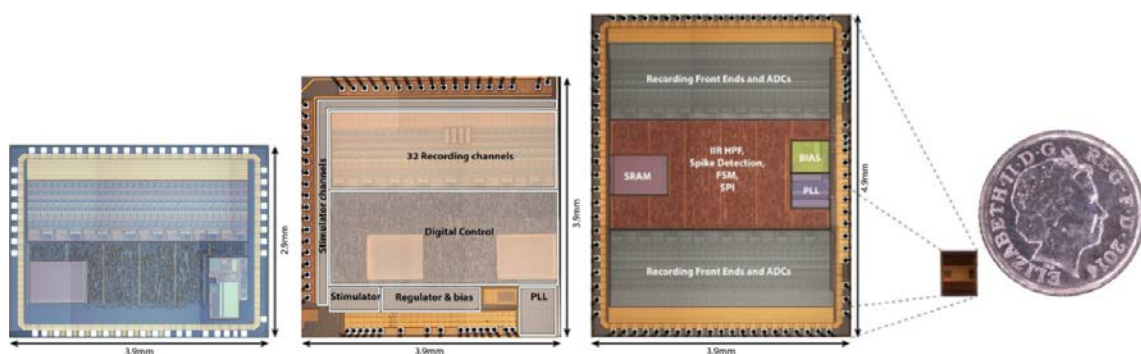

Neural interfacing integrated circuit designs developed as part of NGNI, iPROBE and SenseBack projects. Shown are: (A) NGNI<sub>32</sub> neural recording ASIC, (B) SenseBack<sub>32</sub> neural recording/stimulation ASIC; (C) NGNI<sub>64</sub> neural recording ASIC with a 5p coin for scale.

FEATURES	APPLICATIONS
<ul style="list-style-type: none"> <li>• 64/32-channel neural recording system on a chip</li> <li>• Low input referred noise 2.2µVrms/Channel</li> <li>• Integrated 3rd order tunable bandpass filter 0.1Hz–7kHz</li> <li>• Configurable input range from ±400µV to ±10mV</li> <li>• Configurable gain from 180 to 4500</li> <li>• On-Chip ADC, 10-bit resolution (LSB configurable between 0.4µV and 25µV)</li> <li>• Tunable sampling rate up to 21kHz</li> <li>• Low current consumption (2mA) with all channels active</li> <li>• Channels individually tunable for different electrophysiological signals with different bandwidth and gain setting</li> <li>• Thresholding and windowing (e.g. for spike detection) with low data rate event driven snippet output</li> <li>• SPI output for interfacing with embedded controllers (&lt;1ms latency for snippet results)</li> </ul>	<ul style="list-style-type: none"> <li>• Signal acquisition for electrophysiology systems</li> <li>• Large scale recording applications (multi-probe, multi-channel)</li> <li>• Low noise instrumentation system</li> <li>• Closed loop low-latency biofeedback</li> </ul>

## SCALABLE NEURAL RECORDING INTERFACE WITH REAL-TIME SPIKE SORTING



NGNIv1 hardware spike sorting headstage. Shown are: USB3.0 SuperSpeed bridge (top left); 32-channel spike sorting headstage (top centre); and software environment for configuration and real-time visualization (top right); controller with MicroSD logger (bottom left); and standalone configuration for chronic recordings (bottom right).

Spike Sorting is the process of de-interleaving a recorded neural signal (that observes extracellular action potentials) in order to determine the firing patterns of individual neurons from the aggregate spike stream.

The NGNI platform is an end-to-end solution for on-node, real-time spike sorting. By using a compact,

onboard (template based) spike sorting engine, together with offline training (WaveClus-based), a low power real-time solution is achievable.

### FURTHER DETAILS:

[www.imperial.ac.uk/neural-interfaces/resources/spike-sorting-platform](http://www.imperial.ac.uk/neural-interfaces/resources/spike-sorting-platform)

FEATURES	APPLICATIONS
<ul style="list-style-type: none"> <li>• 32-channel neural recording/streaming</li> <li>• On-node, realtime template-based spike sorting</li> <li>• Proprietary template building engine (based on WaveClus)</li> <li>• Onboard template memory, 18.4kbit (4 templates per channel)</li> <li>• Low latency (0.3ms) SPI output</li> <li>• Low output data-rate – suitable for wireless communication</li> <li>• MicroSD logging and control module for standalone deployment (no PC or tether required)</li> </ul>	<ul style="list-style-type: none"> <li>• Signal acquisition systems for electrophysiology</li> <li>• Large-scale recording applications (multi-probe, multi-channel)</li> <li>• Realtime brain machine interface applications</li> <li>• Closed loop low-latency biofeedback</li> </ul>

# Ultra-wideband radar-on-chip for medical imaging and biosensing

Timo Lanteslager, Elliott Schires, Dr Pantelis Georgiou, Mathias Tømmer (UiO), Professor Tor Sverre Lande (UiO), Dr Timothy Constandinou

Non-invasive medical imaging techniques are of paramount importance for diagnosis of diseases and evaluation of treatments. Current technologies that are being used for imaging of soft tissues can deliver images of the internal structure of our body with astonishing resolution. However, the lack of mobility, low temporal resolution and enormous cost remain a problem. Especially considering our ageing population and ever-rising healthcare costs, it is of vital importance to explore alternative imaging techniques.

## MICROWAVE IMAGING

One technology that has exciting potential for use on a large scale is microwave imaging (MWI). MWI uses electromagnetic waves in the microwave frequency band for sensing and imaging. Microwave radiation is non-ionizing, and safe to use at low power levels, but penetrates biological tissue relatively well. Because of dielectric contrasts between different tissues in the body, it is possible to image the body's internal structure using either radar-based imaging or tomographic imaging techniques.

Pulsed ultra-wideband (UWB) radar is particularly useful for detecting small variations inside the body. Because a gaussian modulated sine wave is used as an excitation signal, both time-of-flight based ranging and interferometric radar techniques can be applied. Recent technological advances have made UWB radar low power, mobile and cost-effective: The Norwegian company Novelda AS has developed a UWB radar-on-chip with 3.8GHz centre frequency and 2.5GHz bandwidth.

*Characterization of body-coupled antennas in phantom liquid. The radiation pattern is acquired by measuring energy transmission from different angles in a fluid that mimics the human body (below left). UWB pulse transmission in the phantom is measured to study pulse propagation in dispersive media such as the human body (below right).*

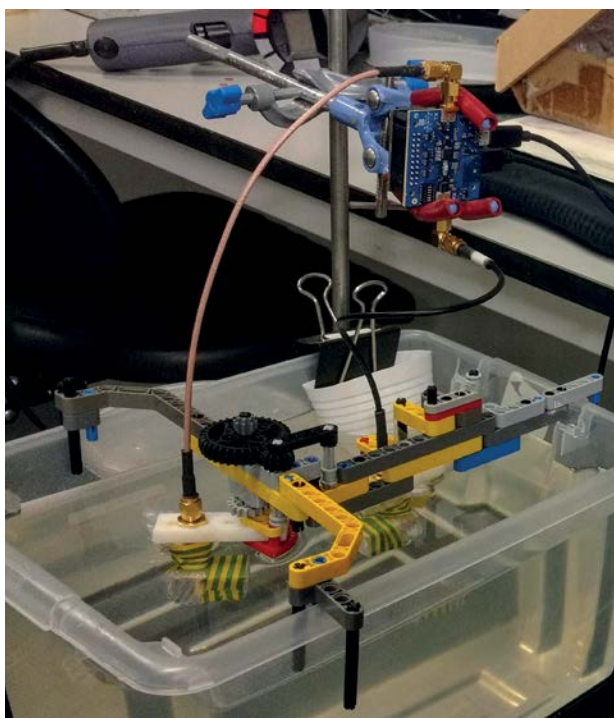

## THIS PROJECT

In the current project we collaborate with University of Oslo and Novelda AS, both located in Norway, to use pulsed UWB radar-on-chip for medical imaging and biosensing. Radar-on-chip technology provides us with an imaging speed that exceeds traditional MWI systems, as well as other imaging modalities such as MRI. This makes it suitable for imaging moving structures, and we therefore focus our research mainly on the respiratory, cardiovascular and cerebrovascular system.

## IMAGING OF THE BRAIN

Due to dielectric contrast between blood tissue and brain tissue, it is possible to detect volumes of blood inside the human brain using radar. This is extremely interesting for stroke detection: a pre-hospital assessment could be made using a portable MWI system to differentiate between ischaemic and haemorrhagic stroke. On the long term, MWI could even be used for functional neuroimaging, for example in a brain machine interface: local cerebral blood volume is an indicator for neuronal activity, which could be measured using a portable and highly affordable MWI system.

## VITAL SIGNS SENSING

In addition to imaging, radar devices can perform continuous vital sign monitoring with non-intrusive setups, through clothes or behind walls. By detecting and extracting body motion linked to physiological activity using UWB radar, accurate simultaneous estimations of both heart rate (HR) and respiration rate (RR) is possible. Currently used techniques to measure these rates rely on wearable sensors, electrodes or chest-straps. These standard methods can impair

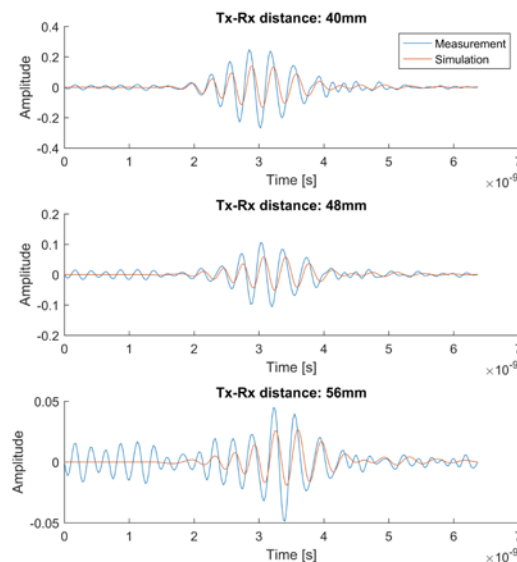



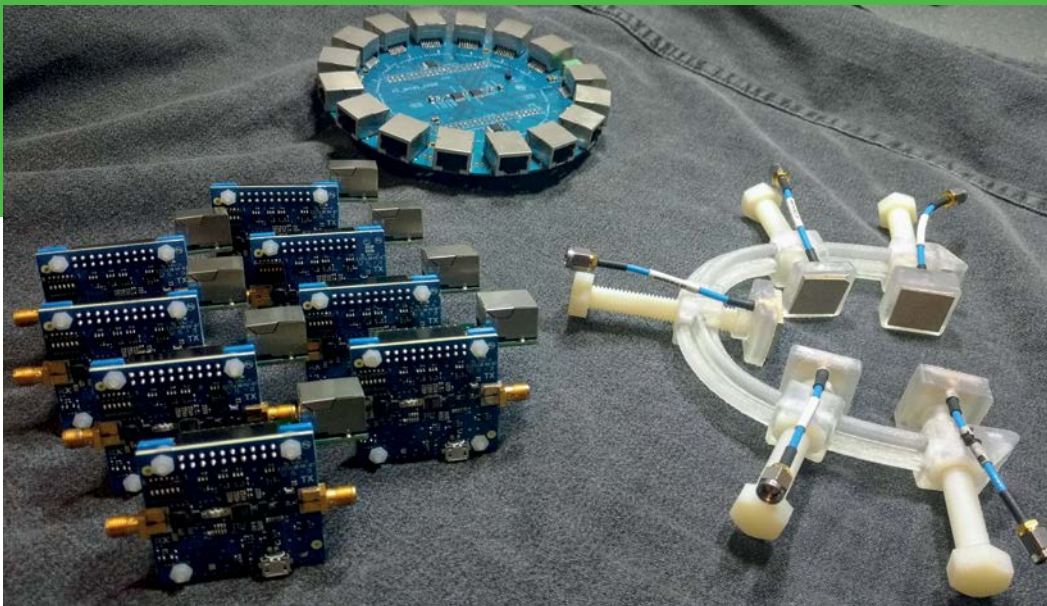

Multiple radar module setup. Eight UWB radar modules are shown that can be run simultaneously to perform 2D radar imaging. Also shown is a bracket containing 5 body-coupled antennas designed for arterial imaging in the upper arm.

movements if wired, often require direct contact with skin, and may not be comfortable for younger patients or for chronic monitoring. A non-invasive technique for HR and RR estimation without the need of wearable sensors enables the implementation of a sensing platform to perform with ease the chronic measurement of vital signs, ultimately allowing healthcare and well-being monitoring over time.

Most research to date has focused on front monitoring with a radar of superficial motion of the chest due to the pumping action of the heart and respiration. Our approach is to perform body penetration of electromagnetic energy to allow back monitoring of human subjects. In this way, continuous time signals of cardiorespiratory activity can be generated based on the actual motion of organs, with several radar modules embedded in seats, wheelchairs or mattresses.

### CURRENT CHALLENGES

Due to the conductive nature of biological tissue, signal attenuation is a huge challenge in MWI and vital sign sensing. Increasing power is not the answer, as harmful tissue heating needs to be avoided. Using lower frequencies of electromagnetic radiation improves tissue penetration, but there is a trade-off with spatial resolution. To overcome these challenges, we are constantly developing and evaluating new MWI

hardware, in collaboration with our partners. Besides the development of a multistatic imaging rig, body-coupled antennas are being developed to maximise radiation efficiency and reduce reactive near-field absorption. Radar signal propagation through dispersive media is being measured in phantoms that mimic the properties of biological tissues, to characterise antennas and evaluate imaging hardware. Radar measurements are done both on phantoms to test beamforming and imaging algorithms, and on humans to sense and image cardiorespiratory activity in different parts of the body.

### FUTURE WORK

MWI has enormous potential as a medical imaging and sensing technique. The potential applications in industry for radar based health monitoring systems are numerous. With improvements in hardware, a variety of algorithms can be developed using this sensing platform to accomplish remote sleep monitoring, people identification, blood pressure or even glucose level estimation. Recent technological advances have made UWB radar low power, mobile and cost-effective. MWI is therefore a real opportunity for accessible, reliable and precise processing in an automated way, and could replace several medical imaging and sensing devices at reduced cost.

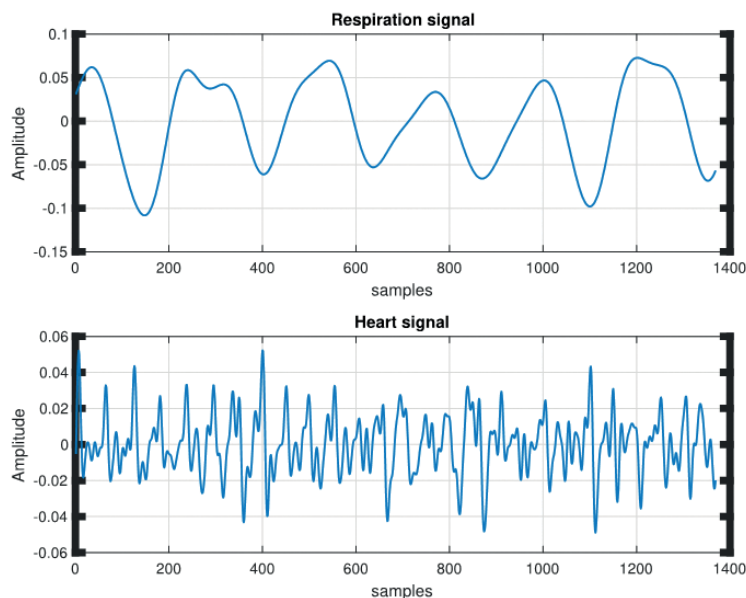

Overview of static radar measurements of heart and respiration motions (left) using a car seat equipped with a single UWB sensor located in the backrest (right)

# ARISES: An Adaptive, Real-time, Intelligent System to Enhance Self-care of chronic disease

Research Team: Dr Kezhi Li, John Daniels, Dr Chukwuma Uduku, Professor Robert Spence, Dr Nick Oliver, Dr Pau Herrero-Viñas and Dr Pantelis Georgiou

In the UK it is estimated that 15 million people have a long-term chronic disease and it is estimated that over the next 10 years this will result in the death of 5 million people. Self-management can help reduce this burden with increases in physical functioning, benefits in terms of greater confidence and reduced anxiety, reduction of unplanned hospital visits and improvement to adherence to treatment and medication.

One in seven people in the UK own wearable technologies. 76% of UK adults own a smartphone. The combination of wearable devices and smartphones is an already widely adopted technology and presents an opportunity to be used as a platform for self-management of lifestyle and chronic disease. One of the challenges here is the lack of adaptiveness which allows flexibility such that systems can cope with inter-subject and day-to-day variability in everyday life. Thus it is essential to have a full understanding of patient behaviour when designing a system that is intended to improve self-management.

ARISES is an EPSRC-funded project aiming to develop a novel mobile framework that is able to intelligently collect data from an individual and facilitate a timely intervention to manage chronic disease through therapeutic and life-style recommendation.

As an exemplar case to demonstrate the ARISES system we have chosen the management of type 1 diabetes. The system will promote the self-management of diabetes by optimizing glucose control through insulin dosage recommendation (therapeutic advice) and exercise and physical activity support (heart rate, skin temperature, ambient temperature, etc.), carbohydrate recommendation to prevent hypoglycaemia, and behavioral change through education (lifestyle advice). Recently continuous glucose monitors have also been linked to these applications and are able to provide real-time biological data to inform people with diabetes of their historical glucose trends.

In this work we will develop a case-based reasoning (CBR) and machine learning (ML) framework as an adaptive, real-time decision support system to run locally a smartphone without the need for an internet connection. A deep neural network (DNN) will be adopted in extracting essential features from our dataset; and long short-term memory (LSTM), a recurrent neural network (RNN) architecture will be leveraged to make the glucose time-series predictions and the hypoglycaemia/hyperglycaemia classifications. Patient safety systems will also be embedded within and security will be guaranteed by compliance to standards. The end-to-end solution will be optimised for power consumption to allow maximum use in a free-living environment.

A user interface will be designed that is intuitive and easy to use, which will be optimised by considering end-user requirements from the patient focus groups and usability pilot studies. With focus groups of patients with diabetes, a prototype user interface will be designed with standard HCI methods using feedback implemented on the wearable technology and smartphone. The interface will then be iteratively improved through monthly focus groups. The optimised visualization tool will be validated and final usability will be quantified by gathering patient feedback.

**Current progress:** An initial clinical trial has been set up to build a rich dataset of 12 patients over two six-week periods. This would provide insight into the primary factors affecting blood glucose variability, and the subsequently aid in the design of intelligent algorithms to determine periods of hypoglycaemia/hyperglycaemia that provides the needed intervention. Results from the trial intend to be used to derive various correlations, such as ambient temperature vs. glucose; day time vs. prandial glucose; carbohydrate, glycaemic index, protein, fat vs. prandial glucose; alcohol vs. glucose; aerobic/anaerobic exercise vs. glucose, over next 24 hours.

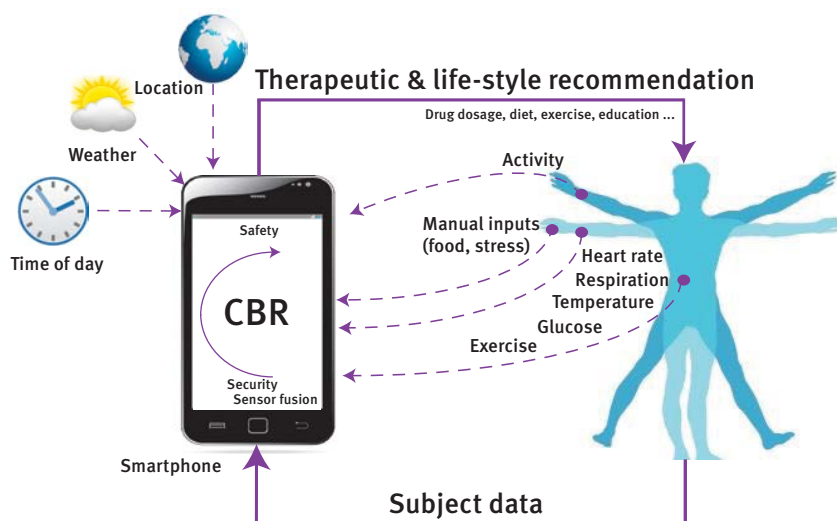

# Novel angioplasty catheter for treatment of calcified arteries

**Dr Reza Bahmanyar**

Funding: MRC DPFS (MR/Po26850/1), in partnership with the universities of Leicester and Sheffield

## BACKGROUND

Coronary artery disease is one of the commonest clinical conditions associated with high morbidity and mortality in developed countries. It is often treated by percutaneous coronary intervention (PCI), one of the most common therapeutic interventional procedures performed anywhere. Coronary calcification is an inherent element of atherosclerotic coronary disease and poses significant challenges to PCI procedures. Vascular mural calcification can prevent effective coronary dilation or lead to incomplete expansion of coronary stents. Extensive coronary calcification at present may preclude a PCI approach necessitating either open heart surgery or a palliative medical strategy. The number of procedures with coronary calcification is increasing as coronary intervention moves into an older population.

There are currently two technologies in use. These either have limited efficacy or require training in a unique complex skillset not familiar to the majority of operators. Scored or 'cutting' balloons are bulky and delivery into calcific lesions is frequently impossible. Rotational atherectomy or rotablation is a technology where a rotating diamond coated burr is introduced to disrupt coronary calcification. Rotablation is effective but requires specific training distinct from traditional PCI techniques. It is notable that although this technology has been available for many years, the proportion of trained operators remains low. Both methods are associated with increased complication rates due to vessel injury, dissection and perforation.

## PROJECT CONCEPT

It is known from elementary mechanics that impulses can produce a great amount of force over a short time interval. This is the functional principle that instruments like impact hammer work very well. It is also well known from fluid mechanics that incompressible fluids can be used as a medium for rapid and efficient power transmission. We have adapted these technologies to develop a catheterised device enabling localised endovascular therapy at a controlled depth and energy for disrupting the vascular calcium to facilitate subsequent PCI.

## PROGRESS TO DATE

We received proof of concept funding from MRC ICIC in 2015 and have prototyped a device capable of delivering impacts of variable frequency and energy to sites of calcification. Such impacts lead to micro-fractures in vascular mural calcification and subsequently enable traditional PCI balloon dilation and stenting techniques to proceed unhindered. The device consists of an impact pressure generating system connected to a saline filled catheter equipped with a micro-fabricated expandable impacting tip.



*Pressure generating unit*



*Expandable catheter tip*

The device is based on current over-the-wire catheterised coronary technologies familiar to Interventional Cardiologists to be used as an adjunctive device during PCI for the treatment of calcific coronary disease. Additionally an allied device concept has been designed to disrupt calcification at the proximal cap of coronary chronic total occlusions to aid antegrade wiring and PCI of these traditionally challenging anatomies.

We recently received funding from MRC for 3 years to further develop and optimise the system and perform pre-clinical studies.

# Two visiting professors share their views

The Centre has been fortunate to attract internationally noted researchers to spend time working with its staff and students and adding to the collaborative and entrepreneurial mix which is fundamental to its success. Here, two of its Visiting Professors give their views of the Centre and discuss the contribution the research is making to the future direction of healthcare.



**PROFESSOR ALYSSA APSEL**  
Cornell University

Ever since I began my career “experts” have been declaring the end of analog design. In the early 1990’s, the onslaught of digital integrated circuits caused many designers to insist that analog was dead (Analog Circuit Design,

Jim Williams, Newnes, 1991). Again in 2004 a panel of industry experts including Tony Bonaccio from IBM and Charlie Sodini from MIT declared that the inability to scale analog components was to further reduce the utility of analog design. While every obituary written for analog design has focused on the fact that traditional analog components do indeed scale poorly, technology scaling has yet to eliminate analog design. The predictions of the demise of analog have been dead wrong. Instead, analog design has changed into what would be called today “mixed signal design” and has seen a new and exciting resurgence. 70% of IC designs today are mixed-signal, and that figure is increasing. In a 2012 DesignCon panel, Navraj Nandra, director of marketing for Synopsys put it best saying, “Analog never disappeared... I think there is a very exciting new school of analog that’s a lot more interesting than some innovations in digital.”

It is my belief that the most exciting new opportunities for the future of mixed signal design lie in the vision of ubiquitous electronics that blend seamlessly into everyday life. Enabling these self-powered, autonomous systems requires discovery of new efficiencies and functionalities within an already very well understood platform of electronics. The only way that this will be possible is by reducing overdesign and exploiting system level efficiencies by blending analog and digital circuits. With this in mind, I will highlight a few areas of on-going and future research that best demonstrate my philosophy.

## ULTRA-LOW POWER RADIO NETWORKS – ENABLING COMMUNICATION AND INFORMATION PROCESSING FOR WIDE RANGING NEW APPLICATIONS

Of course, analog and mixed signal circuit designers are familiar with the issues of low power design and the trade-offs in noise and performance that consequently follow. Bio-compatible and self-powered systems have long required careful attention to power budgets to maintain long system lifetimes. With the surge of interest in IoT the drive to operate full systems on very low power harvesting budgets has only increased. With my background in mixed signal design, I find the issues of power, noise and performance trade-offs

to be of particular interest. The fundamental question that I have been exploring with this research is “How low can we go?” in power, and still maintain communication through a combination of both efficiency and opportunistic protocol.

Ultra-low power wireless transceivers that operate on harvested energy or tiny batteries are a critical enabler for applications in IoT (smart cities), biomedical (i.e. wireless ECG, EKG) and environmental monitoring (i.e. hazardous gas detection). However, inexpensive radios communicating continuously at power levels below 100uW, even over short distances, have been elusive for a variety of reasons. Among these reasons is a fundamental limit imposed by the power overhead required to overcome signal and receiver noise in continuous wave radios and the power required to maintain FCC compliance. In my research, I have investigated approaches to overcoming these limits through various signaling alternatives, new radio architectures, and use of effective duty cycling. My group has demonstrated that UWB impulse radios are compatible with duty cycled architectures, and can be used to push transceiver power down below 50W. However, duty cycling and wideband communication cannot be used in larger networks without robust synchronization. In order to address this challenge, we proposed a biologically inspired solution based on the behavior of South East Asian Fireflies studied by Mirrollo and Strogatz (and others). In our system, oscillators with monotonically increasing concave down state functions replicating the behavior of these fireflies emit a ‘pulse’ at the end of each cycle which is broadcasted through the wireless media and coupled into all of the nearby radio nodes. Upon reception of a pulse, a node’s local oscillator is accelerated in phase, driving it toward synchrony with the network via this non-linear coupling. We studied this design space extensively, and demonstrated a full transceiver solution in 90nm CMOS based upon this idea. This system still represents the first demonstration of a fully symmetric transceiver capable of forming an ad-hoc peer-to-peer network. To my knowledge it is also the ONLY symmetric transceiver over 1–3 meters that operates for less than 100W total power consumption, proving that such low power levels are ultimately possible. My group has also integrated a piece of this radio into a lightweight, ultra-low power dopamine sensing platform to be used in in-vivo neurotransmitter experiments in rats. We are currently working to adapt this network concept for peer-to-peer operation in the LTE-Direct system. Such a system is expected to be compatible with existing narrowband cellular systems and support the emerging need for low bandwidth ‘awareness’ of neighboring nodes for IoT. My group has designed and taped out a chip to enable scalable synchronization for duty cycling of narrow-band radios according to this vision.

## RECONFIGURABLE SOFTWARE DEFINED FDD

Wireless connectivity has dramatically enhanced the flexibility of many peoples' lives, allowing them to communicate and access information at any time from virtually anywhere. At the same time, flexibility in embedded systems, sensors, and user interfaces has allowed qualitatively new, useful capabilities to become available to the broader population through the download of a software update or app. Ironically, however, the hardware that supports wireless communication has remained stubbornly inflexible, at a significant economic and social cost that is likely to only increase. This research aims to break down the final technological barriers to low cost, flexible wireless hardware, bringing the wireless (RF) front-end in line with the rest of the hardware in modern, ultra-flexible electronic systems.

One significant challenge in RF circuits and software defined radio has been the difficulty of realizing a reconfigurable transceiver that is able to perform frequency division duplex. Through a collaboration with researchers at Cornell University, I am developing a fully integrated circuit solution that solves this problem through the construction of a real time analog signal processing engine that can

be reconfigured to filter out the large transmit signal at the receiver without corrupting the receive signal at the antenna. Building upon the work on real time signal processing, my research group developed the architecture that allows TX and RX on a single antenna at the same time via isolating the TX and RX signals, and suppressing the noise in the RX band. This circuit leverages the transversal filter architecture to allow all of these characteristics to be reconfigured over octaves of frequency. Such a transceiver has the potential to dramatically drive down the cost of handsets and other wireless interfaces, but can also be a step towards pervasive, transparent communication for billions of devices.

## CONTINUING WORK

In collaboration with the Centre for Bio-Inspired Technology, we are exploring applications of low power wireless in several new and exciting directions. Notably, we have investigated developing low power wireless interfaces for arrays of neural probes. In addition to considering duty cycled approaches, we are exploring near field methods to power and communicate with small form factor implanted smart probes.



## PROFESSOR JORGE BONDIA Universitat Politècnica de València

The artificial pancreas is a device which aims at the automatic control of plasma glucose in patients with type 1 diabetes, who lack insulin due to the autoimmune destruction of beta cells in the pancreas. It is one of those

passionate examples where multiple disciplines such as control engineering, electronics, software engineering and medicine join together working hand in hand to produce a system long-sought by patients and their families, which can be a game changer in diabetes management. Since 2006 when the Juvenile Diabetes Research Foundation in US launched the Artificial Pancreas Consortium, progress has been extraordinary. After a successful initial phase of controlled in-clinic studies, the first feasibility outpatient study was conducted in 2012 and 2016 was the year of the first pilot studies. Nowadays, a first commercial system is available in US since June 2017, although carbohydrate counting and patient intervention is still needed at mealtime. Reducing patient burden is the next step at which second generation systems must target.

Some twenty systems are, at the moment, at different stages of development, with particular features and algorithms. Among them the bioinspired Imperial College Artificial Pancreas engineered at the Centre for Bio-Inspired Technology (CBIT) and the SAFE system, from the consortium that I lead in Spain with two engineering and three clinical sites. When I visited CBIT for the first time in 2014 in a 3-month research stay, I received a question from a post-doc at CBIT, working in a different team, that shocked me: It looks like you might be competitors, what is your motivation to work with the artificial pancreas team? My answer is that I don't conceive science without collaboration. In science, the rule 1+1>2 holds (apologies to the mathematicians) and this is something that Dr. Georgiou, Dr. Herrero,

Dr. Oliver and many other excellent researchers at the Imperial College Artificial Pancreas team know well. I have always been welcomed with open arms fostering a very fruitful exchange of ideas translating in common publications, joint project proposals, active participation in projects on both sides and hosting and supervision of students. Since then, two more visits in 2015 and 2017 would follow. This open and friendly research environment has also seduced my PhD student Vanessa and my clinical collaborator Dr. Giménez who spent several months in 2017 with the team boosting their productivity.

As a control engineer, working at CBIT has taught me different approaches to the artificial pancreas, due to the strong focus of the team on building their own hardware and its bio-inspiration. Together, new bio-inspired approaches have been proposed for the first time in the field in dual hormone control, translating paracrine communication between beta and alpha cells into coordinated insulin and glucagon delivery, being currently a very active joint research. As well, I had the chance to contribute in scientific discussions and publications in ongoing projects in the field of artificial intelligence in diabetes management, such as ABC4D and PEPPER. Artificial intelligence is currently a hot topic in many domains and, of course, in diabetes management, where therapy adaptation to the many complex situations that a patient may suffer is a need. CBIT is, without doubt, one of the leading teams in this field, with application of case-based reasoning techniques both in current insulin pump therapies as well as in the artificial pancreas. Inside the context of PEPPER, they gave birth, together with other two partners in the project consortium, to the Workshop on Artificial Intelligence in Diabetes (AID), with already two editions, and which, for sure, will pave the way for an established scientific community in this field.

CBIT is no longer a collaborator, but a friend. During these years, we have built a strong relationship from the many scientific and personal synergies in both teams, which I hope is contagious among our team members. Something to really recommend for others to experience.

# Chip gallery

The Centre's researchers have produced four new chips this year making a total production so far of 62 unique chip designs in a variety of CMOS technologies. The Centre's focus is primarily the application of modern semiconductor technology to develop new bio-inspired, biomedical, and medical devices. This has in part been made possible through the EU-subsidised multi-project wafer (MPW) brokerage service provided by Europractice, which provides our design tools via STFC (UK) and technology access via IMEC (Belgium) and Fraunhofer (Germany).

See also:

## **GENERAL CHIP GALLERY**

[www.imperial.ac.uk/bio-inspiredtechnology/resources/chip-gallery](http://www.imperial.ac.uk/bio-inspiredtechnology/resources/chip-gallery)

## **NEURAL RELATED CHIP GALLERY**

[www.imperial.ac.uk/neural-interfaces/resources/silicon-chip-gallery](http://www.imperial.ac.uk/neural-interfaces/resources/silicon-chip-gallery)

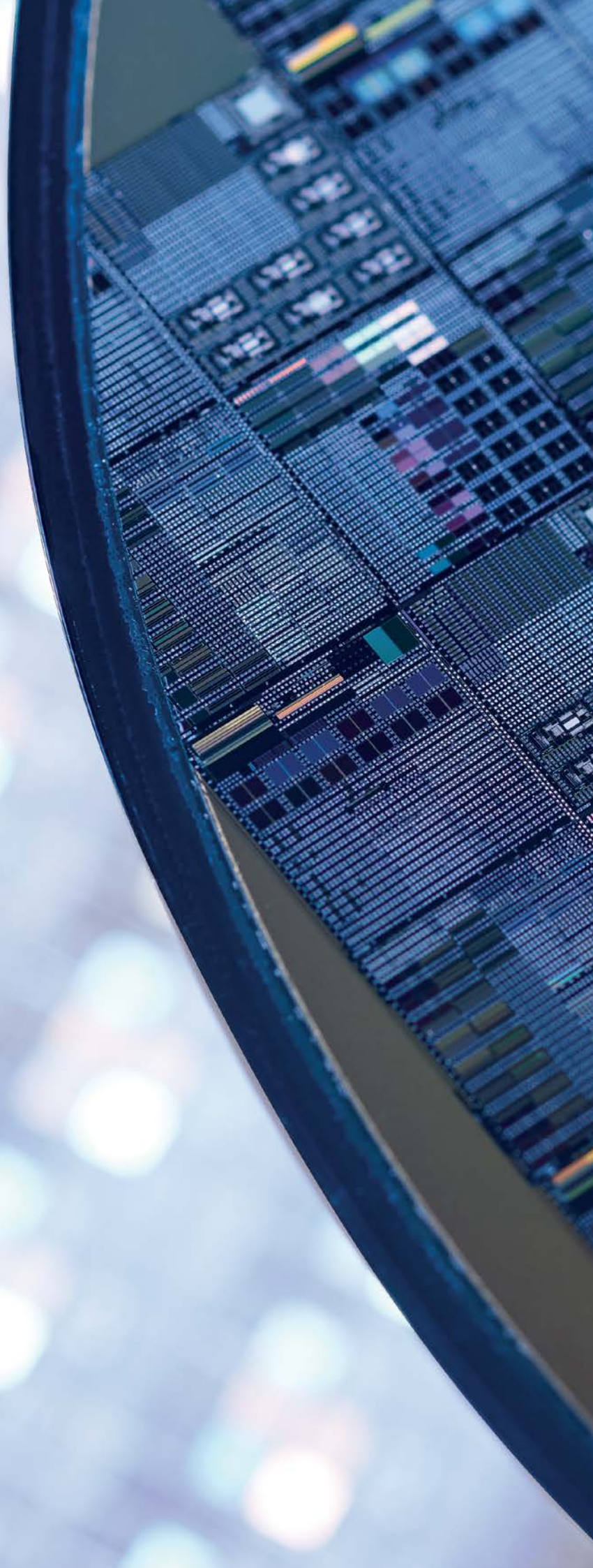

## CBIT16I01 (Pikachu)

**Technology:** TSMC 65nm CMOS LP MS RF (1P9M\_6X1Z1U\_RDL)  
**Silicon area:** 2mm × 2mm  
**Purpose:** 812-channel time domain ISFET sensing array and 4-channel time-domain neural recording system for high fidelity acquisition, filtering, processing.  
**Designers:** Nicolas Moser, Lieuwe Leene, Timothy Constandinou, Pantelis Georgiou  
**Tape-out:** September 2016

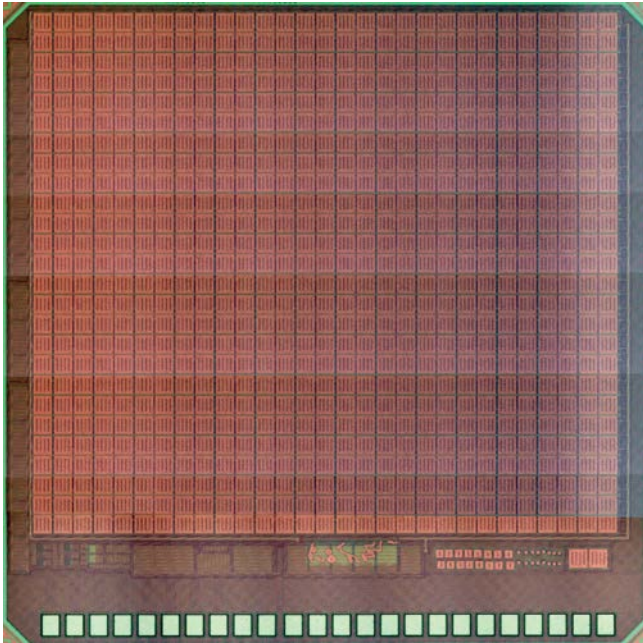

## CBIT17F01 (Voyager)

**Technology:** AMS 0.35μm 2P4M CMOS (C35B4C3)  
**Silicon area:** 4mm × 4mm  
**Purpose:** ENGINI mm-scale, freely-floating neural acquisition fully autonomous System-on-Chip.  
**Designers:** Lieuwe Leene, Michal Maslik, Peilong Feng, Federico Mazza, Katarzyna Szostak, Timothy Constandinou  
**Tape-out:** June 2017

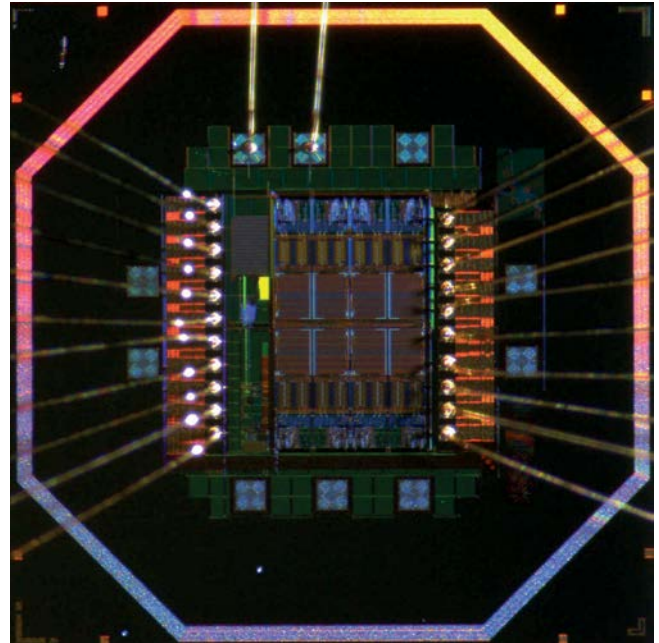

## CBIT17F02 (CandoTest)

**Technology:** AMS 0.35μm 2P4M CMOS (C35B4C3)  
**Silicon area:** 2mm × 3.5mm  
**Description:** Test structures for reliability testing of implantable packaging and continuous-time ADC design.  
**Designers:** Federico Mazza, Yan Liu, Timothy Constandinou  
**Tape-out:** June 2017

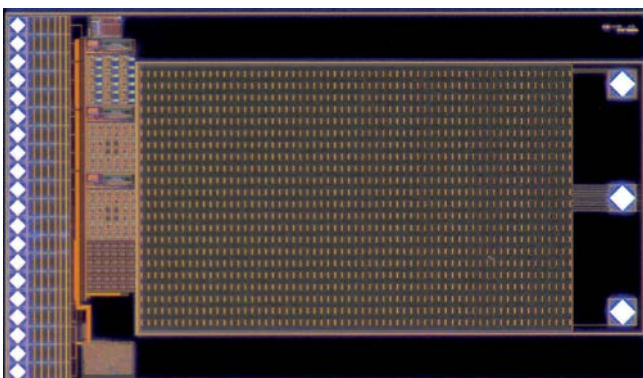

## CBIT17F03 (TITANICKS2)

**Technology:** AMS 0.35μm 2P4M CMOS (C35B4C3)  
**Silicon area:** 3.9mm × 3.9mm  
**Description:** Chemical sensing array for ion imaging and DNA detection.  
**Designers:** Nicolas Moser, Nicholas Miscourides, Pantelis Georgiou  
**Tape-out:** June 2017

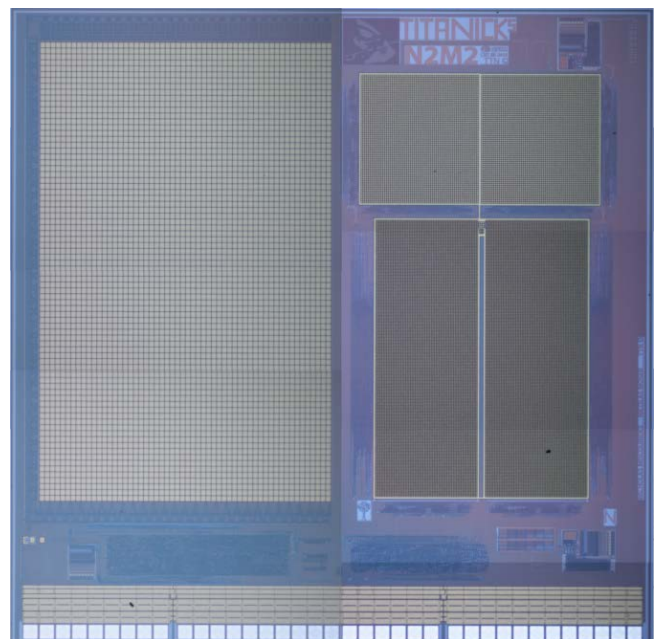



# XCBIT Research gallery

This year saw the launch of our XCBIT Research Gallery (unveiled in January 2017). This is a dedicated space we have developed for showcasing outcomes of our research, combined with a collaborative work environment for our chip design reviews.

The gallery features sections on Personalised Healthcare, Implantable Devices, Bio-Inspired Systems and Wearable Technology. In addition to sample devices that are on display, we have developed a number of live demonstrators including a biologically-inspired pancreas for type-I diabetes, an advanced bolus calculator for diabetes, a real-time neural spike sorting platform, with several others soon to be added.

We intend on utilising this space for dissemination purposes during visits from our funders, visitors and events we organise for outreach and public engagement. This year saw several such events including a “Behind the Scenes” evening event on Next Generation Neural Interfaces we hosted for Friends of Imperial, a site visit for the EPSRC ICT team, and laboratory tour for the EEE departmental Strategic Advisory Group.



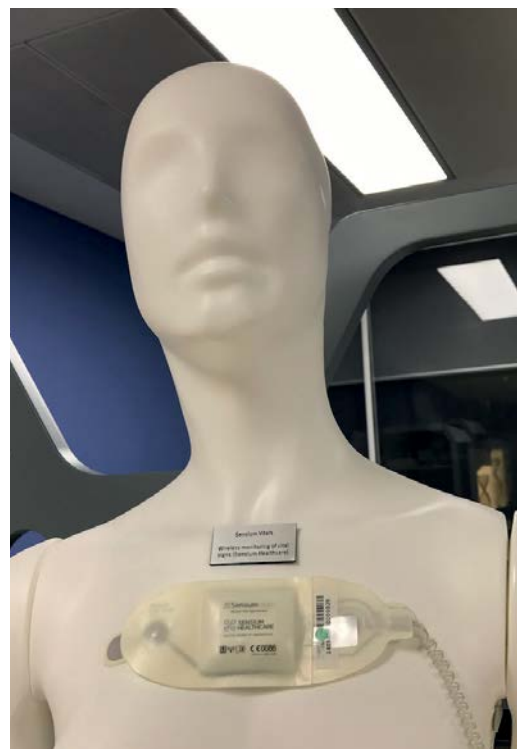
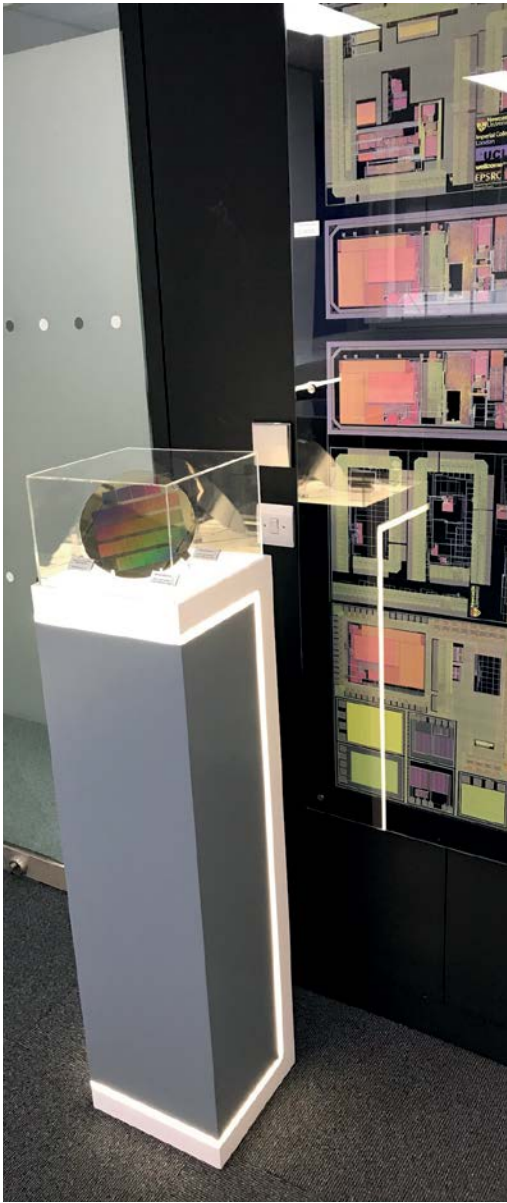



The laboratory areas have been designed to meet the needs of the four main application areas within the Centre's research strategy. Researchers have been able to undertake a large number of high-quality research projects in the Centre by leveraging on the multidisciplinary expertise of their colleagues and collaborators and the employment of the facilities.

# Research facilities

---

The main thrust of the research strategy is not to further advance the performance of existing electronic systems but to enable entirely new applications by utilizing well-established technologies in new, innovative ways. All members of the Centre have access to the full range of facilities and equipment and some researchers have developed a high level of expertise in specific areas to ensure that these are exploited to the full.

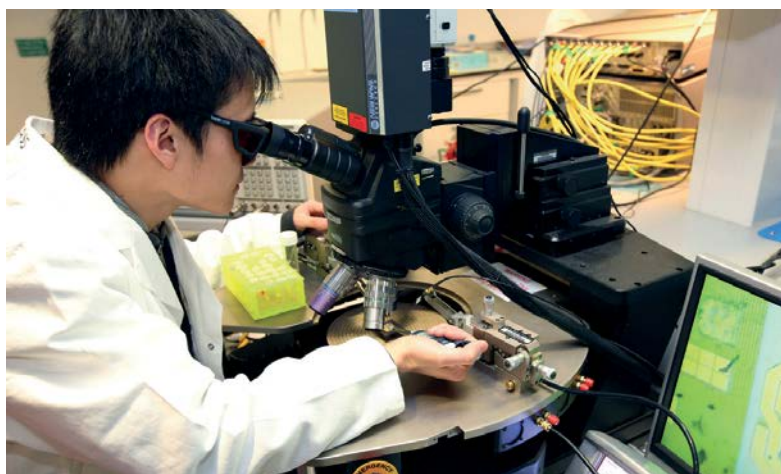

## XCBIT CAD LABORATORY

The Centre for Bio-Inspired Technology hosts a CAD Laboratory equipped with high-end workstations and industry-strength EDA tools for the design, simulation & verification of integrated circuits & microsystems.

CAD is an indispensable process in any modern engineering design. This laboratory is equipped with high performance workstations and servers to support high-end tools for microelectronic design, microsystems (including MEMS, microfluidics), RF/microwave devices, mechanical design, etc. For example, researchers here develop application-specific integrated circuits (ASICs) that are then sent for fabrication at CMOS foundries. The facility has licensed all industry standard tools including Cadence, Mentor Graphics, Synopsys, Ansys, Solidworks, and several others, and a range of modern process technologies down to the 45nm node. All servers can be remotely connected from anywhere around the world via the internet enabling designers to work remotely and multiple chip designs can be carried out in parallel.



### ELECTROMAGNETICS TEST LABORATORY

Within this facility is a large, shielded, certified anechoic chamber, valid up to 34GHz, a 67GHz Agilent PNA with Cascade manual probe station and E-CAL automatic calibration for discrete SMA socketed use (up to 26.5GHz), an 8GHz 40Gs/s Agilent oscilloscope and a Picosecond pulse generator, as well as a host of other miscellaneous instruments. It is unique for the Centre to have access to such a chamber and it provides an ideal test facility for any project involving on-body or in-body antennas and indeed the communication between both. This, in conjunction with equipment such as the Agilent PNA and Dielectric Probe facilitates the use of anatomically and electromagnetically correct bio-phantoms to replicate the losses incurred when sensors and antennas are implanted in the body, leading to quicker prototype development and proof of concept.

### ANECHOIC (RF AND ACOUSTIC) TEST CHAMBERS

State-of-the-art soundproof and electromagnetic radiation proof chambers for ultra-low noise sensing. The acoustic facility includes a large (5m x 5m x 2m) anechoic shielded chamber providing an extremely low-noise environment suitable for all low frequency acoustic, optical and mechanical device/sensor characterisation. The RF facility includes a large (4m x 3m x 2m) anechoic shielded chamber suitable for a wide range of low noise measurements with significantly attenuated electromagnetic levels. This has been calibrated for uninterrupted use between 10MHz and 34GHz.

### CLEANROOM SUITE

The Centre has a suite of two ISO class 6 cleanrooms (equivalent to US standards class 100). These have been designed to support CE Marking/FDA approvals, to class 100/1000 to develop biosensor devices, electrode and microfluidic fabrication, packaging/post-processing of CMOS chips and support research in any other areas requiring particle-free environment.

The largest room, the 'yellow' room, houses most of the fabrication tools/processes and all relevant inspection and measurement facilities. This includes photolithography tools – mask aligner with Nano Imprint Lithography (NIL) attachment, direct laser

writing system, 3D laser nanolithography, two PVD systems for thin film deposition of metals, oxides and organics, surface characterisation tools, oxygen plasma chamber as well as wet and dry benches. Smaller 'white' room houses various equipment allowing for wet silicon oxidation, wire bonding, Parylene deposition and electrochemical processes.

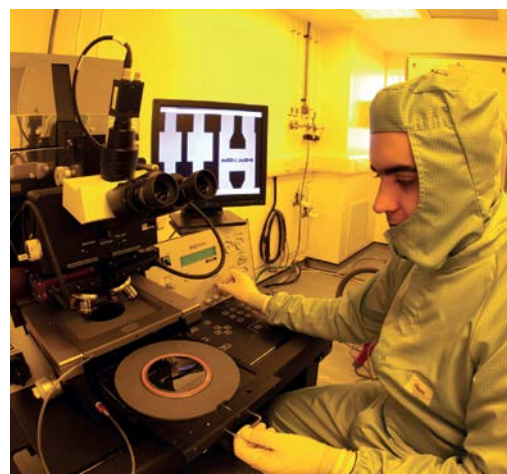

### MICROELECTRONICS LABORATORY

This laboratory is comprehensively equipped for the development, testing and measurement of biomedical circuits and systems. Such devices often require low noise instrumentation operating at relatively low frequency and have ultra low power requirements. This facility includes instruments for semiconductor characterisation, equipment for time, frequency and impedance characterisation (e.g. oscilloscopes, spectrum analysers, CV), instruments for low noise transimpedance and voltage amplification, signal generation, a semi-automatic probe station with laser for trimming and failure analysis, a temperature chamber, PCB rapid prototyping facility (LPKF-based), and all standard electronic test & measurement equipment.

### BIOTECHNOLOGY LABORATORY

The Biotechnology Lab is the first of its kind in the Department of Electrical and Electronic Engineering and it contains all necessary equipment for molecular biology and cell culture work, with focus on infectious diseases and cancer. The facility includes separate pre- and post-PCR areas to minimise DNA contamination, with instruments for extraction, analysis, manipulation and storage of genetic material. The laboratory is equipped with a Class II biological safety cabinet for pathogen containment, contamination control and sterility, a PCR-workstation with laminar flow and UV to prevent unwanted contamination and a laminar fume hood for working with hazardous chemicals is also installed. A CO<sub>2</sub> incubator and an inverted fluorescence microscope for cell culture work are also in place. In addition to these; authorised users have access to two conventional thermal cyclers, two quantitative real-time PCR instruments, -80C and -20C freezers, a horizontal gel electrophoresis system, and all standard lab equipment such as micropipettes, microfuges, pH meters, vortex mixers, balances, dry bath incubators and bench-top centrifuges.



# Who we are

---

**Academic staff profiles — 36**

**Administrative staff profiles — 41**

**Staff research reports — 42**

**Research student & assistant reports — 64**

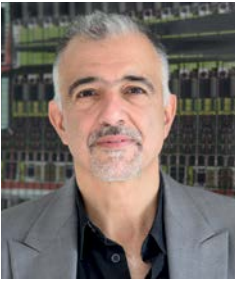

## Professor Chris Toumazou

Regius Professor of Engineering  
 Director, Centre for Bio-Inspired Technology  
 Chief Scientist, Institute of Biomedical Engineering  
 Winston Wong Chair in Biomedical Circuits, Department of Electrical and Electronic Engineering

Toumazou's life work has been dedicated to saving and improving lives through the invention of revolutionary, innovative and disruptive technology and the creation of a leading edge medical research institute and three commercial ventures to commercialize his research.

Toumazou is a Professor of Analog Circuit Design, Chief Scientist and Founder of Imperial's first Institute of Biomedical Engineering, Research Director of the Centre for Bio-inspired Technology, and Winston Wong Chair in Biomedical Circuits at the Electrical and Electronic Engineering Department at Imperial College London. He was made a Professor at Imperial College London at 33, one of the youngest ever to achieve this distinction. In 2013 he was appointed the first Regius Professor of Engineering, an award made to Imperial College London to celebrate the Diamond Jubilee of Her Majesty The Queen.

Toumazou's career began with the invention and development of entirely novel concept of current-mode analogue circuitry for ultra-lowpower electronic devices. Since then, he has been involved in inventing, developing and demonstrating new technologies to meet a range of healthcare challenges – mainly applying silicon chip technology to biomedical and life-science applications, most recently to DNA analysis. In particular, Toumazou invented and licensed Portable and Rapid Semiconductor Genome Sequencing which has now become a multi-million dollar industry. One of his motivators was the diagnosis of his 13-year old son with end-stage kidney failure through a rare genetic mutation.

DNA Electronics, a company founded by Toumazou in 2003, was awarded \$51.9 million contract to DNAe to develop semiconductor DNA sequencing platform for rapid diagnosis of antimicrobial resistant infections and influenza by the Biomedical Advanced Research and Development Authority (BARDA) a division in the U.S. Department of Health and Human Services (HHS).

In 2015 he co-founded dnaNUDGE pioneering a new breed of consumer genetics testing. The company harnesses groundbreaking DNA testing and application technology to 'nudge' people towards healthier shopping choices based on their unique genetic profile. The vision for dnaNUDGE is improved public health, driven by consumers empowered by the information and assistive app technology to help them make healthiest choices for their genetic characteristic.

In 2003 he raised a total of £26m to create the Institute of Biomedical Engineering at Imperial College London, a multidisciplinary research institute and hub focusing on personalised medicine and bionanotechnology. He became its first Director (2004) and Chief Scientist (2011). His own specialism is in the field of personalised healthcare, providing wearable or implantable devices for early diagnosis and detection of disease.

He was elected Fellow of the Royal Society (2008), Fellow of the Royal Academy of Engineering (2008) and Fellow of the Academy of Medical Sciences (2013), making him one of a handful in the UK who are fellows of all three premier societies. Toumazou has received numerous awards and prizes for his innovative research including the 2009 World Technology Award for Health and Medicine, the Silver Medal of the Royal Academy of Engineering in 2007 and in 2010 Honorary DEng from Oxford Brookes University. In 2009 he gave the Keynote Lecture to mark the IEEE 125th Anniversary celebrations in Europe at the Royal Institution. He has given numerous public lectures and keynote addresses at a national and international level. In 2011 he was invited to speak at the TEDMED conference in San Diego; his lecture entitled 'When Will Wireless Medicine Change Healthcare'. Other notable lectures include the G8 Summit (2013) and Royal Society public talk (2011).

In June 2014 Professor Toumazou's technology was also recognised by the European Patent Office when he was awarded the prestigious 2014 European Inventor of the Year Award for Research making him the first British winner since 2008. Toumazou has also been awarded by Cardiff University with Honorary Fellowship in 2014 and later that year – in November 2014 – the Faraday Medal, the highest honour of the UK's Institution of Engineering and Technology (IET) for the invention of semiconductor sequencing and pioneering work that has led to disposable semiconductor healthcare. To date Chris has published over 750 research papers and holds more than 50 patents in the field of semiconductors and healthcare, for which he has received many awards and honours.



## Timothy Constandinou, PhD

Reader in Neural Microsystems – Department of Electrical & Electronic Engineering  
Deputy Director – Centre for Bio-Inspired Technology

Dr Timothy Constandinou is a Reader in Neural Microsystems at Imperial College London and also Deputy Director of the Centre for Bio-inspired Technology. He received both his BEng and PhD degrees in Electrical and Electronic Engineering from Imperial College London, in 2001 and 2005 respectively. He then joined the Institute of Biomedical Engineering as Research Officer until 2009, when he was appointed Deputy Director of the newly formed Centre for Bio-Inspired Technology. In 2010, continuing as Deputy Director, he joined the Department of Electrical & Electronic Engineering, where he currently holds an academic faculty position within the Circuits & Systems research group.

He leads the Next Generation Neural Interfaces (NGNI) research group ([www.imperial.ac.uk/neural-interfaces](http://www.imperial.ac.uk/neural-interfaces)) at Imperial; a multidisciplinary team of approx. 15 researchers. The group utilises integrated circuit and microsystem technologies to create advanced neural interfaces that enable new scientific and prosthetic applications. The ultimate goal is to develop devices that interface with neural pathways for restoring lost function in sensory, cognitive and motor impaired patients.

During his career he has contributed to several projects from concept through to working demonstrator. This includes developing a fully implantable cochlear prosthesis for the profoundly deaf (2001–2), biologically inspired vision chips (2003–5) and an implantable vestibular prosthesis for balance restoration (2006–9). His latest research (2010 onwards) has focused on two key themes:

- **Resource efficiency:** developing low power/area/communication bandwidth real-time systems for neural interfacing that combine recording, processing, stimulation and communication.
- **Microsystems integration:** taking a holistic approach in the design process driven by the physical embodiment (packaging/encapsulation, deployment, power, etc), in particular for implantable and wearable devices.

Current projects include:

- **EPSRC Early Career Fellowship (ENGIN) – Empowering Next Generation Implantable Neural Interfaces:** creating truly wireless, autonomous, chip-scale implants for distributed sensing.
- **CANDO – Controlling Abnormal Network Dynamics with Optogenetics (supported by the Wellcome Trust and EPSRC):** a next generation brain pacemaker for the treatment of drug-insensitive epilepsy (in collaboration with Newcastle University, Newcastle Upon Tyne Hospitals and UCL).
- **Enabling Technologies for Sensory Feedback in Next Generation Assistive Devices (supported by the EPSRC):** a platform for providing sensory feedback via a PNS interface in upper-limb prosthetics (in collaboration with the Universities of Newcastle, Southampton, Leeds, Keele, and Essex).
- **Investigating new modalities for observing neural activity (supported by EPSRC DTAs and platform), including:** “functional neuroimaging using ultra-wideband impulse radar” and “optical neural recording (without optogenetics) for large-scale activity monitoring”.

Within the IEEE and IET he serves on several committees/panels, etc, regularly contributing to conference organization, technical activities and governance. He is currently associate editor of IEEE Trans. Biomedical Circuits & Systems (TBioCAS), is Chair of the IEEE Sensory Systems Technical Committee, a member of the IEEE BRAIN Initiative Steering Committee, member of IEEE BioCAS Technical Committee, and serves on the IEEE Circuits & Systems Society Board of Governors (BoG) for the term 2017-19. He was Technical Program Chair of IEEE BioCAS conference (Paphos, 2010 and San Diego, 2011), General Co-Chair of 1st IEEE BrainCAS workshop (Hangzhou, 2016), Special Session Chair of IEEE ISCAS (Baltimore, 2017), and Demonstrations Chair of IEEE BioCAS (Turin, 2017). He will be Technical Program Co-Chair of the 2018 IEEE BioCAS Conference and General Chair of the 2nd IEEE BrainCAS/NeuroCAS workshop both in Cleveland, Ohio.



## Pantelis Georgiou, PhD

Reader in Biomedical Electronics, Department of Electrical and Electronic Engineering  
Director, Bio-Inspired Metabolic Technology Laboratory, Centre for Bio-Inspired Technology

Pantelis Georgiou is a Reader in Biomedical Electronics at Imperial College London and head of the Bio-Inspired Metabolic Technology Laboratory in the Centre for Bio-Inspired Technology. His research includes ultra-low power micro-electronics, bio-inspired circuits and systems, lab-on-chip technology and application of micro-electronic technology to create novel medical devices.

Dr. Georgiou graduated with a 1st Class Honours MEng Degree in Electrical and Electronic Engineering in 2004 and Ph.D. degree in 2008 both from Imperial College London. He then moved to the Institute of Biomedical Engineering where he was appointed as a Research Fellow and head of the Bio-inspired Metabolic Technology lab in CBIT. In 2011, continuing his role in the Centre, he joined the Department of Electrical & Electronic Engineering, where he currently holds an academic faculty position within the Circuits & Systems research group. He has made significant contributions to integrated chemical-sensing systems in CMOS, conducting pioneering work on the development of Ion-Sensitive Field-Effect Transistors, which has enabled applications, such as point-of-care diagnostics and DNA detection systems and has also developed the first bio-inspired artificial pancreas for treatment of Type I diabetes using the silicon-beta cell.

In 2004, he was awarded the Imperial College Governors' Prize for Electrical and Electronic Engineering and in 2013 he received the IET Mike Sergeant award for outstanding achievement in engineering and his work on the Bio-inspired Artificial pancreas. In 2017, he became an IEEE Distinguished Lecturer in Circuits and Systems and received the IEEE Sensors Council Technical Achievement award for significant contributions in bioelectronics through the development of the Bio-inspired Artificial Pancreas and innovations in ISFETs for rapid diagnostics.

His current projects include:

- **The Bio-inspired artificial pancreas** – Type 1 diabetes results in the body's inability to secrete insulin, resulting in high blood glucose, with major complications and risks if left unmanaged. This project has developed a closed-loop system for tight glycemic control inspired by the biology of the pancreas. The bio-inspired artificial pancreas controls blood sugar continually through intensive insulin infusion improving quality of life and reducing adverse effects of diabetes.
- **Decision support systems for management of diabetes** – This research aims to create novel decision support systems for Type 1 and Type 2 Diabetes

based on artificial intelligence algorithms to help manage blood glucose control in diabetes through guided supervision. Such systems are capable of factoring in multiple parameters such as blood glucose, exercise, meals and stress in a single platform, all of which affect patient outcome, allowing more targeted monitoring and control on a daily basis.

- **Next generation ISFET arrays for ion-imaging and point-of-care diagnostics** – Semiconductor based chemical sensing using Lab-on-CMOS platforms is becoming an attractive alternative to conventional optical sensing methods due to their capability to integrate millions of sensors on a single substrate to create sensing arrays, offering the ability to create small form factor point-of-care diagnostics and low-cost devices. My lab is developing next generation chemical sensing arrays using ISFETs. Our applications include rapid diagnostics for infectious disease and ion-imaging for cells-on-chip and multiple metabolite monitoring.
- **Infection Technology targeted towards developing countries** – This project aims to create novel diagnostics and analytics capable of combating the growing threat of infectious disease in developing countries. This involves the development of intelligent Lab-on-chip diagnostic systems which comply with ASSURED Criteria and contain connected capability for data-analytics and decision support. A consortium of collaborating countries and world-renowned centers has been formed including Brazil, Thailand, Vietnam, South Africa, Singapore and Taiwan targeting infections such as dengue, zika, chikungunya, malaria and tuberculosis.
- **Real time muscle fatigue detection for smart rehabilitation** – This project will create a real-time method for tracking muscle fatigue for applications in rehabilitation and sport physiotherapy. Through specific continuous-time techniques, we have created an energy efficient, miniaturised system in CMOS that extracts muscle fatigue recordings (or data or events) through monitoring of EMG signals.

Dr Georgiou is a senior member of the IEEE (Institution of Electrical and Electronic Engineers), member of the IET (The Institution of Engineering and Technology) and a Chartered Engineer (CEng). He serves on the BioCAS (Biomedical Circuits and Systems) and Sensory Systems technical committees of the IEEE CAS Society, is an associate editor of the IEEE Sensors and TBioCAS journals and also sits on the IET Awards and Prizes committee. He is the CAS representative on the IEEE sensors council and the 2017-18 IEEE Distinguished Lecturer in Circuits and Systems.



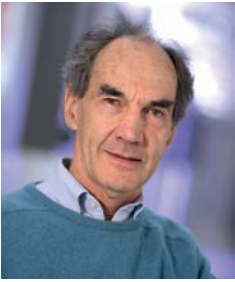

## Professor Chris McLeod

Principal Research Fellow, Centre for Bio-Inspired Technology

Chris McLeod was appointed Principal Research Fellow in Cardiovascular Instrumentation in 2009 after joining the IBE at its inception in 2005 as a Visiting Professor. Until 2008 he had been a Professor of Electronic Engineering at Oxford Brookes University where he led research in Medical Devices in collaboration with the clinical departments of Anaesthetics, Neurophysiology and Paediatrics, holding an Honorary Research Fellowship in the Department of Anaesthetics. The research activities were mainly funded by the Wellcome Trust and EPSRC. Prior to joining Oxford Brookes he worked with clinical research groups in Paediatrics and the Nuffield Institute for Medical Research in Oxford. He received an MA degree in Engineering from Cambridge, an MSc in Bioengineering from Strathclyde and a D.Phil in Bioengineering from Oxford.

His research has, in the past, been based on minimally-invasive sensing of physiological data for patients in intensive care, both adult and neonatal, to improve the quality of signals, to increase the value of recorded signals and to decrease the obtrusiveness of recording apparatus. He currently leads the research group developing permanently implantable sensors for monitoring the cardiovascular system in ambulatory patients at home with long-term conditions and piloting implantable sensors for other medical

applications. The monitoring system delivers objective data to a clinician or server through a wide-area network. The sensors are based on acoustic resonators which can be powered and interrogated wirelessly from the body surface.

### MOTIVATION FOR CURRENT RESEARCH

There is a hypothesis that objective measurements of Pulmonary Arterial Pressure can be used to determine the optimal pharmaceutical therapy for patients with progressive heart failure. If optimal, patients will have the minimum morbidity (i.e. best achievable quality of life) and disease progression will be retarded. Early indications from permanently implanted sensors measured once daily in an American trial (CHAMPION) show a significantly reduced re-hospitalisation rate in patients. We believe that an ambulatory monitoring regime will further improve the data available to optimise therapy, with the added potential of being a clinical alarm system.

His current research and development programme is funded by the Wellcome Trust and Department of Health for which he is extremely grateful. The IBE at Imperial has been an excellent base for this activity, so thanks also to Chris Toumazou for making him welcome here.

*Simultaneous recordings of porcine left ventricular pressure from a catheter-tip transducer (green) and SAW sensor (blue)*

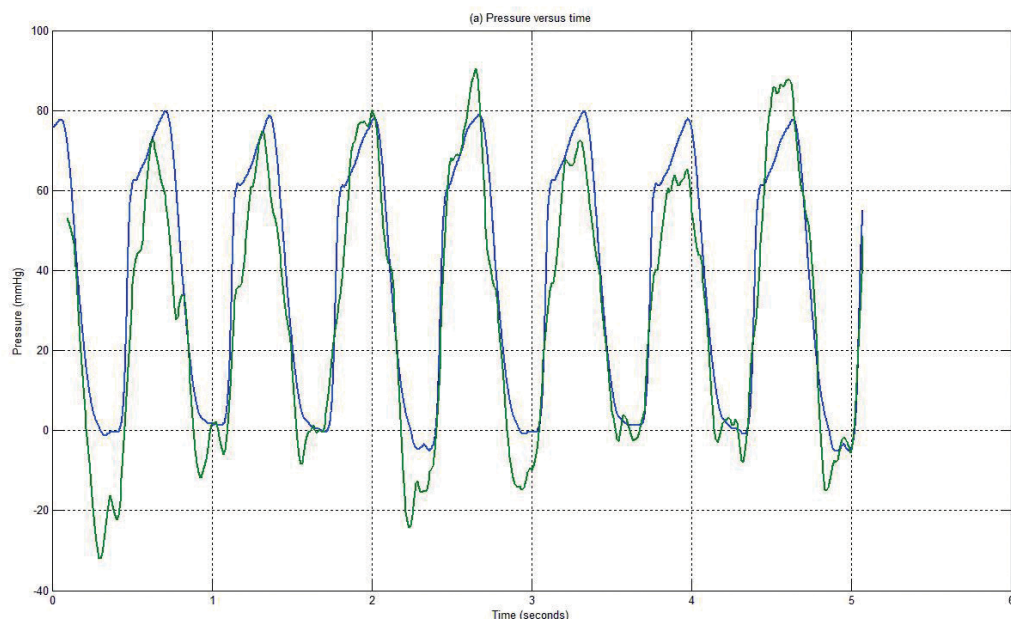



## Konstantin Nikolic, PhD

Senior Research Fellow

Konstantin received a DiplEng and Masters from the Department of Electrical Engineering, Belgrade University, Serbia and a PhD in Condensed Matter Physics from Imperial College London. He was a Lecturer and Associate Professor at the Faculty of Electrical Engineering, Belgrade University (teaching Physics, Quantum Mechanics and Semiconductor Devices) in the period 1994-1999. Then he moved to UCL (Department of Physics and Astronomy, Image Processing Group) until he joined the Institute of Biomedical Engineering, Imperial College London in 2005. In 2006 he became Corrigan Research Fellow and in 2012 Senior Research Fellow.

Dr Nikolic leads the **Bio-modeling group** at the CBIT, which develops methods and computational tools for understanding, modelling and simulating various biological and physiological processes and their applications in bio-inspired electronic systems. Bio-modelling tries to capture the complexity of biophysical, biochemical and bioinformatic processes at different scales, from individual molecules to complete organisms, in relatively simple models. These models and computational simulations provide useful insights, and represent a fundamental basis in understanding how to design new bio-inspired devices.

Dr Nikolic is also leading the research management of i2MOVE project, which is developing a closed loop system for neural recording and stimulation.

Current projects include:

- **Optogenetics:** Prometheus – A publically available web Portal for Computational Neuroscience along with a Graphical User Interface (BBSRC Impact Acceleration Award, PI). It provides the tools for computational optogenetics (PyRhO) together with the NEURON and Brian2 platforms available with no installation or configuration, eliminating all related potential frustrations to users, especially those with a limited computational background. The portal is currently hosted on the Digital Ocean cloud infrastructure (<http://try.projectpyrho.org>).
- **Optogenetics:** PyRhO – Multiscale Computational Platform for Optogenetics (BBSRC funding, PI). The module is written in Python with an additional

iPython/Jupyter notebook based GUI, allowing models to be fit, simulations to be run and results to be shared through simply interacting with a webpage. The model fitting algorithms are seamless integrated with simulation environments, including NEURON and Brian2.

- **Neurotechnology:** i2MOVE – Intelligent Implantable Modulator of Vagus Nerve function for treatment of obesity (ERC). The project develops a new generation of neural interfaces that combines novel electrode materials, structures and sensing modalities with low power electronic neural recording, analysis, stimulation and wireless communication.
  - **Machine Learning:** Cancer Breathalyser – Development of a machine learning algorithm for a breathalyser device for cancer detection (Wellcome-Imperial Strategic Support, Co-I). The project also includes a statistical analysis of the volatile organic compounds concentrations in the exhaled breath for searching for markers for different types of cancers.
  - **Neuromorphic systems:** Combining several neuromorphic devices, such as Dynamic Vision Sensor ('the eye'), SpiNNaker board (spiking neural networks simulation platform – 'the brain') and a servo ('the hand') into a robotic system, for completing simple cognitive tasks with sensory inputs, such as robot goalie.
  - **Platform Grant for Disruptive Semiconductor Technologies for Advanced Healthcare Devices (EPSRC, Co-I).** Provides support and 'platform' for initiating, testing and finding a longer term support for a number of new ideas in the area of cancer detection, neural recording and stimulation, and anti-microbial resistance research, as well as for keeping existing expertise and talent in the group and bringing new.
- Dr Nikolic is a member of the IEEE Biomedical Circuits and Systems (BioCAS) Technical Committee, EPSRC Peer Review College member, reviewer for the Einstein Foundation Berlin, and IEEE BioCAS conference review committee member for Medical Information Systems and Bioinformatics.

## ADMINISTRATIVE STAFF PROFILES



[www.imperial.ac.uk/people/w.hsissen](http://www.imperial.ac.uk/people/w.hsissen)

### Wiesia Hsissen

Senior Group Administrator, Circuits and Systems Research Group, Department of Electrical and Electronic Engineering

Wiesia is the senior group administrator of the Circuit and Systems (CAS) research group and additionally has the role of PA to the Head of Department. She joined the Department of Electrical and Electronic Engineering in 1990 and has kept a key role in supporting the CAS group ever since.

Her role within the Centre for Bio-Inspired Technology is to support our postgraduate research students from PhD registration and bursaries to thesis submission and examination.



[www.imperial.ac.uk/people/g.osei-ansah](http://www.imperial.ac.uk/people/g.osei-ansah)

### Gifty Osei-Ansah

PA to Professor Chris Toumazou

Gifty joined the Centre in 2010 as PA to Professor Toumazou. She provides the essential support he needs to fulfil his various roles including as Director of the Centre, Professor of Biomedical Circuits in the Department of Electrical and Electronic Engineering and CEO to Toumaz Ltd and DNA Electronics Ltd.



[www.imperial.ac.uk/people/i.wojcicka](http://www.imperial.ac.uk/people/i.wojcicka)

### Izabela Wojcicka-Grzesiak

Senior Group Administrator,  
Centre for Bio-Inspired Technology

Iza is the group administrator for the Centre for Bio-Inspired Technology. She originally joined Imperial in 2006 as an administrator within the Institute of Biomedical Engineering and was appointed group administrator of the Centre in 2009 when it was formed.

Iza now plays a key role within the Centre supporting staff, students, research and facilities. Within her role she deals with all matters relating to finance, HR, health and safety and general administration.



[www.imperial.ac.uk/people/joao.reis](http://www.imperial.ac.uk/people/joao.reis)

### Joao Reis

Project administrator (part time)

Joao is the Project Administrator for the EPSRC project, 'Engineering, Physical, Natural Sciences and Medicine; Bridging Research in Antimicrobial Resistance; Collaboration and Exchange (EMBRACE)'. His role is to support the EMBRACE Fellows and multidisciplinary collaborations around antimicrobial resistance.



## Mohammad Reza Bahmanyar, PhD

### Research focus

Wireless Medical Implants and Devices

### Funding

Wellcome Trust

### MOTIVATION

Medical devices play an important role in improving the quality of life of patients across the world. These devices are often the result of multidisciplinary research, where different technologies are used and work together. Rapid advancement of technology in different areas and ever increasing need for new medical devices (e.g. due to the aging population) means that the future of healthcare will rely on efficient convergence of multiple disciplines. Understanding and utilizing science and technology in a creative way to develop novel medical devices that can potentially help patients is the main drive in my research.

### OBJECTIVES

Measuring physical (e.g. pressure) and biochemical (e.g. glucose concentration) quantities inside the human body can assist in managing relevant medical conditions and assessing the efficiency of treatments. This requires biocompatible miniature implants of high longevity that can be interrogated wirelessly. Producing such devices is challenging and demands creative use of existing, and developing novel, technologies to achieve:

- Miniaturization without compromising the functionality.
- Increasing the longevity without compromising safety and biocompatibility.
- No cross-interference with other wireless systems.
- Devising ways of using the acquired data to maximize the benefit to the patient and minimize the cost to the healthcare system.

### RECENT ACHIEVEMENTS

- Implantable SAW Transponder for Acute and Chronic Blood Pressure Monitoring. (As Col)
  - Co-founding a Spin-out Company (Cardian Ltd) that attracted £1.5M seed funding from Touchstone Innovations.
  - Four international patent applications (PCT) has been filed on the technology that is licensed to Cardian.
- Development of a Novel Angioplasty Catheter for Treatment of Calcified Arteries (as PI)
  - Funding secured (~£1.18M) from MRC.

An international patent application (PCT) has been filed on the technology.

- Micro Mems glaucoma pressure sensor (as PI)
  - £25k is secured from Imperial Innovations to continue the project.

### BIOGRAPHY

Dr Bahmanyar received his PhD from Brunel University in 2006. He has been doing research at the interface of engineering/physics with medicine for seventeen years developing medical devices including working with manufactures and regulators. He joined the Institute of Biomedical Engineering in 2009. Currently, he directs research on cardiovascular devices and ocular implants; also in collaboration with Cardian and as a member of a team, funded by the Wellcome Trust and DOH, he works on the optimization of an implant system for pulmonary artery pressure monitoring, intended for a phase I trial and FDA submission. His research has attracted significant commercial interest.

### PUBLICATIONS

- S Lee, H Aguib, J Chapron, M Bahmanyar, A Borghi, O Murphy, C McLeod, A ElGuindy, M Yacoub, "Spatial Orientation and Morphology of the Pulmonary Artery: Relevance to Optimising Design and Positioning of a Continuous Pressure Monitoring Device," in *Journal of Cardiovascular Translational Research*, vol. 9 (3), pp. 239-48, June 2016, doi: 10.1007/s12265-016-9690-4.
- O Murphy, A Borghi, M Bahmanyar, C McLeod, M Navaratnarajah, M Yacoub, C Toumazou, "RF communication with implantable wireless device: effects of beating heart on performance of miniature antenna," *Healthcare Technology Letters*, Volume 1, Issue 2, pp. 51-55, June 2014, DOI: 10.1049/hlt.2014.0066, Online ISSN 2053-3713.
- M Zolgharni, N M Dhutia, G D Cole, M R Bahmanyar, S Jones, S Sohaib, S Tai, K Willson, J Finegold, D Francis, "Automated Aortic Doppler Flow Tracing for Reproducible Research and Clinical Measurements," in *IEEE Transactions on Medical Imaging*, vol. 33, no. 5, pp. 1071-1082, May 2014. doi: 10.1109/TMI.2014.2303782
- O Murphy, M Bahmanyar, A Borghi, C McLeod, M Navaratnarajah, M Yacoub, C Toumazou, "Continuous in vivo blood pressure measurements using a fully implantable wireless SAW sensor," in *Biomedical Microdevices*, April 2013; DOI 10.1007/s10544-013-9759-7.

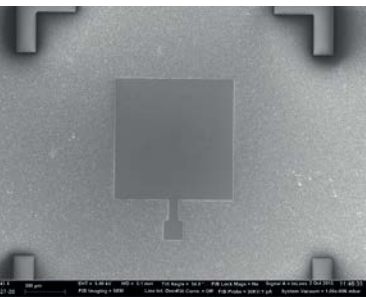

A film bulk acoustic wave resonator for IOP measurement



SAW pressure sensing implant for pulmonary artery



## Nir Grossman, PhD

### Research focus

Noninvasive Human Neuromodulation

### Funding

Wellcome Trust

Neuromodulation is widely used to study and treat the brain, presenting an attractive alternative for pharmacology treatment. Transcranial alternate current stimulation (TACS) is a new neural modulation method that uses weak, exogenous and periodic electric fields for synchronizing neural activity. TACS has been showing already very interesting neurobiological and behavioral effects despite a lack of exact understanding of the mechanism by which the mesoscopic neural oscillatory dynamics is modulated. The concept of remote modulation of the brain's oscillations - a hallmark of physiological and pathological functions, is very new and bears exciting engineering and clinical challenges and opportunities.

### OBJECTIVE

- To develop mechanistic principles to achieve targeted and individualized noninvasive modulation of human brain oscillations.

### RECENT ACHIEVEMENTS

During the last 12 months, Nir and collaborators at MIT have completed first human testing of a novel brain stimulation technology, called temporal interference stimulation.

In addition, in collaboration with UCLH, Nir have been employing a new method to explore how phase-locked brain stimulation can help suppress tremor activity in essential tremor patients.

### BIOGRAPHY

Nir is a Wellcome Trust MIT Fellow with Prof. Chris Toumazou, working with Prof. Ed Boyden (MIT) and Prof. Alvaro Pascual-Leone (Harvard) on a neuromodulation technology that uses electric fields to entrain, non-invasively, oscillatory neural activity.

Nir has a PhD in Neuroscience from Imperial College London. In his PhD Nir and his co-workers, were developing a new type of retinal prosthesis that was based on a genetic expression of a microbial light sensitive ion channel. Nir has MSc in Electromagnetic Engineering from the Technical University of Hamburg-Harburg (TUHH), Germany and BSc in Physics from the Israeli Institute of Technology.

### PUBLICATIONS

- N Grossman, K Nikolic, C Toumazou, P Degenaar (2011). Modeling Study of the Light Stimulation of a Neuron Cell with Channelrhodopsin-2 Mutants. *IEEE Transactions on Biomedical Engineering.*, Vol. 58, 6, 1742–51
- N Grossman, V Pohrer, M Grubb, G T Kennedy, K Nikolic, M A A Neil, M D Dawson, J Burrone, P Degenaar (2010). Multi-site optical excitation using ChR2 and micro-LED array. *J. Neural Eng.*, 7, 16004
- P Degenaar, N Grossman, M A Memon, J Burrone, M Dawson, E Drakakis, M Neil, K Nikolic (2009). Optobionic vision – a new genetically enhanced light on retinal prosthesis. *J. Neural Eng.*, 6, 3, 095007
- N Grossman, A Ovsianikov, A Petrov, M Eich, B Chichkov (2007). Investigation of optical properties of spiral photonic crystals. *Optic Express* 15, 20, 13236–43



## Pau Herrero-Viñas, PhD

### Research focus

Automatic Control for Diabetes Management and Antimicrobial Resistance

### Funding

European Commission

### MOTIVATION

Optimal glucose management is crucial to reduce the risk of complications in diabetes (e.g. blindness, kidney disease and amputations). Recent advances in diabetes technology and mobile technologies open the door to new treatments (e.g. an artificial pancreas) which can revolutionize the treatment of diabetes.

Antimicrobial resistance is a major global threat. We are increasingly seeing patients infected with bacteria for which there are very few antimicrobials that remain effective. To conserve the effectiveness of antimicrobials we need to develop ways to use them more sensibly. New advances on clinical IT infrastructures (e.g. electronic health records) are allowing to collect and analyze big amounts of data in an unprecedented way. This technological revolution is facilitating the development of software tools to support clinicians to prescribe and deliver antibiotics in a more effective way.

### OBJECTIVES

- Development and clinical validation of a safety system for an intelligent glucose management mobile application (PEPPER project).
- Clinical validation of a closed-loop system for automatic glucose control in diabetes (BiAP project).
- Development and clinical validation of a closed-loop system for optimizing antimicrobial therapy in secondary care (REACT project).

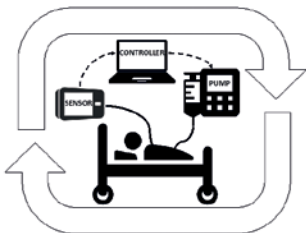

Automated closed-loop antibiotic delivery in a hospital setting (REACT Project)

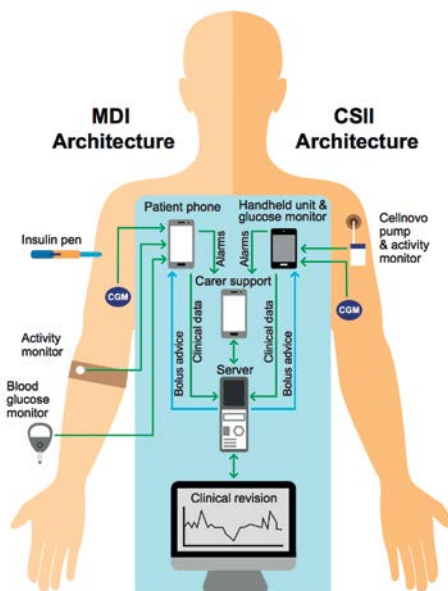

System architecture of the PEPPER system for diabetes management

### RECENT ACHIEVEMENTS

- Mid-term milestone of the H2020 PEPPER project achieved.
- Clinical testing of a safety system for a mobile-based decision support system in diabetes management.
- *In silico* validation of a closed-loop controller for real-time antimicrobial delivery in a hospital setting.
- Organization of the 2nd Artificial intelligence for Diabetes (AID2017) as part of the Artificial Intelligence in Medicine conference (AIME2017). Vienna, Austria, 2017.

### BIOGRAPHY

Pau Herrero-Viñas received the MEng degree in industrial engineering from the University of Girona (Spain) in 2001, and the PhD degree in control engineering from University of Angers (France) in 2006. He then spent one year as a Research Fellow at University of California Santa Barbara (USA), working on an artificial pancreas project. After his stay in California, he spent two years at Sant Pau Hospital in Barcelona (Spain) leading different eHealth projects for the prevention and management of diabetes. He is currently a Research Fellow within the Centre for Bio-inspired Technology at Imperial College London.

### PUBLICATIONS

P Herrero, J Bondia, O Adewuyi, P Pestl, M El-Sharkawy, M Reddy, C Toumazou, N Oliver, P Georgiou. Enhancing automatic closed-loop glucose control in type 1 diabetes with an adaptive meal bolus calculator – in silico evaluation under intra-day variability. *Computer Methods and Programs in Biomedicine* (2017) 146:125–13.

P Herrero, J Bondia, N Oliver, P Georgiou. A coordinated control strategy for insulin and glucagon delivery in type 1 diabetes. *Comput Methods Biomech Biomed Engin* (2017) 20(13):1474-1482.

T M Rawson, E Charani, L S P Moore, P Herrero, J S Baik, A Philip, M Gilchrist, E T Brannigan, P Georgiou, W Hope, A H Holmes. Vancomycin therapy in secondary care; investigating factors that impact therapeutic target attainment. *Journal of Infection* (2017) 74:320–324.

T M Rawson, D O'hare, P Herrero, S Sharma, L Moore, E de Barra, J Roberts, A Gordon, W Hope, P Georgiou, A Cass, A Holmes. Delivering precision antimicrobial therapy through closed-loop control systems. *Journal of Antimicrobial Chemotherapy* (2017) (In Press).



## Nishanth Kulasekeram

### Research focus

To develop low-power microelectronics for a fully implantable peripheral nerve interface for the monitoring and treatment of obesity

### Funding

ERC Synergy (i2MOVE)

### MOTIVATION

Obesity to surpass tobacco as top killer as described in the *New Scientist* issue 10<sup>th</sup> of March 2004. First, obesity is the new smoking. In the 1960s 70% of men smoked, though that is down to around 20% now. Today, two-thirds of adults are either overweight or actually obese. It is a worsening disaster for individuals and their children the NHS, productivity levels and people's personal happiness. In some cases, weight-loss surgery, also called bariatric surgery, is an option. Weight-loss surgery limits the amount of food you're able to comfortably eat or decreases the absorption of food and calories or both. While weight-loss surgery offers the best chance of losing the most weight, it can pose serious risks. However, the latter mentioned risks could be greatly reduced by the inclusion of an intelligent closed loop implant, which is a good alternative to bariatric surgery.

### OBJECTIVES

- To exploit circuit technique researched and developed since July 2014.
- A closed loop integrated circuit solution to aid the monitoring and treatment of obesity.
- To demonstrate the principle in an *in-vivo* environment.

### RECENT ACHIEVEMENT

Modified switch biasing front end amplifiers, which shows an optimal clocking frequency dependent  $1/f$  noise reduction has been characterized across 10 samples and the benefits of using such front end differential amplifiers for neural recording has been exposed to my peers.

I have also developed an integrated circuit to capture and record neural mass activity on a AMS 0.35um low voltage technology.

### BIOGRAPHY

I have spent 12 years in the semiconductor industry prior to joining the Centre of Bio Inspired Technology, here at Imperial College London, in July 2014. Over the past 3 years, since joining, I have developed integrated circuit solutions to aid the detection of CAPs, and mass activity off the sub diaphragmatic vagus nerve. The IC's, fabricated include a multi-channel electrical and PH recording solution. The designs also include a biphasic current stimulator integrated circuit to stimulate the cervical vagus

### PUBLICATIONS

S E Paraskevopoulou, A Eftekhar, N Kulasekeram, C. Toumazou, "A Low-Noise Instrumentation Amplifier with DC Suppression for Recording ENG Signals", *Proc. IEEE EMBS Conference*, 2015.

K B Mirza, N Kulasekeram, C Toumazou Current Feedback Neural Amplifier with Real Time Electrode Offset Suppression *Proc. IEEE MWSCAS Conference* 2017

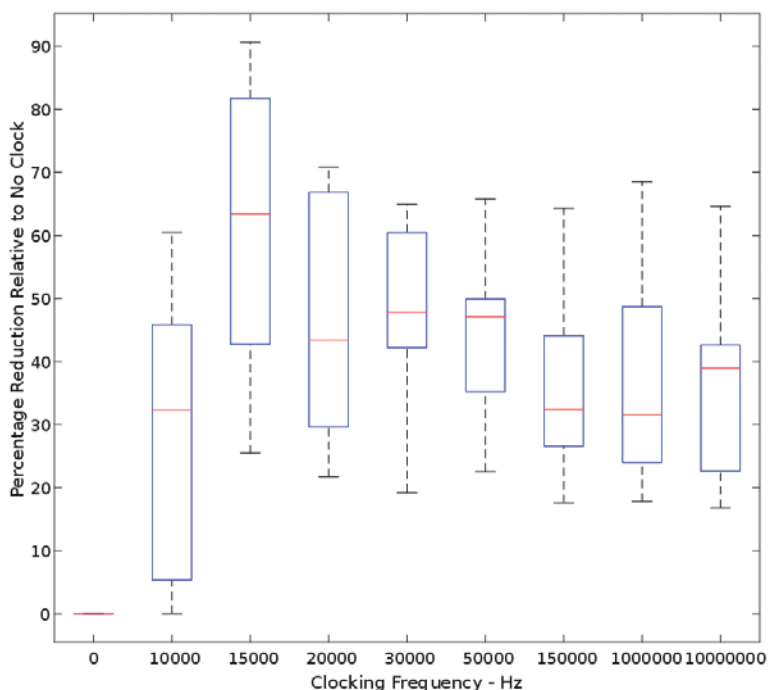

Left: Reduction in flicker noise which is a large percentage of the noise bandwidth for transistors biased in strong inversion as opposed to weak inversion

Below: Recorder front end for capturing neural mass activity and Compound Action Potentials

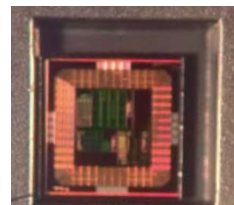



## Yan Liu, PhD

### Research focus

Integrated Neural Microsystems and Neural Interfaces

### Funding

Wellcome Trust and EPSRC (CANDO Project)

### MOTIVATION

My work is in part motivated by the current quest to understand the human brain, developing new tools and applying these to create both next generation brain machine interfaces and therapeutic neural network regulation. Such devices will need to observe the activity of multiple neurons in real time, feedback control with low latency, be chronically stable and be adaptive over time.

### OBJECTIVES

- Design low power, low noise highly integrated circuits for neural interfacing
- Develop advanced schemes for data compression of neural recordings.
- Implement novel recording platform for either *in-vivo* or *in-vitro* study.

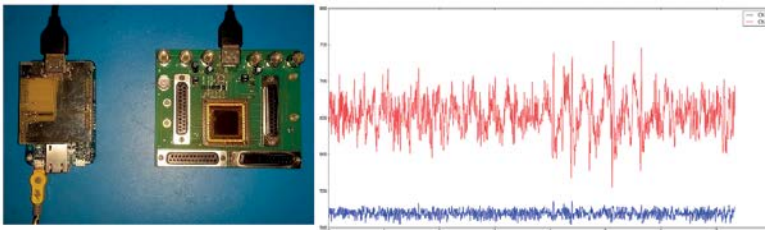

*In-vivo* evaluation of the CANDO platform

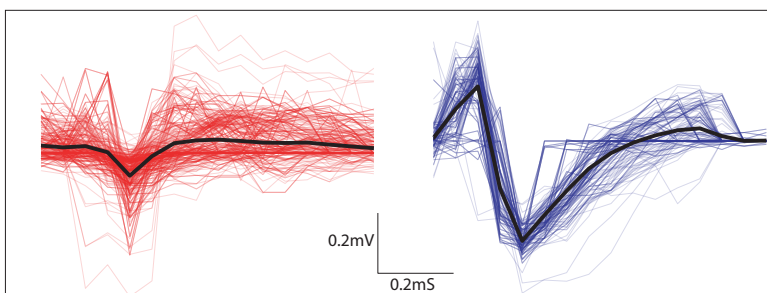
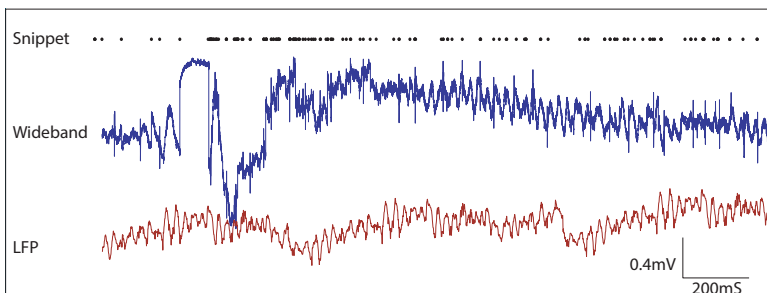

*In-vivo* recording results with neural spike activity extracted.

### RECENT ACHIEVEMENT

In the CANDO project, we have developed a revised design of an optogenetically-enabled closed loop neural probe for regulating neural network activity, involving both neural recording and optical stimulation. The recording function has been evaluated *in-vivo* in rhesus macaque. Further integration has started with collaboration in Newcastle university and UCL.

For the NGNI project, we evaluated a complete system-on-chip system with low noise and low power recording front end and data compression digital logic, which enable activity dependent power consumption and data throughput for large scale recording systems. The electrical and *in-vivo* evaluation demonstrated the functionality.

### BIOGRAPHY

Yan Liu received the B.Eng degree in 2006 from Process Equipment and Control Engineering at Zhejiang University, China, the M.Sc degree in 2007 and Ph.D in 2012 from Electrical and Electronic Engineering at Imperial College London, UK. He is now a research associate in Centre of Bio-inspired technology, Electrical and Electronic Engineering at Imperial College London. His research area includes: CMOS based lab-on-chip devices and platforms, brain machine interface, and novel mixed signal circuits for biomedical applications.

### PUBLICATIONS

Y Liu, S Luan, I Williams, A Rapeaux, T G Constandinou, "A 64-Channel Versatile Neural Recording SoC with Activity Dependent Data Throughput", *IEEE*, pp. 1–12, 2017.

C Gao, S Ghoreishizadeh, Y Liu, T G Constandinou, "On-chip ID generation for multi-node implantable devices using SA-PUF", *Proc. IEEE (ISCAS)*, pp. 678–681, 2017.

M Maslik, Y Liu, T S Lande, T G Constandinou, "A charge-based ultra-low power continuous-time ADC for data driven neural spike processing", *Proc. IEEE*, pp. 1420–1423, 2017.

S S Ghoreishizadeh, D Haci, Y Liu, N Donaldson, T G Constandinou, "Four-Wire Interface ASIC for a Multi-Implant Link", *IEEE*, pp. 1–12, 2017.





## Jesus Rodriguez Manzano, PhD

### Research focus

Engineering solutions for emerging infectious diseases and antimicrobial resistance

### Funding

Wellcome Trust

### MOTIVATION

Emerging infectious diseases and antimicrobial resistance seriously endanger individual and global health, especially in developing countries. Worldwide monitoring is currently lacking and most of the analysis is limited to centralised laboratories, which are dispersed relative to the geographic spread of the population at risk. Current diagnostic tests require complex laboratory procedures and patients have to wait for days to receive the results, therefore it represents a major challenge for point-of-care (POC) diagnostics. My main goal here at CBIT is to develop simple diagnostic platforms and new molecular methods for pathogen identification that can be deployed in limited-resource settings.

### OBJECTIVES

- The development of a lab-on-a-chip diagnostic platform that can be deployed in limited-resource setting.
- The combination of CMOS biosensors with molecular methods to improve speed, sensitivity and resolution of current diagnostic technologies.
- Novel isothermal molecular methods for rapid pathogen identification and SNP detection.

### RECENT ACHIEVEMENT

The 2017 Imperial Confidence in Concept (ICiC) Scheme has awarded the project "Next generation diagnostics for rapid discrimination of Influenza at the point-of-care using Ion-FET digital Quantification on CHIP

(IQ-CHIP)". The aim of this proposal is to create the next generation of biosensors for detection of infectious diseases, which will lead to the development of rapid and ultrasensitive POC tests.

The 2017 CRCE pump-priming collaborative grant scheme has funded the project "A novel lab-on-chip system for detecting residual or recurrent tumour after surgical excision in patient with cervical cancer". In this project we will evaluate the most promising tumour DNA and human papillomavirus biomarkers for cervical cancer diagnosis.

### BIOGRAPHY

After I finished my graduate studies in Microbiology, I enrolled for a Masters degree in Molecular Biology and completed a PhD in Environmental Microbiology and Biotechnology at the University of Barcelona, Spain. In 2012 I moved to the US for a short stay at the University of California, San Diego. Then, I joined the Division of Chemistry and Chemical Engineering at the California Institute of Technology for a three-year postdoctoral position, where I was developing cutting edge point-of-care diagnostic technologies for infectious diseases. My core expertise is situated within the interface of biology and engineering, including bioinformatics, development of low-cost sample preparation methods, innovative molecular tools for detection, quantification and typing of microbial pathogens, microfluidics, isothermal nucleic acid amplification chemistries and digital single-molecule assays.

### PUBLICATIONS

X Fernandez-Cassi, N Timoneda, S Martínez-Puchol, M Rusiñol, J Rodriguez-Manzano, *et al.* "Metagenomics for the study of viruses in urban sewage as a tool for public health surveillance." *Sci Total Environ*, 2017 (in press).

N Moser, J Rodriguez-Manzano, LS Yu, M Kalofonou, S de Mateo, X Li, T Lande Sverre, C Toumazou, P Georgiou. "Live Demonstration: A CMOS-Based ISFET Array for Rapid Diagnosis of the Zika Virus." *Conference Proceedings of the 2017 IEEE International Symposium on Circuits and Systems (ISCAS)*.

RF Ismagilov, J Rodriguez Manzano, M Karymov, *et al.*, "Devices and methods for direct visual detection and readout of single nucleic acid molecules." US Patent WO2017079696A1, 2017.

RF Ismagilov, S Begolo, J Rodriguez Manzano, "Devices and Methods for Autonomous Measurements." US Patent WO2016105508, 2016.

A novel POC diagnostic platform for infectious diseases

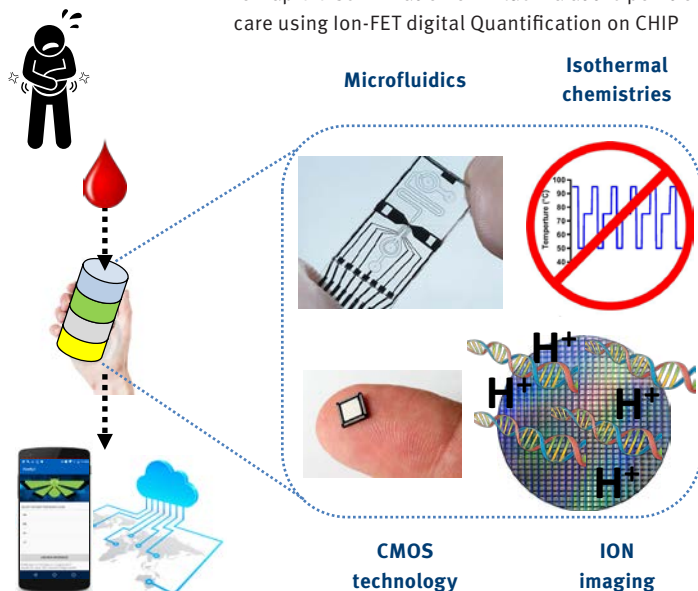



## Sara S Ghoreishizadeh, PhD

### Research focus

Integrated circuit and system design for next-generation bio-sensing medical devices

### Funding

Imperial College Research Fellow

### MOTIVATION

Next-generation implantable and wearable medical devices are emerging to address unmet healthcare needs, particularly those in medical monitoring and diagnostics. Monitoring of metabolites (e.g., glucose, lactate) in human body is of significant importance in health-care and personalised therapy. Despite remarkable advances in electrochemical bio-sensing, the constant need of the sensors for external calibration remains a barrier to their diagnostic potential. My goal is to create biosensing devices that are miniaturised, autonomous and capable of self-calibration. In particular, I propose full-integration and co-design of biosensors with electronics on CMOS IC to achieve this goal.

### OBJECTIVES

- To create highly-sensitive electrochemical biosensors on CMOS IC
- To utilise the advantages of VLSI design to perform biosensor self-calibration
- To demonstrated autonomous Readout IC for wide dynamic range sensor currents

### RECENT ACHIEVEMENT

I designed and demonstrated a novel differential sensing system to eliminate the (glucose) sensor's background current [J1]. We also showed the growth of Platinum nanoparticles on CMOS IC, for the first time, to develop highly-sensitive miniaturised biosensors [J1, Fig.1].

We developed the first prototype of a wireless Smart Orthodontic Bracket for continuous monitoring of pH in the mouth [C1].

We designed a fully-integrated 4-Wire Interface system-on-chip for shared multi-implant power transfer and

full-duplex communication [J2]. I introduced an innovative circuit and algorithms to generate permanent random-IDs during IC fabrication [P1].

### BIOGRAPHY

I received the PhD degree from EPFL in 2015 following the BSc and MSc degrees (both with distinction) from Sharif University of Technology in 2007 and 2009, respectively. I joined CBIT at ICL in 2015 where I am currently a Junior Research Fellow. My research on IC design for biomedical applications has so far led to 27 journal and peer-reviewed conference publications. I have been a Review Committee Member and session chair at IEEE ICECS 2016 and BioCAS 2017 conferences. I am on the editorial board of the Journal of Microelectronics since 2015 and a member of IET, IEEE as well as IEEE CAS, SSC, and EMB societies.

### PUBLICATIONS

- [J1] S S Ghoreishizadeh, I Taurino, G De Micheli, S Carrara, and P Georgiou, "A differential Electrochemical Readout ASIC with Heterogeneous integration of Bio-nano Sensors for Amperometric Sensing", *IEEE Transactions on Biomedical Circuits and Systems (TBCAS)*, Vol 11, No. 5, PP 1148–1159, 2017
- [J2] S S Ghoreishizadeh, D Haci, Y Liu, N Donaldson, and T G Constandinou, "4-Wire Interface ASIC for a Multi-Implant Link", *IEEE Transactions on Circuits and Systems (TCAS-I)*, available online, 2017, DOI: 10.1109/TCSI.2017.2731659
- [P1] S Ghoreishizadeh and T G Constandinou, "On-chip random ID generation," GB Patent (application) 1702623.8, February 2017
- [C1] D Ma, C Mason, S S Ghoreishizadeh, "A wireless system for continuous in-mouth pH sensing," *IEEE international conference on biomedical circuits and systems (BioCAS) 2017*. Best student paper award.

The layout of differential readout IC with heterogeneous integration of bio-nano-sensors on the top metal layer (left). The SEM images of the platinum nanostructure grown on the top metal layer to enhance to sensor sensitivity

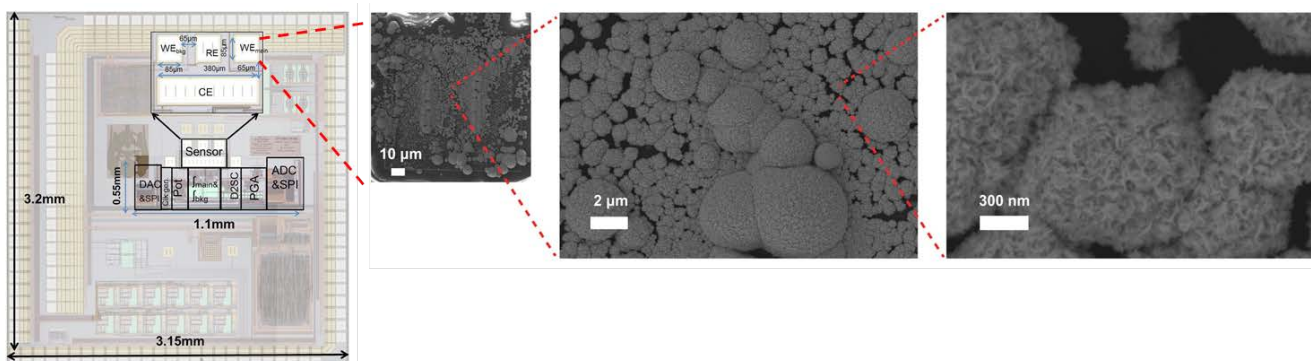



## Laszlo Grand, PhD

### Research focus

*In-vivo* and *in-vitro* platforms for large-scale neurophysiological activity monitoring, stimulation and Parkinson's research

### Funding

EPSRC

### MOTIVATION

Deep Brain Stimulation is a widely used clinical therapeutic method to aid in suppression of Parkinson's disease refractory symptoms and medication reduction. However, clinically approved systems continuously stimulate targeted areas, which might contribute to long-term tissue damage, changes electrode characteristics, depletes battery in 2–5 years and its effect fades away over time. We aim to develop a miniature, implantable and adaptive system, which only stimulates the neural target when triggered by the output algorithm that searches for specific neural patterns brain activity.

### OBJECTIVES

- To develop a closed-loop stimulation system for efficient treatment of Parkinson's disease
- To find efficient biomarkers and algorithms, which can be used for triggering stimulation
- Implementation of Phase-Amplitude coupling algorithm on FPGA first, later on ASIC and validating our system in preclinical setting.

### RECENT ACHIEVEMENT

I have initiated two research projects. The first focuses on Parkinson's disease and aims to develop a miniature,

implantable, closed-loop system for alleviating Parkinsonian symptoms with event based electrical stimulation. We have improved and validated the Phase-Amplitude coupling algorithm, which calculates a potential Parkinsonian neurophysiological biomarker. As a first step we have validated our algorithm with human data recorded intraoperatively by our collaborator at the Johns Hopkins University.

My second project focuses on developing a novel *in-vitro* platform for large-scale neurophysiological activity recording from pluripotent stem cell derived neurons and cardiomyocytes.

### BIOGRAPHY

I received my MSc degree in Computer and Electrical Engineering from the Pázmány Péter Catholic University in Hungary in 2006 and my PhD in Neuroscience from the same University in 2010. My PhD thesis focused on development and characterization of a novel implantable neural probes for *in-vivo* research, which I partly carried out at the University of Michigan and NeuroNexus Technologies. As a postdoctoral fellow of the Laval University in Canada, I performed traumatic brain injury related neurophysiological studies between 2010–2012 before becoming the R&D director of Microprobes for Life Sciences, which focus is implantable neural interfacing technologies. I joined to the Johns Hopkins University as an Investigator in 2013, where I carried out *in-vivo* and *in-vitro* neurophysiological studies on neural circuit development and designed assays for drug testing for pharmaceutical companies. I am an Adjunct Assistant Professor of the Department of Neurology and Neurosurgery of the Johns Hopkins University.

### PUBLICATIONS

- A Moly *et al.*, "Embedded Phase-Amplitude Coupling Based Closed-loop Stimulation for Parkinson's Disease", *Proc. IEEE EMBS Conference*, 2018 (in review).
- K Szostak *et al.*, "Neural Interfaces for Intracortical Recording: Requirements, Fabrication Methods, and Characteristics", *Frontiers of Neuroscience*, 2017 (in review).
- L Grand, *et al.*, "A novel multisite silicon probe for high quality laminar neural recordings", *Sensors and Actuators A-Physics*, vol. 166, no. 1, pp. 14–21, 2011.
- L Grand, *et al.*, "Short and long term biocompatibility of NeuroProbes silicon multielectrodes." *Journal of Neuroscience Methods*, vol. 189, no. 2, pp. 216–29, 2010.

High level steps of the PAC calculation algorithms

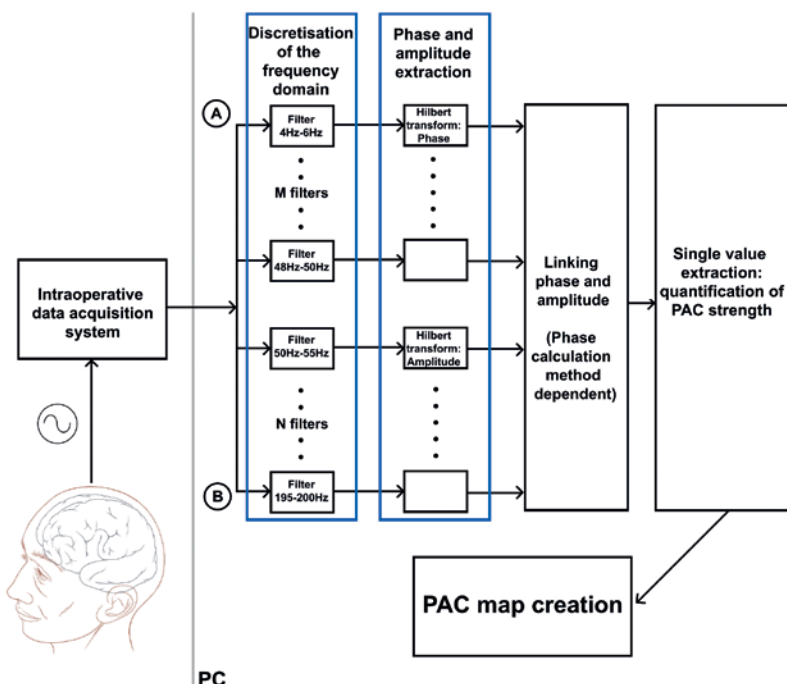



## Mohamed El Sharkawy, PhD

### Research focus

Bio-inspired Systems for Treatment of Diabetes

### Funding

Wellcome Trust

### MOTIVATION

The world health organization (WHO) estimates that more than 180 million people have diabetes worldwide. It predicts that this number will double by 2030. In the year 2005 almost 1.1 million people died from diabetes. If left uncontrolled, diabetes can lead to a number of serious consequences. The Diabetes Control and Complications Trial (DCCT) was a major clinical study that took place in 1993 and showed the benefits of tight glycaemic control [2]. The study involved 1,441 volunteers, ages 13 to 39, with type 1 diabetes and showed that intensive glucose control leads to 76% and 50% risk reduction in eye disease and kidney disease respectively. These results make it clear that technologies that help diabetics manage their blood glucose levels more effectively are of paramount importance.

### OBJECTIVES

My research focuses on the development of a bio-inspired artificial pancreas for tight glycaemic control of blood glucose. The ultimate aim is to have a system that is low power, user friendly and improves on current open loop pump therapy. Sensor accuracy is a major challenge that needs to be addressed for successful realisation of an artificial pancreas.

Using the beta-cell and exploiting the noise improving capability due to gap-junction coupling of multiple cells, my research has shown how glucose sensor accuracy can be improved through a bio-inspired method. Following on from this finding, it is additionally proven that similar robustness due to noise is also achievable when fabricating beta-cells in CMOS through reduction in variation due to mismatch.

### BIOGRAPHY

Mohamed graduated in 2008 from the German University in Cairo, Egypt with Bachelors in Electronics Engineering (BE). Following that in 2009 he graduated



*The Bio-inspired Artificial Pancreas*

from Imperial College London with an MSc in Analogue and Digital Integrated Circuit Design. From 2010 to present he has been involved in the bio-inspired artificial pancreas project as a research assistant and a part time phd student. His interest is mainly focused on developing technologies for type 1 diabetes management.

### RECENT PUBLICATIONS

M El Sharkawy, P Georgiou, "A study of pancreatic cell coupling for improved glucose sensing" *Biomedical Circuits and Systems Conference (BioCAS)*, vol. 16, pp. 556–559, 2014

M Reddy *et al.*, "Feasibility study of a bio-inspired artificial pancreas in adults with type 1 diabetes", *Diabetes technology & therapeutics*, vol. 16, no. 9, pp. 550–557, 2014

### KEY REFERENCES

Jama, "Lifetime benefits and costs of intensive therapy as practiced in the diabetes control and complications trial", *B. DCCT*, vol. 276, pp. 1409–1415, 1996



## Caroline Golden, PhD

### Research focus

Applying DNA-based dietary protocols to improve public health and patient outcomes in type 2 diabetes, and cancer, and determining the efficacy of vagal nerve stimulation (VNS) therapy on gastric cancer tumorigenesis

### Funding

ERC Synergy (i2Move)

There are a number of feedback loops between the brain and the stomach, that form the highly interconnected network of the nervous system and the endocrinology system of the gut, also known as the brain-gut axis. In our clinical trial, we will harness the influence of the nervous system on gastric tissue to improve outcomes for patients with gastric cancer.

### MOTIVATION

The emerging field of rapid genetic testing has unleashed the potential for this technology to be used for the benefit of public health. By tailoring dietary guidelines to the DNA of the individual, there is the potential to improve medical conditions such as diabetes, and the macro- and micro-nutrient profile of a healthy individual to increase longevity and quality of life.

Gastric cancer is the fourth leading cause of cancer-related deaths in the world. Building on preliminary results in animal studies, our aim is to apply VNS to reduce tumorigenesis, improve quality of life above standard care (D2-gastrectomy), and prolong lifespan in gastric cancer patients.

### OBJECTIVES

- To determine the efficacy of a DNA-based diet and nudge theory in improving the glucose tolerance of prediabetic individuals.
- To apply VNS therapy to patients with gastric cancer to improve patient outcomes.
- To form a Nudgeomics Centre of research at Imperial that will tackle nutrition, cancer, and obesity through the use of a DNA-based diet and nudge theory.

### RECENT ACHIEVEMENT

Since joining the Centre for Bio-Inspired Technology (CBIT) in May, I have been researching the most influential areas in medicine to which a DNA-based diet may be applied. This has culminated helping to bring two clinical trials into inception; (i) The impact of personalised DNA-based nutrition on impaired glucose regulation in prediabetic individuals, (ii) Using VNS to treat patients with gastric cancer to improve patient outcomes. Furthermore, I've led the grant proposal submission on a collaboration with Prof. George Hanna, to examine nutrigenomic connections with cancer.

### BIOGRAPHY

Caroline completed her B. Eng in Biomedical Engineering at the National University of Ireland Galway (2011). She interned in Stanford University, where she worked on algorithms for detecting metal artifact reduction in CT images under the supervision of Prof. Norbert Pelc. She completed her M. Sc in Bioengineering with Neurotechnology at Imperial College London (2012), and her PhD under the supervision of Dr. Paul Chadderton (2016). Her PhD research focused on the neural correlates of working memory in the anterior cingulate cortex of rodents, and the pharmacological manipulation of those circuits using a serotonergic agonist. She is currently working as a Research Associate at CBIT.

### PUBLICATIONS

C T Golden, J Afonso, M T C Brown, A Renart, S Royer, and P Chadderton. (2017) Population dynamics in the mouse anterior cingulate cortex during working memory. *Manuscript in preparation*

C T Golden, M T C Brown, R Carhart-Harris, D Lucaci, and P Chadderton (2017), The influence of psilocybin on prefrontal cortical circuits. *Manuscript in preparation*.

C T Golden, D Nandi, P Bain, and N Yousif, "Deep brain stimulation induced effects in a network of ventral intermediate neurons," *BMC Neuroscience* 2013 14:1, vol. 14, no. 1, p. P427, Jul. 2013.

C T Golden, S R Mazin, F E Boas, G Tye, P Ghanouni, G Gold, M Sofilos, and N J Pelc, "A comparison of four algorithms for metal artifact reduction in CT imaging," presented at the SPIE Medical Imaging, 2011, vol. 7961, pp. 79612Y-79612Y-12.

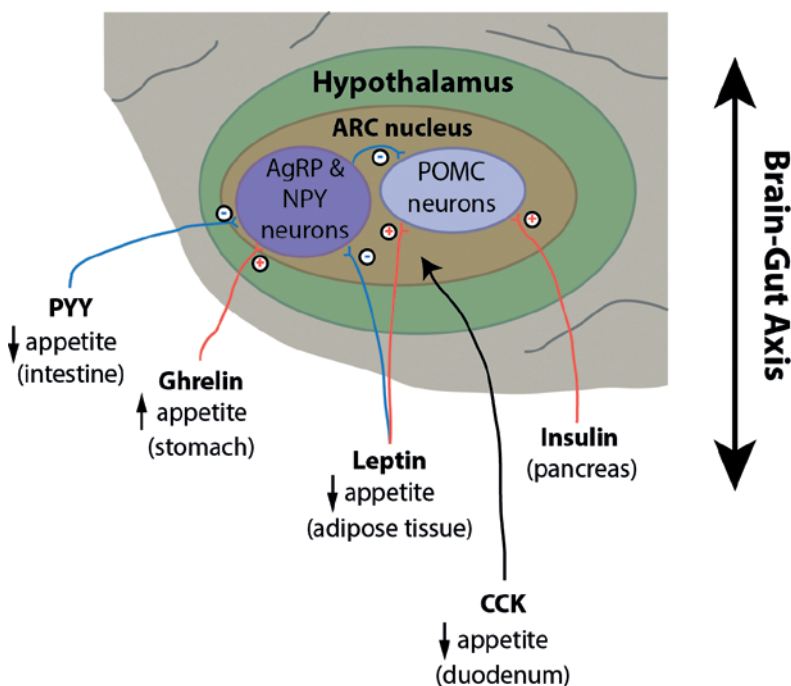



## Melpomeni Kalofonou, PhD

### Research focus

Microchip technology and informatics for cancer diagnostics and precision monitoring

### Funding

EPSRC

### MOTIVATION

With the rapid progression of Lab-on-Chip technology for Point-of-Care diagnostics, we have seen a convergence of engineering and sensing technologies, with an emphasis on precision monitoring. For types of cancer with a high risk of post-treatment recurrence, the need for access to targeted molecular profiling systems has become a top priority, aiming for more precise monitoring of cancer progression, while preventing the development of drug resistance.

Development of novel cancer monitoring technology has been the focus of my research, with the latest outcomes to have led to a rapid detection method of breast cancer mutations which in combination with multi-sensor arrays will lead to the next generation of blood-based breast cancer monitoring tests. This is a multidisciplinary project in collaboration with medicine, towards a fast and low-cost system for targeted breast cancer profiling, with the ability to analyse and classify generated data in real-time, allowing for better stratification of breast cancer treatment.

### OBJECTIVES

- Development and experimental validation of liquid-biopsy based DNA detection methods for breast cancer specific markers.
- Integration and miniaturisation of Lab-on-Chip sensing technology for monitoring of tumour derived circulating-free genetic markers in blood samples.
- Application of machine learning algorithms for classification of cancer biomarkers and development of risk prediction systems.

*Detection of circulating tumour DNA (ctDNA) breast cancer mutations using sample-to-result microchip technology – Cancer relapse/Resistance*

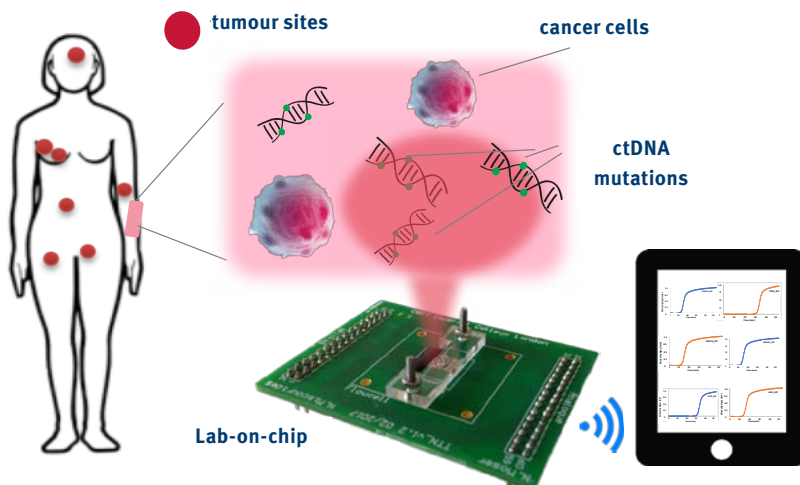

### RECENT ACHIEVEMENT

Some highlights over the last year include further validation of breast cancer markers in collaboration with Prof. Charles Coombes and Prof. Simak Ali, Faculty of Medicine – Imperial College London and Prof. Jacqui Shaw, Translational Cancer Genetics – University of Leicester, demonstration of a fully working multi-sensor platform at IEEE ISCAS 2017, Baltimore, USA, invited talks on ‘Could a microchip detect early signs of breast cancer’ at Microsoft London as part of the industrial outreach seminar ‘Hackathon 2017’, World Precision Medicine Congress 2017 and at the public engagement event ‘Pint of Science 2017 – Our body – Medicine, Human Biology, Health’.

### BIOGRAPHY

Dr Melpomeni Kalofonou is Cancer Technology Research Lead within the Centre. Graduating with an MSc, PhD in Biomedical Engineering, Imperial College London, she has conducted pioneering work in cancer technology, having innovated methods for detection of cancer specific biomarkers using DNA microchip technology. She is leading research on the development of the first microchip-based breast cancer monitoring test (Mi-CARE), integrating chemical sensors with cancer gene-specific assays, targeting circulating tumour DNA markers. Dr Kalofonou is a member of the IEEE, IET, ESMO and the IEEE Biomedical Circuits and Systems Technical Committee (BioCAS TC), promoting biomedical engineering research in cancer diagnostics and precision in treatment.

### PUBLICATIONS

M Khwaja, M Kalofonou and C Toumazou, “A Deep Learning System for Differentiation of Cancer Types based on DNA Methylation,” 2017. Manuscript in preparation

M Khwaja, M Kalofonou and C Toumazou, “A Deep Belief Network system for prediction of DNA Methylation,” *IEEE Biomedical Circuits and Systems Conference (BioCAS)*, 2017.

A Koutsos, M Kalofonou, M Sohbaty and C Toumazou, “Epigenetic-IC: A fully integrated sensing platform for epigenetic reaction monitoring,” *IEEE International Symposium on Circuits and Systems (ISCAS)*, 2016.



## Lieuwe B Leene, PhD

### Research focus

Intelligent Integrated System on Chip for Brain Machine Interfaces

### Funding

EPSRC (ENGIN project - Empowering Next Generation Implantable Neural Interfaces)

### MOTIVATION

Current trends in neuroscience and commercially available biomedical electronics have demonstrated great promise for delivering better health care. As a result, there is a growing interest to distribute millimetre size bio-signal sensors throughout the human body to greatly improve therapeutic and diagnostic capabilities of today's healthcare. This effort raises new challenges beside the conventional focus on power and noise of electronics. For instance, decoding activity from the central nervous system will necessitate highly adaptive capabilities that can interpret physiological markers in an effective and distributed manner. Any of these futuristic capabilities have yet to be accommodated in implantable devices currently available.

Moving towards this goal requires a number of cutting edge technologies to be seamlessly integrated together.

### OBJECTIVES

- Develop fully integrated sensing systems for bio-signal acquisition that are scalable and have distributed processing capabilities.

- Utilise multi modal and mixed signal processing techniques to realise ultra efficient signal decoding with commercially available CMOS technologies.
- Model instrumentation systems in relation to their resource requirements & dependencies to allow high level analytic optimisation strategies.

### RECENT ACHIEVEMENT

Over the past year I have worked on asynchronous processing of time encoded signals for implantable devices. These techniques seem very promising for significantly reducing the power required to process neural signal because of the intermittent activity. In this context, I have proposed several fundamental processing structures and techniques that can be used as building blocks for more complex systems. This is currently being applied to the development of an autonomous millimetre sized neural recording probe that will make future brain-machine interfaces more capable.

### BIOGRAPHY

Lieuwe Leene recently completed his PhD at Imperial College London specialising in developing integrated CMOS circuits for implantable healthcare devices. He received his BEng. Electronic Engineering from the Hong Kong University of Science and Technology and his MSc Analogue and Digital Integrated Circuit Design from Imperial College London. Lieuwe then joined the NGNI Neural Interfaces group at the Center for Bio-Inspired Technology as PhD student. Currently he holds a post-doc position at Imperial with the NGNI group.

### PUBLICATIONS

L B Leene, T G Constandinou, "A 0.016<sup>2</sup> 12 b  $\Delta\Sigma$ SAR with 14fJ/conv. for Ultra Low Power Biosensor Arrays", *IEEE Transactions on Circuits and Systems I: Regular Papers*, vol. 64, no. 10, pp. 2655–2665, 2017.

L B Leene, T G Constandinou, "Time Domain Processing Techniques Using Ring Oscillator-Based Filter Structures", *IEEE Transactions on Circuits and Systems I: Regular Papers*, pp. 1–10, 2017.

L B Leene, T G Constandinou, "A 0.5V time-domain instrumentation circuit with clocked and unlocked  $\Delta\Sigma$  operation", *Proc. IEEE International Symposium on Circuits and Systems (ISCAS)*, pp. 2619–4, 2017.

L B Leene, T G Constandinou, "A 2.7uW/MIPS, 0.88GOPS/mm<sup>2</sup> Distributed Processor for Implantable Brain Machine Interfaces", *Proc. IEEE Biomedical Circuits and Systems (BioCAS) Conference*, pp. 360–363, 2016.

The PIKACHU testing platform used for characterising time-domain sensing topologies and asynchronous processing techniques of PWM signals

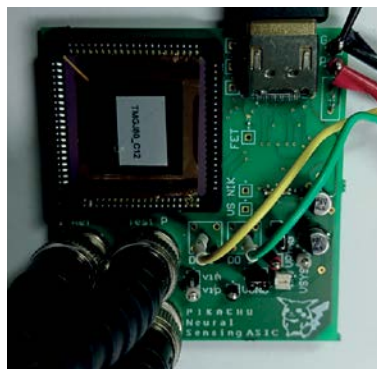

The PIKACHU prototype which was fabricated using a commercially available TSMC 65nm CMOS LP-MS-RF technology (1P9M6X1Z1URDL)

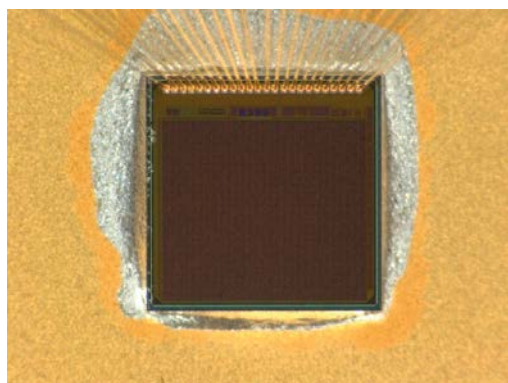



## Kezhi Li, PhD

**Research focus**  
Machine Learning in Diabetes Management

**Funding**  
EPSRC

### MOTIVATION

My position focuses on conducting research in machine learning for Diabetes as part of a high profile project called ARISES funded by the EPSRC Intelligent technologies to support collaborative care initiative.

Specifically, we try to design sensor fusion algorithms which can extract meaningful information from wearable technology and implement machine learning algorithms which can quantify lifestyle metrics which can inform diabetes management.

### OBJECTIVES

- Understand the mechanics of Diabetes management
- Understand existing machine learning techniques in Diabetes
- Develop algorithms extract meaningful information and make useful prediction or suggestions

### RECENT ACHIEVEMENT

I joined the group at the beginning of August. In the last one month, I had a deeper understanding of diabetes management, and conducted a comprehensive literature review over the existing machine learning algorithms in this field. Several problems considered as the first questions which deep learning can potentially solve were investigated. Corresponding algorithms are under development.

### BIOGRAPHY

Kezhi Li is a senior Research Associate at Bio-Inspired Technology Center, Imperial College London (ICL). He obtained the PhD degree at ICL in Feb, 2013, and B. Eng. from University of Science and Technology of China, in 2008, respectively. His research interests are machine learning, statistical signal processing and their applications in diabetes management, quantum tomography and imaging systems. Prior to this position, he had positions as a research scientist at Medical Research Council (MRC), a research associate at University of Cambridge, a research fellow at Royal Institute of Technology (KTH) in Stockholm and a research assistant at Microsoft Research Asia.

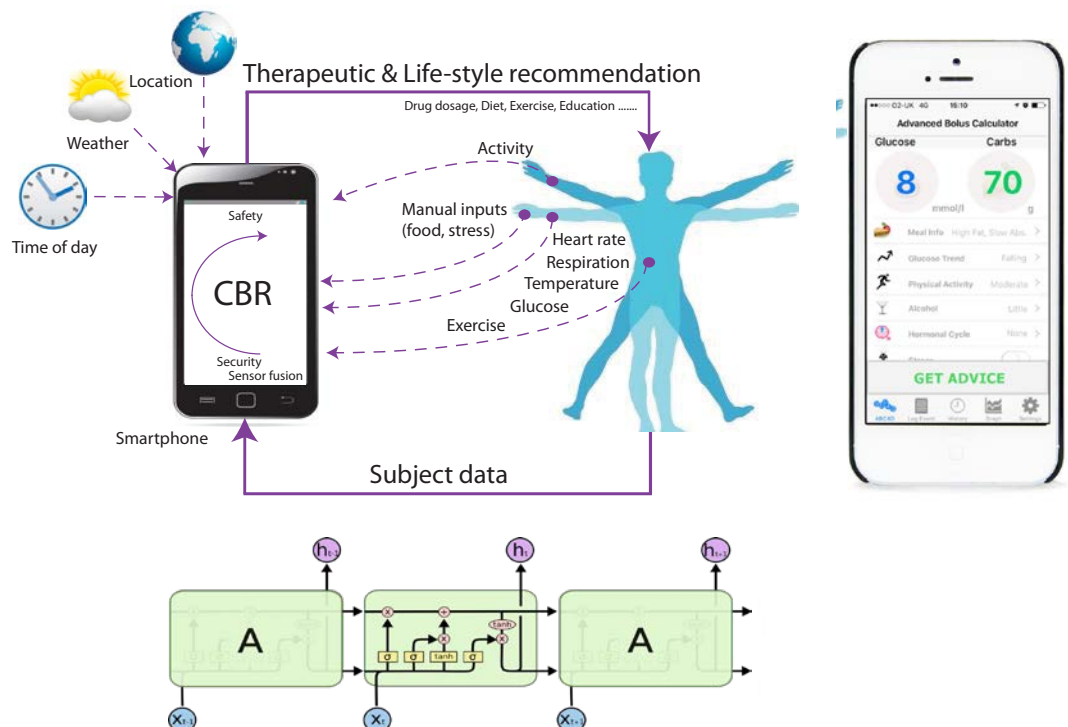





## Chengyuan Liu, PhD

### Research focus

Robust Control and its Application in Diabetes Management

### Funding

European Commission

### MOTIVATION

Safety and accuracy are the most important features of a decision support system in diabetes management. Improving the performance of the decision support system is not only applying the latest control methods into the system, but also making appropriate choice and efficient modifications of the control algorithms.

The research is conducted for the purpose of providing more accurate glucose forecasting and more efficient and secure insulin therapy advice for the subjects with type 1 diabetes.

### OBJECTIVES

- Improve the performance of the Safety System for PEEPER project
- Develop more efficient glucose forecasting algorithm
- Develop a model predictive control method for glucose control

### RECENT ACHIEVEMENT

- Improved the performance of the glucose forecasting algorithm in the safety system of PEEPER project, with a paper publication is in the making.
- Keep delivering updated code of the safety system for PEEPER project.

### BIOGRAPHY

Chengyuan Liu received the B.Eng. degree on Automation from the Ocean University of China Qingdao College, China, in 2012, and the Ph.D. degree on Robust Control from Imperial College London, U.K., in 2017. Currently, she is a Research Associate at the Department of Electrical and Electronic Engineering, Imperial College London. Her Research interests include robust control, optimization, predictive control, and their application.

### PUBLICATIONS

Liu C, Jaimoukha IM. The computation of full-complexity polytopic robust control invariant sets. *Proceedings of IEEE Conference on Decision and Control*, 2015; 6233–6238.

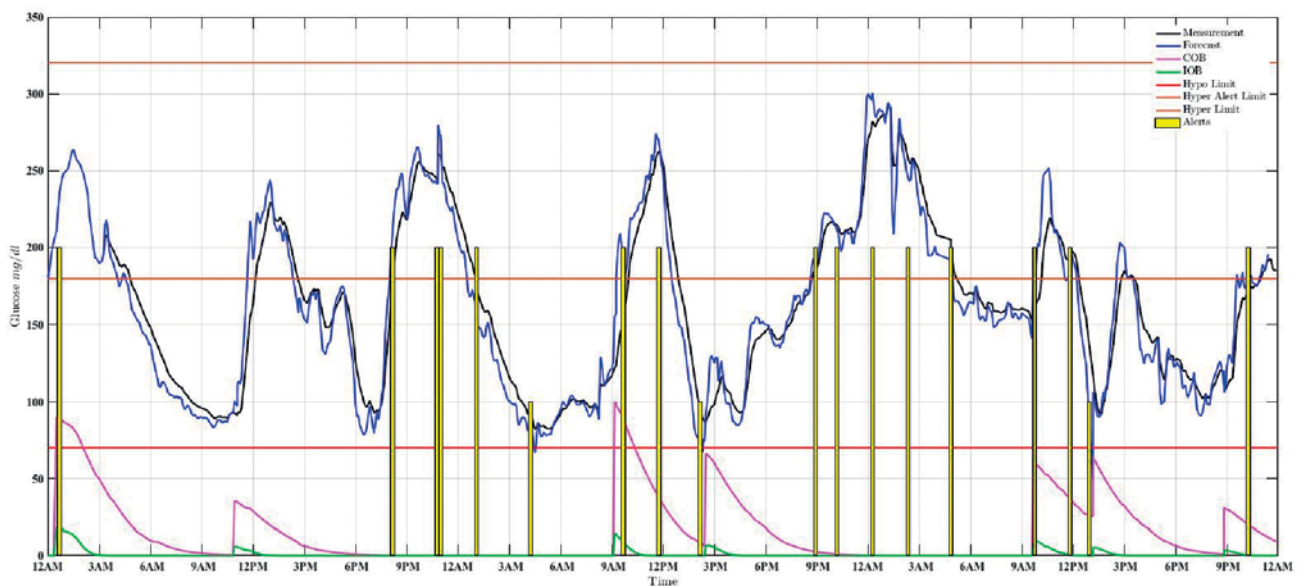

Glucose forecasting and safety management



## Sara de Mateo Lopez, PhD

### Research focus

Integration of isothermal nucleic acid amplification chemistries with ISFET-based pH measurement in CMOS technology – development of a novel method for DNA methylation quantification.

### Funding

ERC Synergy (izMove)

### MOTIVATION

The need of rapid and reliable analysis of nucleic acids linked to non-optical readout methods has grown lately. In our center (CBIT), engineers have developed a chip that integrates real time, label-free amplification and detection of nucleic acids using pH-sensing complementary metal-oxide semiconductors (CMOS) technology through ion-sensitive field effect transistor (ISFET) sensors.

On the other side, the use of epigenetic marks, such as DNA methylation, as biomarkers for disease detection has gained medical attention including infertility and cancer. The motivation of my research is to develop a novel methodology that can be implemented in our in-house technology for the quantification of DNA methylation from different biological samples to create a full lab-on-chip platform to enable point-of-care testing.

### OBJECTIVES

- Test new isothermal nucleic acid chemistries that can be implemented in our in-house chips.
- Develop a novel methodology for DNA methylation quantification using isothermal nucleic acid amplification from different biological samples.
- Implement the novel developed method for DNA methylation quantification in our in-house chips that integrate a major number of ISFET sensors and eventually help create a lab-on-chip platform that will be used as a diagnostic tool for point-of care.

### RECENT ACHIEVEMENT

We have applied for different grants to get funds to develop our main research goals such as the EPSRC Impact Acceleration Early Stage grant (awaiting results). I participated in a demo paper and I am also

involved in several projects that aim to develop a Lab-on-chip platform for the detection and quantification of infectious diseases.

### BIOGRAPHY

I obtained my Biology degree in 2006 from the Autonomous University of Barcelona and performed my PhD at the University of Barcelona, Spain. During my PhD thesis, I characterized the human sperm proteome of the whole cell and from isolated nuclei from infertile patients and controls. In 2011, I moved to California for a postdoctoral position in the University of California, Irvine, United States of America with the purpose of describing the murine sperm metabolome and in 2016 I started a Research Associate position at ICL. I am currently developing novel chemistries for the detection and quantification of nucleic acids by isothermal amplification methods.

### PUBLICATIONS AND KEY REFERENCES

C Toumazou, L M Shepherd, S C Reed, G I Chen, A Patel, D M Garner, C J Wang, C P Ou, K Amin-Desai, P Athanasiou, H Bai, I M Brizido, B Caldwell, D Coomber-Alford, P Georgiou, K S Jordan, J C Joyce, M La Mura, D Morley, S Sathyavvruthan, S. Temelso, R E Thomas, L Zhang, “Simultaneous DNA amplification and detection using a pH-sensing semiconductor system”, *Nature Methods*, vol. 10(7):641–646, 2013.

M Kalofonou, C Toumazou, “Semiconductor technology for early detection of DNA methylation for cancer: From concept to practice”, *Sensors and Actuators B: Chemical*, vol. 178, 572–580, 2013.

N Moser, J Rodriguez-Manzano, L-S Yu, M Kalofonou, S de Mateo, X Li, T Sverre Lande, C Toumazou, P Georgiou, “Live Demonstration: A CMOS-Based ISFET Array for Rapid Diagnosis of the Zika Virus”, *IEEE International Symposium on Circuits and Systems (ISCAS)*, 2017.

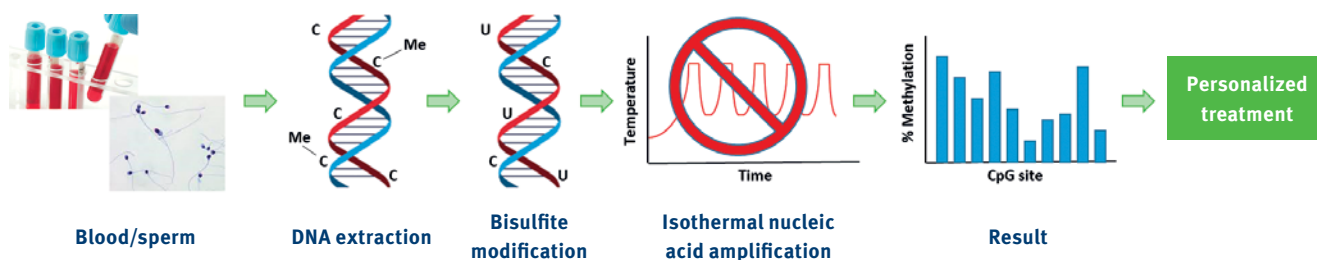

*Novel DNA methylation quantification method for different biological samples to be used at point-of-care*



## Song Luan, PhD

### Research focus

Integrated neural microsystems and neural interfaces

### Funding

EPSRC (NGNI/iPROBE projects)

### MOTIVATION

As electronic systems keep shrinking in size and improving in functionality, more and more applications are now focusing on vital sign monitoring. E.g. heart rate, blood pressure, etc. There is currently a tremendous drive to develop new enabling technologies for neuroscience. This will pave the way to a new breed of neural interfaces and prosthetic devices that will restore natural function. The underlying, ultimate motivation is however to improve the quality of life of individuals with neural damage and dysfunction.

### OBJECTIVES

- Develop a scalable miniature system that is capable of real-time hardware spike sorting thus reducing data-rate reduction for wireless communication and other real-time applications;

- Create a platform capable of recording at least 1k channels of neural signals at different areas of brain to allow investigation of neural circuitry.
- Provide chronic *in-vivo* recording solutions for laboratories.

### RECENT ACHIEVEMENT

NGNI system has been successfully tested in several 24-hour sessions recording multiple neurons in freely behaving untethered animals. The recording shows consistent spike shapes and real-time spike sorted events reflects expected changes in neural activity during awake behavior and sleep cycles. The next generation ASIC with lower power yet powerful function has also been successfully tested *in-vivo*. Based on this new powerful chip, a platform with 768-channel recording has been implemented. More advanced neural recording devices for different areas of neuroscience research will be developed in the near future.

### BIOGRAPHY

Dr Song Luan received the B.Sc. and B.Eng from Fudan University, China, and University of Birmingham, U.K. in 2005 respectively and M.Sc. in analogue and digital integrated circuit design and PhD degrees in biomedical microelectronics engineering from Imperial College London, U.K. in 2010 and 2014 respectively. He works as a research associate in the electrical and electronic engineering department. His current research interests include chronic implantable neural interfaces and miniature ASIC based systems for novel biomedical applications. He is also interested in mixed-signal microelectronic system and low-power microelectronics.

### PUBLICATIONS

- S Luan, I Williams, M Maslik, Y Liu, *et al.*, “Compact Standalone Platform for Neural Recording with Real-Time Spike Sorting and Data Logging”, *Journal of Neural Engineering*, 2017 (in review).
- Y Liu, S Luan, I Williams, A Rapeaux, T G Constandinou, “A 64-channel versatile neural recording SoC with activity dependent data throughput”, *IEEE Transactions on Biomedical Circuits and Systems*, 2017.
- S Luan, Y Liu, I Williams, *et al.*, “An Event-Driven SoC for Neural Recording”, Proc. IEEE Biomedical Circuits and Systems (BioCAS) Conference, pp. 404–407, 2016.
- S Luan, I Williams, F de Carvalho, A Jackson, R Quian Quiroga, T G Constandinou, “Next Generation Neural Interfaces for low-power multichannel spike sorting”, *FENS Forum of Neuroscience*, 2016.

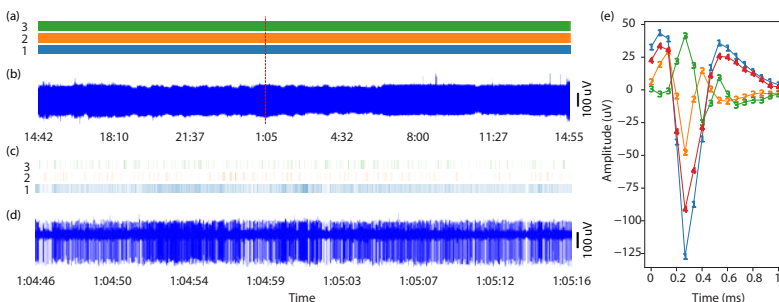

Extracellular neural recording showing sorted spike events (in real-time) during a 24-hour *in-vivo* recording session in freely behaving animal

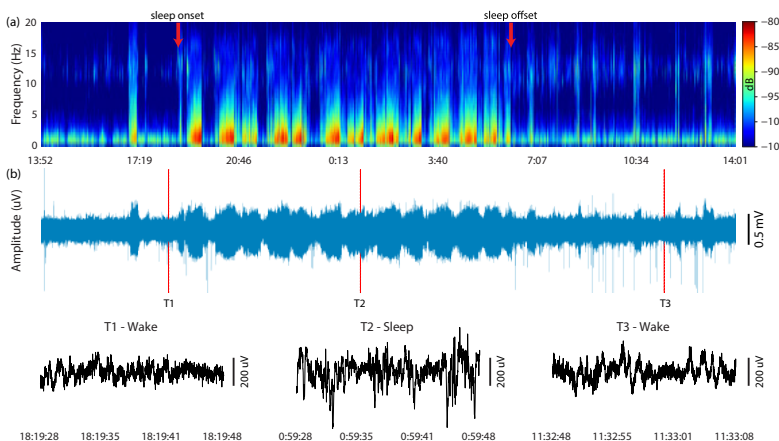

(a) Spectrogram with sleep onset and cessation annotated in local field potentials (LFP) during a 24-hour period; (b) Recorded LFP signal with magnified insets during awake and sleep



## Katarzyna Szostak

### Research focus

Micropackaging and integration for the new generation of intracortical brain recording electrodes

### Funding

EPSRC (ENGINI project - Empowering Next Generation Implantable Neural Interfaces)

### MOTIVATION

People have always been eager to decode the mysteries of the brain and learn about the nature of neural conditions. Nowadays, within the interdisciplinary field of Brain-Machine-Interfaces various miniaturized devices are developed with the purpose of observing brain activity in high detail, thus opening the potential to improve the understanding of neuronal processes or treat various neurological conditions.

The major challenge left is to scale down the implant technology. Developing future brain implants that will be simple, autonomous, and chronically reliable is a complex task requiring to fulfill highly demanding requirements in biocompatibility, electronic integration and mechanical behavior and could be achieved with careful selection materials and methods for packaging and fabrication.

### OBJECTIVES

- Design and microengineering of microsystem package for the innovative chip-scale, autonomous neural interfacing implants
- Physical system integration ensuring chronic performance and hermeticity of all co-components
- Adaptation of various fabrication technologies and materials for use in neural interfacing solutions

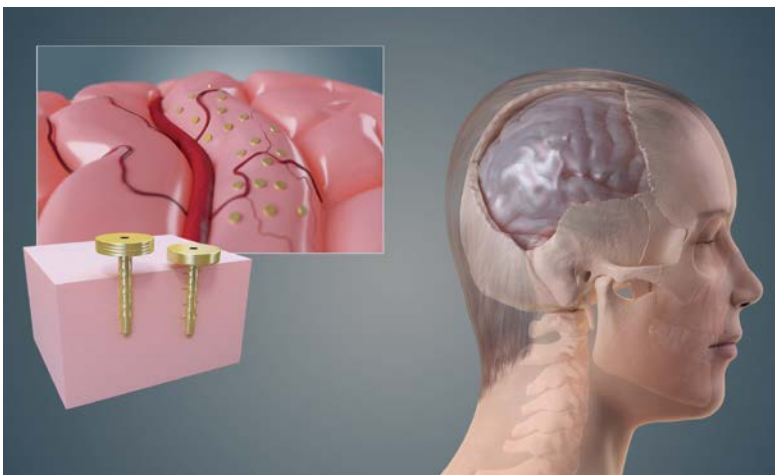

The design concept of standalone new generation ENGINI probes

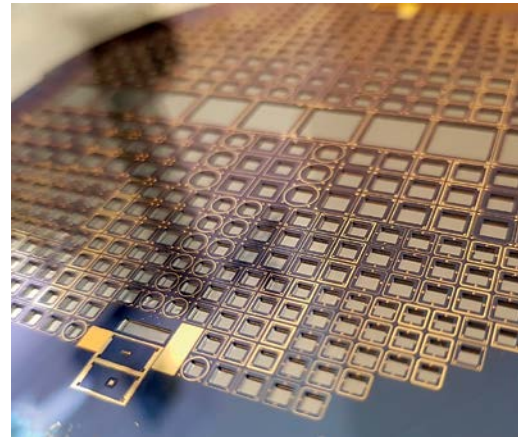

Silicon wafer with series of cavities surrounded by gold-tin eutectic before hermetic sealing.

### RECENT ACHIEVEMENT

Recently Kasia has worked on proving usability of gold-tin eutectic joints for the formation of hermetic micropackage of neural probes. In addition, Kasia is working towards assembly of novel double-interposer based neural probe which integrates microwire recording with on-chip electronics and wireless communication in single package.

### BIOGRAPHY

Kasia obtained both her BSc. (Hons) in Electronics and Telecommunication (2011) and Masters (Distinction) in Microsystems, Electronics and Photonics (2012) from Wroclaw University of Technology, Poland. Both her dissertations were focused on different aspects of microfabrication- silicon etching processes and wafer bonding. Katarzyna's research interests are focused on microfabrication technologies, she worked for research institutes and private companies across Europe (Poland, Germany, Belgium, and Finland) developing new processes, sensors and clean-room based solutions. In August 2015 Katarzyna has joined Neural Interfaces team at Imperial College London where she is currently working on the new generation of the implantable neural interfaces within ENGINI project.

### PUBLICATIONS

K M Szostak, F Mazza, M Maslik, L B Leene, P Feng, TG Constandinou, "Microwire-CMOS integration of mm-scale neural probes for chronic local field potential recording," *Proc. IEEE Biomedical Circuits and Systems (BioCAS) Conference*, pp. 492– 495, 2017.



## Huan Wang, PhD

### Research focus

Microfabrication of sensors and devices for medical application

### Funding

Wellcome Trust

### MOTIVATION

'Small Is Beautiful', is particularly true for implantable medical devices for a number of reasons. Nano/micro sized wireless implantable medical devices can not only provide 24/7 continuous body condition monitoring for further effective diagnosis, reduce patients' pain and improve patients' life quality, but also can reduce healthcare costs.

With the technological advancement in semiconductor industry, it is possible to fabricate implantable pressure sensors with dimensions of the order of a few hundreds of micrometers. However, achieving desirable device sensitivity and stability is very challenging due to miniaturization. Therefore, it is essential to develop novel fabrication techniques and explore new materials to improve device performance.

### OBJECTIVES

- Exploring new materials and design microfabrication techniques for assembly and integration of implantable medical devices in cleanroom.
- Improving microfabrication processes and upscale to a wafer level fabrication.
- Conducting finite element analysis for designing implantable medical devices with COMSOL Multiphysics.

### RECENT ACHIEVEMENT

- Building a computer model in COMSOL to study a miniature pressure sensor and extract design parameters for microfabrication.
- Contribution to the development of a project (Development of a novel angioplasty balloon catheter) by designing laser cut Nitinol tubes and balloon modification.
- The fabrication of a new type of AlN thin film acoustic waver resonators at wafer level.

### BIOGRAPHY

I have done my PhD in nanofabrication and characterisation at London Centre for Nanotechnology in University College London. My research was in the area of nanowires based NEMES, especially nanomechanical resonators for mass sensing application. In February 2014, I joined Imperial College London to work on fabrication and characterisation of ultra-sensitive thin film implantable pressure sensors and medical devices. During this time, I have been broadening my skills in microfabrication, finite element analysis as well as implantable medical devices.

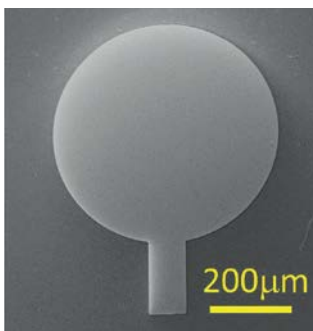

SEM image of top-view of the AlN thin film acoustic wave sensor

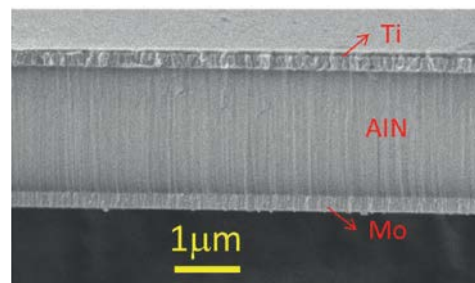

SEM image of cross-section of the AlN thin film acoustic wave sensor

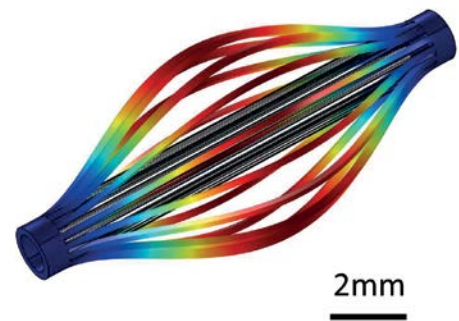

COMSOL Multiphysics simulation image of Nitinol as part of a catheter tip at a vibration mode



## Krzysztof Wildner, PhD

### Research focus

Selective peripheral nerve stimulation

### Funding

ERC Synergy (i2MOVE)

### MOTIVATION

Close integration of technical devices with the peripheral nervous system certainly will lead to breakthroughs in areas of prosthetics and neurorehabilitation. This technology is constantly developing through decades. Techniques of neural recording and stimulation are well established, however, in-depth understanding of how to precisely control excitation or blocking the neural activity along nerves is essential to make further progress in the field. Especially development of new selective stimulation methods is highly desired.

### OBJECTIVES

My goal is to enhance my skills in peripheral nerve stimulation and recording. I have joined i2MOVE team in May 2017 with the plan to establish the vagus nerve stimulation protocol for closed loop system for obesity treatment.



A PCB platform for testing the multichannel pH and CAP recording chip.

### BIOGRAPHY

I have received M.Sc. degree in Automatic Control and Robotics in January 2009 (Warsaw University of Technology, Poland), followed by PhD (Faculty of Mechatronics, WUT) in the field of Biocybernetics and Biomedical Engineering in 2015. Since 2009 I have been involved in teaching: first as a part of my duties as a PhD candidate, next as a teaching and research assistant and from 2015 as a lecturer. I am lecturing and leading laboratory classes closely related to functional electrical stimulation, fundamentals of neuro-muscular system architecture and EMG applications in biomedical engineering.

### KEY REFERENCES

K Wildner, R Pasniczek, M Wladzinski, B Grobelski, D Pawelczak. "Artificial neurotisation by the means of FES", *12th International Conference on Global Research and Education*, Sofia, September 2013.

M Wladzinski, K Wildner, S Cygan, *et al.* "A New Method for Tissue Impedance Spectrometry and Its Initial Application *in vivo*", in: *Recent Technological and Scientific Advances Mechatronics 2013, 2014*, Springer, ISBN 978-3-319-02293-2, pp. 833–838,

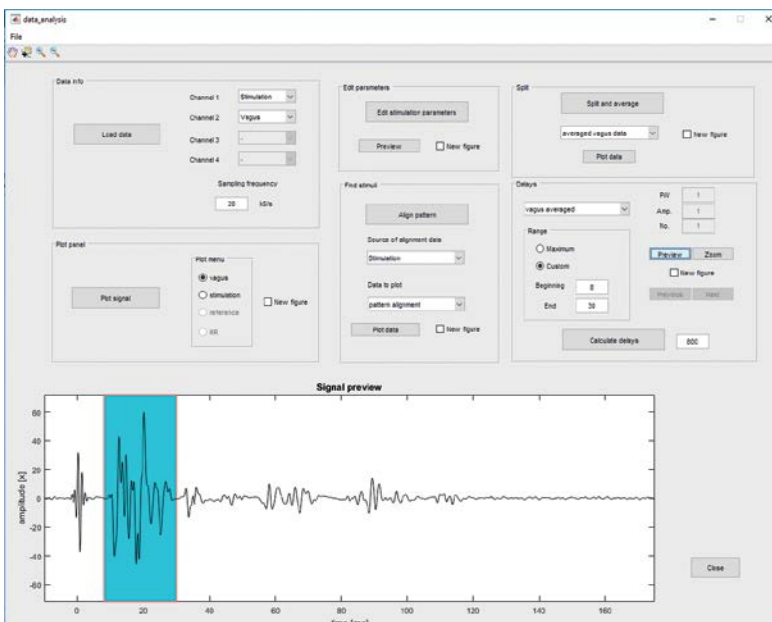

Software for analysis CAP latency variation due to repetitive stimulation



## Ian Williams, PhD

### Research focus

Sensory feedback for upper limb prosthetics

### Funding

EPSRC (Senseback project)

### MOTIVATION

Advanced upper limb prosthetics are becoming increasingly capable and prevalent; however, amputees struggle to utilise even a fraction of that capability in the real world and must constantly look at the prosthesis in order to use it effectively. A key reason for this limited control and the need for visual monitoring is that the prosthesis is insensate – providing no tactile or proprioceptive feedback. This means that the control is open loop and the prosthesis will always remain a tool attached to the body rather than becoming an extension of the body itself.

### OBJECTIVES

Our research aims to develop technology to improve prosthetic limb control - providing artificial proprioceptive and tactile neural feedback from an upper limb prosthesis. By selectively stimulating sensory neurons remaining in the peripheral nerves of the limb stump we aim to enable closed loop control of the limb (mirroring normal limb function). This should ultimately enable the limb to be operated with greater dexterity and without visually monitoring it.

To achieve this, we are collaborating with a number of other UK universities (as part of the Senseback project) to develop flexible intraneural electrodes, miniaturised high performance stimulation & recording electronics, and models of neural signals in the human hand.

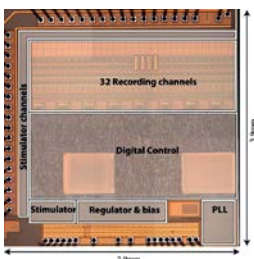

In-vivo research platform under development for evaluating enabling technologies for sensory feedback

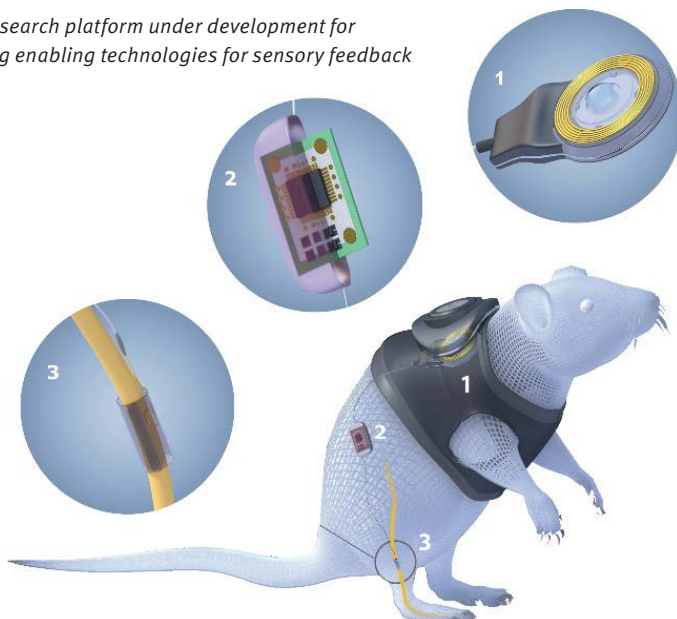

### RECENT ACHIEVEMENTS

2017 has seen the successful 24-hour testing in primates of our miniature NGNI v1 neural recording headstage which features realtime on-node spike sorting. Over the coming year we hope to make these headstages more widely available to neuroscience laboratories.

Over the past year we have also successfully taped-out the Senseback ASIC which provides a 32-channel bidirectional interface (stimulating and recording) to peripheral nerves. Manufacturing is underway to deploy this ASIC into an implantable device and demonstrate it chronically in-vivo.

### BIOGRAPHY

Ian Williams received the M.Eng. degree in electronic engineering from Edinburgh University, UK, in 2004. From 2004 to 2010 he worked in a number of project management and research related roles for the UK Ministry of Defence. In 2014 he completed his Ph.D. in Electronic Engineering at Imperial College London, UK. His research interests include brain-machine interfaces and his doctoral research focused on developing a neural proprioceptive prosthesis for upper limb amputees.

### RECENT PUBLICATIONS

I Williams, A Rapeaux, Y Liu, S Luan, T G Constandinou, "A 32-Channel Bidirectional Neural/EMG Interface with on-Chip Spike Detection for Sensorimotor Feedback", *Proc. IEEE Biomedical Circuits and Systems (BioCAS) Conference*, pp. 528–531, 2016.

I Williams, S Luan, A Jackson and T G Constandinou. "A Scalable 32 Channel Neural Recording and Real-time FPGA Based Spike Sorting System", *Proc. IEEE Biomedical Circuits and Systems (BioCAS) Conference*, 2015.

S Luan, I Williams, T G Constandinou, K Nikolic. "Neuromodulation: present and emerging methods". *Frontiers in Neuroengineering*, Vol. 7, 2014.

I Williams and T G Constandinou. "An energy-efficient, dynamic voltage scaling neural stimulator for a proprioceptive prosthesis". *IEEE Trans. Biomedical Circuits and Systems*, Vol. 7. No. 2, pp. 129–139, 2013.



## Betty Ling-Shan Yu, PhD

### Research focus

Engineering Rapid and Sensitive Electronic Diagnostics for Infectious Diseases

### Funding

EPSRC

### MOTIVATION

Dengue and Zika are members of the flavivirus family of arthropod-borne viruses. Given shared ecology and mosquito vectors, Zika is emerging in areas with endemic dengue virus transmission. Immunity studies indicate that dengue shows substantial cross-reaction to Zika and increases the chances of Zika infection, posing a rising global public health threat. Current diagnostic technologies take place in centralised laboratory and are usually expensive, time-consuming and requiring specialist equipment and personnel. Continued emergence of dengue and Zika viruses, coupled with a lack of effective global surveillance, raises the need for a quantitative rapid, sample-to-answer diagnostic device. We therefore aim to develop an integrated and innovative diagnostic device, deployable in a wide range of healthcare settings for populations suffering from epidemic diseases. We report the molecular detection and quantification of 4 serotypes of dengue and Zika viruses by our lab-on-chip platform. Experiments were conducted with a real-time PCR instrument and the platform simultaneously. Time to positive was achieved from 10 to 40 mins from  $10^5$  to  $10^1$  copies per reaction, confirming both rapid detection and sensitivity. Our next step is to validate on chip and start clinical trials in Taiwan and Thailand.

### OBJECTIVES

- To establish a genomic database and customised bioinformatics pipeline for target pathogens
- To develop the a point-of-care device with isothermal detection chemistry and CMOS based lab-on-chip technology
- To report surveillance data in real-time

### BIOGRAPHY

Ling-Shan Yu is a new research associate in Centre for Bio-inspired Technology. She received her B.S (Hons) from National Taiwan University and her MSc and PhD in Life Science from Imperial College London in 2016. She was awarded a Taiwanese scholarship in 2011 and outstanding performance PhD student scholarship in life science in Imperial College London from 2013-2015. This year, she received a fellowship to continue her research in CBIT, sponsored by Taiwan and UK governments. Her areas of expertise are bioinformatics, phylogenetic analysis and developing molecular methods for virus detection. Her latest research has proposed and focused on developing a point-of-care device for diagnostic infectious disease.

### KEY REFERENCES

T Notomi, H Okayama, H Masubuchi *et al.*, "Loop-mediated isothermal amplification of DNA", *Nucleic acids research*, 2000.

C Toumazou, P Georgiou *et al.*, "Simultaneous DNA amplification and detection using a pH-sensing semiconductor system" *Nature methods*, 2013.

### RELEVANT RECENT REFERENCES

Nicolas Moser, Jesus Rodriguez-Manzano, Ling-Shan Yu, Melpomeni Kalofonou, Sara de Mateo, Xiaoxiang Li, Tor Sverre Lande, Christofer Toumazou and Pantelis Georgiou. "Live demonstration: A COMS-Based ISFET Array for rapid diagnostic of Zika virus" *ISCAS*, 2017

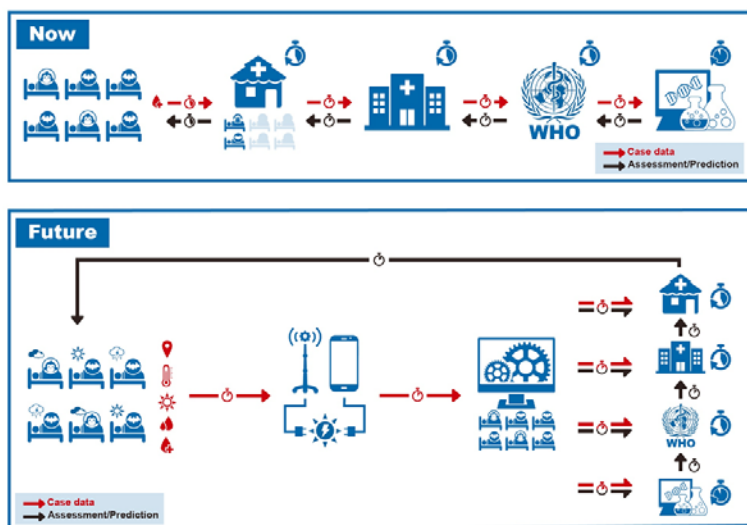

An illustration showing the current method of data collection and transmission for pathogen surveillance and our proposed method





## Longfang Zou, PhD

### Research focus

Wireless transmission for Implanted Medical Devices

### Funding

Wellcome Trust

### MOTIVATION

Implanted medical devices for monitoring, diagnostic and therapeutic purposes have been proven to significantly improve patient's symptoms and quality of life at reduced costs. Wireless communication between implanted medical device and exterior equipment is the most preferred method to eliminate percutaneous cable which is prone to infection and limits patient mobility. Antennas are critical components to ensure effective wireless transmission between implanted and external devices via the highly lossy body tissues. Design of implantable and wearable antennas poses a unique set of challenges such as radiation efficiency, minimization, biocompatibility, integrability, insulation, unobtrusiveness and ergonomics.

### OBJECTIVES

- Development of implantable and wearable antennas to provide robust and bidirectional link between the implanted medical devices and external instruments
- Characterization in animal and human trials
- Optimization of ergonomics

### RECENT ACHIEVEMENT

- New breathable, flexible foams and conductive textiles have been used to design ergonomic wearable antennas to improve comfortability.
- Implantable antennas have been designed with focusing on minimization, mechanical stability, repeatability, reproducibility and insulation.
- Using existing medical devices such as stent and occluder as antenna is under investigation to add additional values of these devices.
- A spin out company was formed to commercialise the research project of Automatic Blood Pressure Monitoring

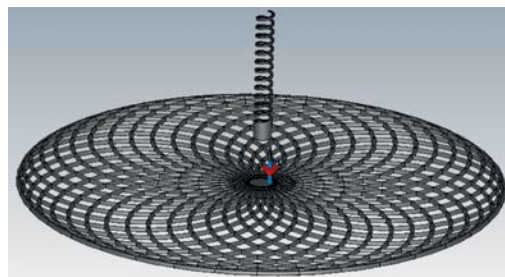

Occluder antenna

### BIOGRAPHY

Dr Longfang Zou received the Bachelor's degree in electrical and electronic engineering from University of Electronic Science and Technology of China, in 1999 and the Master and PhD degree in electrical and electronic engineering from The University of Adelaide, Australia in 2009 and 2013, respectively. He worked at the University of Bristol prior to joining the Centre of Bio-inspired Technology, Imperial College London in 2014. His research interests include antennas, antenna arrays, computational electromagnetics and biomedical devices.

### PUBLICATIONS AND KEY

C Zou, P Gutruf, W Withayachumnankul, L Zou, M Bhaskaran, S Sriram, C Fumeaux, "Nanoscale TiO<sub>2</sub> dielectric resonator absorbers" *Optics Letters* 41(15), 3391–3394, 2016.

C Fumeaux, C Zou, D Headland, S Nirantar, P Gutruf, L Zou, M Bhaskaran, S Sriram, W Withayachumnankul, "Terahertz and optical dielectric resonator antennas: Potential and challenges for efficient designs", *10th European Conference on Antennas and Propagation (EuCAP)*, 10-15 April, Davos, Switzerland, pp. 99–102, 2016. (Invited)

C Zou, P Gutruf, W Withayachumnankul, L Zou, M Bhaskaran, S Sriram, C Fumeaux, "Dielectric Resonator Metasurfaces at Visible Wavelengths", *International Conference on Nanoscience and Nanotechnology (ICONN) 2016*, 7–11 February, Canberra, Australia, 2016.



## Nur Ahmadi

### Research focus

Local Field Potential (LFP) Decoding for Brain-Machine Interfaces

### Supervisors

Dr Timothy Constandinou and Dr Christos Bouganis

### Funding

Lembaga Pengelola Dana Pendidikan (LPDP)

### MOTIVATION

There are millions of people worldwide suffering from paralysis due to neurological disorders such as spinal cord injury (SCI) and amyotrophic lateral sclerosis (ALS). To restore the lost motor function, brain-machine interface (BMI) systems that can control external devices by using brain activity alone have been proposed. Spike-based BMIs have been successfully demonstrated for controlling external devices such as robotic arm or computer cursor. However, clinically viable translation of spike-based BMIs faces two major challenges: stability of spike signal and high power consumption. Local field potential (LFP) offers attractive properties of long-term signal stability and low-frequency content. The use of LFP as signal source for decoding method may improve the reliability and longevity of BMI system.

### OBJECTIVES

- To extract meaningful features from LFPs for effective biofeedback-based BMIs;
- To develop LFP-based decoding algorithm for BMIs;
- To design an efficient hardware implementation of LFP decoding method.

### RECENT ACHIEVEMENT

Neuronal firing rates are features extracted from the brain signal that significantly encode information about hand kinematics (e.g. position, velocity). We recently developed a new method to extract the firing rate features from single trial sequence of spikes (i.e. spike train). The proposed method, referred to as Bayesian adaptive kernel smoother (BAKS), has shown good performance on synthetic and real neural data compared to other established methods. The BAKS thus has potential to provide better single trial statistical analysis in neuroscience and BMI research.

### BIOGRAPHY

Nur received the B.Eng. degree in Electrical Engineering from Bandung Institute of Technology (ITB), Indonesia, in 2011 and the M.Eng. degree in Communication and Integrated Systems from Tokyo Institute of Technology, Japan, in 2013. He then worked as a research and teaching assistant at the Microelectronics Centre and School of Electrical Engineering and Informatics, ITB, for 2.5 years. Currently, he is working toward Ph.D. degree at the Next-Generation Neural Interface (NGNI) research group, within the Centre for Bio-inspired Technology, Imperial College London.

### RECENT PUBLICATIONS

N Ahmadi, T G Constandinou, C Bouganis, "Estimation of neuronal firing rate using Bayesian Adaptive Kernel Smoother (BAKS)", *bioRxiv* 204818; doi: <https://doi.org/10.1101/204818>, 2017

### KEY REFERENCES

A Jackson, T M Hall, "Decoding local field potentials for neural interfaces" *IEEE Trans. on Neural Systems and Rehabilitation Eng.*, 2016.

T M Hall, K Nazarpour, A Jackson, "Real-time estimation and biofeedback of single-neuron firing rates using local field potentials.", *Nature Communications*, vol. 5, p. 5462, 2014.

S D Stavisky, J C Kao, P Nuyujukian, S I Ryu, and K V Shenoy, "A high performing brain-machine interface driven by low-frequency local field potentials alone and together with spikes.", *Journal of Neural Engineering*, vol. 12, no. 3, p. 036009, 2015.

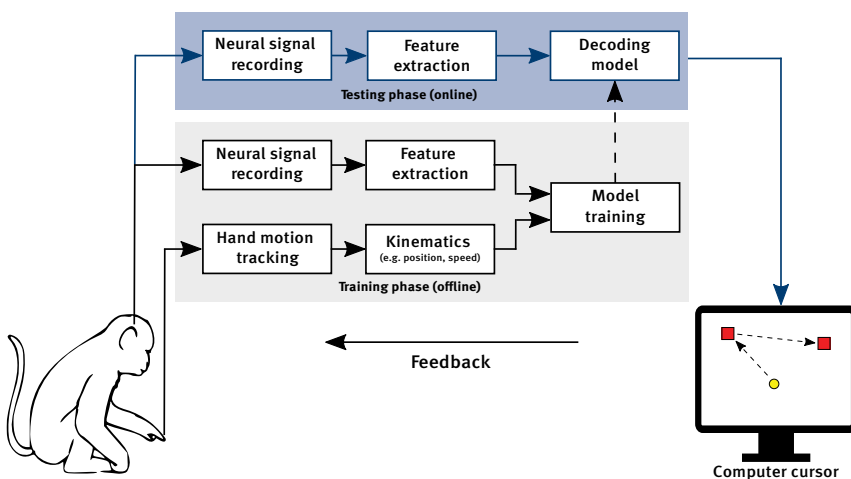

Phases of brain-machine interface (BMI) experiment



## Chih Han Chen

### Research focus

Expert systems for personalized decisions based on genetics

### Supervisor

Professor Chris Toumazou

### MOTIVATION

The rise of personalised diets is due to the emergence of Nutri-genetics and genetic tests services. However, the recommendation system is far from mature to provide personalised food suggestion to consumers for daily usage. The main barrier of connecting genetic information to personalised diets is the complexity of data and the scalability of the applied systems. Aiming to cross such barriers and provide direct applications, our research has focus on building expert system to collect big data from various sources and provide recommendations for better daily decisions

### OBJECTIVE

- Personalized Recommendation based on genetics, Machine learning applications, Artificial Intelligence agent frameworks

### RECENT ACHIEVEMENT

We have built a practical application of expert systems with database for providing personalised grocery recommendations based on genetics.

### BIOGRAPHY

Chih-Han Chen received the M.Sc. degree in electronic engineering with business management from King's College London, London, U.K, and the M.Sc. degree in analog and digital integrated circuit design from Imperial College London, London, U.K, where he is currently pursuing the Ph.D. degree at the Centre for Bio-Inspired Technology, Imperial College London, with a focus on expert systems for personalised decision based on genetics. Chih-Han's research is mainly on expert system, personalised decisions, genomic applications, AI agent with deep learning.

### PUBLICATIONS AND KEY REFERENCES

“PERSON-Personalised Expert Recommendation System for Optimised Nutrition” for publication in the *IEEE Transactions on Biomedical Circuits and Systems*, accepted on 20th of September 2017

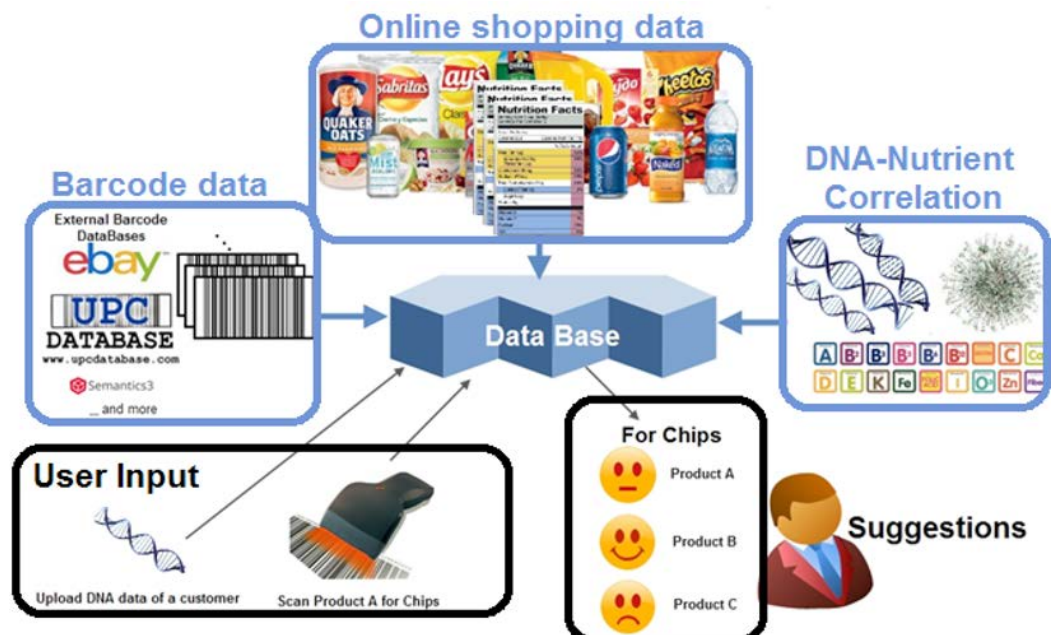

The Expert system for personalised product recommendation



## John S M Daniels

### Research focus

Towards the development of an adaptive, real-time, intelligent system to enhance diabetes management

### Supervisor

Dr Pantelis Georgiou

### Funding

EPSRC

### MOTIVATION

The International Diabetes Federation estimates that 415 million people are living with diabetes in 2015. Given that this number is expected to rise to 615 million in 2050, diabetes is one of the most pressing issues that needs to be urgently addressed in our world today.

Radically increased computing capabilities along with the proliferation in improved sensor technology provide the resources necessary to minimise the complications that arise from living with diabetes. Consequently, the initiative is to develop a robust decision support system to improve management of glucose levels considering a comprehensive range of physiological variables.

### OBJECTIVES

- To develop a robust wearable system for the initial phase of data collection from patients.
- To undertake trials to evaluate effectiveness of BiAP system in managing diabetes in a home setting.

### RECENT ACHIEVEMENT

In the last 12 months: of the BiAP handheld device has been completed and is ready to be used in the coming home trials. This has also included input in an investigation study to determine relevant physiological data to glucose variability in diabetes patients.

### BIOGRAPHY

John received his M.Eng (Hons) in Electrical and Electronic Engineering with Management in 2015 from Imperial College London. Having completed an individual project in his final year on the topic of glucose control for patients in critical care, he joined the Centre for Bio-inspired Technology as a Research Assistant to work on the bio-inspired artificial pancreas project for the home. He is currently involved in the ARISES project to develop an adaptive, real-time intelligent system for diabetes management.

### KEY REFERENCES

- M Reddy, P Herrero, M El-Sharkawy, P Pesl, N Jugnee, H Thomson, D Pavitt, C Toumazou, D Johnston, P Georgiou, N Oliver. "Feasibility study of a bio-inspired artificial pancreas in adults with type 1 diabetes", *Diabetes technology & therapeutics*, vol. 16, no. 9, pp. 550–557, 2014
- M Reddy, P Herrero, M El-Sharkawy, P Pesl, N Jugnee, D Pavitt, IF Goddard, G Alberti, C Toumazou, D Johnston, P Georgiou, N Oliver. "Metabolic Control With the Bio-inspired Artificial Pancreas in Adults With Type 1 Diabetes A 24-Hour Randomized Controlled Crossover Study", *Journal of Diabetes Science and Technology Therapeutics*, 2015

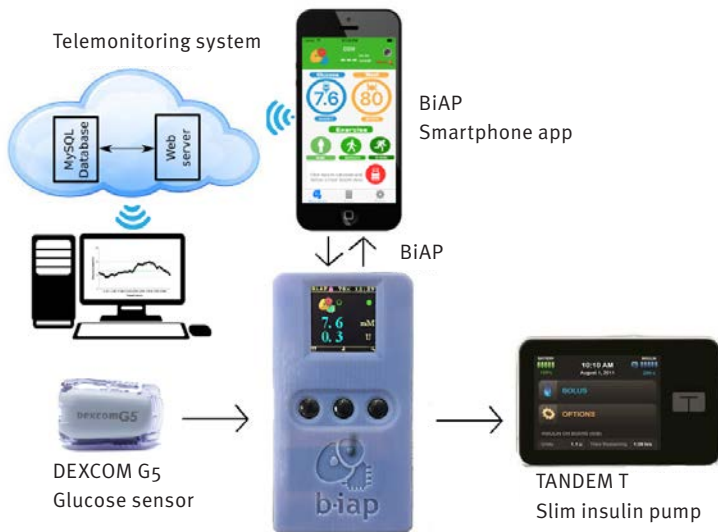

BiAP system for the Home with Adaptive Meal Bolusing

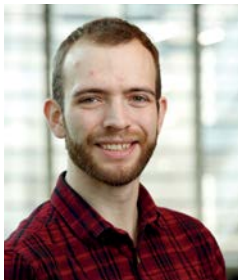

## Matthew Douthwaite

### Research focus

Ultra-low power electronics for wearable electrochemical sensing

### Supervisor

Dr Pantelis Georgiou

### Funding

EPSRC Centre for Doctoral Training in High Performance Embedded and Distributed Systems (HiPEDS)

### MOTIVATION

To obtain a greater insight into the body, physicians and sports scientists often carry out blood tests, which provides indicators on health and fitness. This technique however, results in only a snapshot of the current state of health and is relatively invasive. It has long been known that many of these indicators are also contained in other, more accessible bio-fluids such as saliva and sweat.

This research aims to use CMOS electronics and integrated electrochemical sensors to develop a system for carrying out chemical analysis on the body. By improving robustness, power consumption and size, such devices will facilitate continuous, non-invasive analysis of body chemistry.

### OBJECTIVES

- Us -time changes of ion concentrations in sweat.
- Push the boundaries of low-power electrochemical sensing to improve feasibility of the on-body devices.
- Incorporate on-body electrochemical sensing into existing wearable devices to create a multi-modal approach to health and sport monitoring.

### RECENT ACHIEVEMENT

Over the past year we have manufactured and tested a CMOS ISFET (ion sensitive field effect transistor) array which can measure changes in pH whilst consuming just  $6\mu\text{W}$  of power, and as a result can be powered by body heat using an array of thermoelectric generators as well as other sources of harvested energy.

The integrated circuit provides a proof-of-concept for ISFET based low-power wearable chemical sensing and will be demonstrated at IEEE Bio Circuits and Systems and IEEE Sensors.

### BIOGRAPHY

Matthew Douthwaite (S'14) received the M.Eng. degree in Electrical and Electronic Engineering and the M.Res. degree in advanced computing from Imperial College London (ICL), London, U.K., in 2015 and 2016, respectively. He is currently pursuing the Ph.D. degree with the EPSRC Centre for Doctoral Training in High Performance Embedded and Distributed Systems, within the Centre for Bio-Inspired Technology. His research interests include the design of ultra low power bio-inspired analogue integrated circuits, particularly for wearable applications and energy harvesting.

### PUBLICATIONS

M Douthwaite, E Koutsos, D C Yates, P D Mitcheson and P Georgiou, "A Thermally Powered ISFET Array for On-Body pH Measurement," in *IEEE Transactions on Biomedical Circuits and Systems*, vol. PP, no. 99, pp. 1–11.

M Douthwaite, N Moser, E Koutsos, D Yates, P Mitcheson and P Georgiou, "A CMOS ISFET array for wearable thermoelectrically powered perspiration analysis," *2016 IEEE Biomedical Circuits and Systems Conference (BioCAS)*, Shanghai, 2016, pp. 54–57.

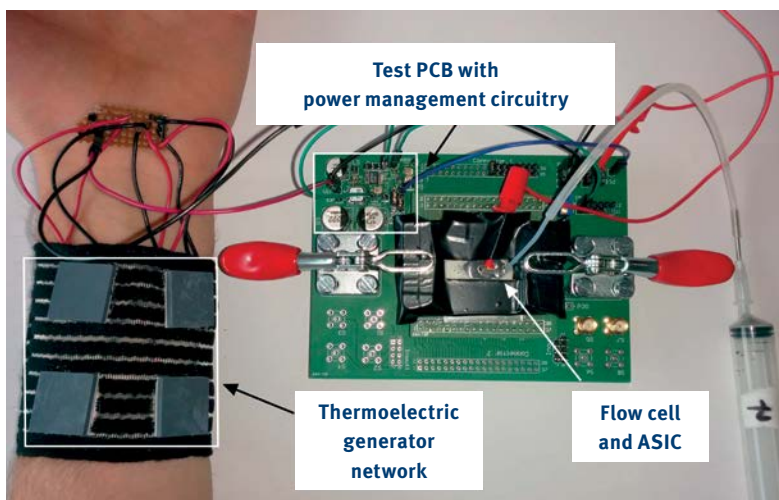

A bench-top demonstration of the thermally powered chemically sensitive application specific integrated circuit (ASIC), powered by an array of generators worn on the wrist and with a target solution injected into a flow cell clamped on top of the IC

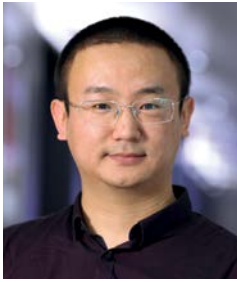

## Peilong Feng

### Research focus

Completely wireless infrastructure for distributed mm-sized neural implants

### Supervisor

Dr Timothy Constandinou

### MOTIVATION

Implantable neural interfaces have the potential to bring many benefits for individuals that have for example been paralyzed and regain lost ability. This technology also provides a powerful investigative tool for neuroscience for exploring how brain works and for understanding disease. My work focuses on developing a low-power and ultra-compact implantable wireless neural interface for power delivery and data communication.

### OBJECTIVES

- Optimize the configuration of distributed implants by making a trade-off between power efficiency, communication bandwidth, location and orientation;
- Develop electronic circuits for energy management including the primary side and the secondary one so that power can be efficiently transferred and utilized;
- Develop distributed data links formed by many independent and bidirectional channels.

### RECENT ACHIEVEMENT

My work over the past year has focused on investigating mm-sized inductive links by developing analytical models, and optimising design through electromagnetic simulation software. A series of mm-sized on-chip coils have been designed and fabricated both in-house, and using standard CMOS

technology for wireless power transmission. An integrated circuit with a high efficiency, autonomous power management system has been designed and fabricated in 0.35 micron CMOS technology.

### BIOGRAPHY

Peilong Feng received the B.E. degree in electrical engineering from the Henan Polytechnic University, China, in 2011, the M.S. degree in microelectronic systems design from University of Southampton, UK, in 2012, and the M.S. degree in analogue and digital integrated circuit design from Imperial College London, UK, in 2015. He is currently pursuing the Ph.D. degree in the Next Generation Neural Interfaces Lab at the Imperial College London. From 2012 to 2014, he worked as an electronic engineer in Shanghai Research Institute, China Coal Technology and Engineering group.

### PUBLICATIONS

P Feng, P Yeon, M Ghovanloo, T G Constandinou, "Millimeter-scale integrated and wirewound coils for powering implantable neural microsystems," *Proc. IEEE Biomedical Circuits and Systems (BioCAS) Conference*, pp. 488–491, 2017.

K M Szostak, F Mazza, M Maslik, L B Leene, P Feng, T G Constandinou, "Microwire-CMOS integration of mm-scale neural probes for chronic local field potential recording," *Proc. IEEE Biomedical Circuits and Systems (BioCAS) Conference*, pp. 492–495, 2017.

mm-sized on-chip coils with NGNI logo for wireless power transfer and data communication

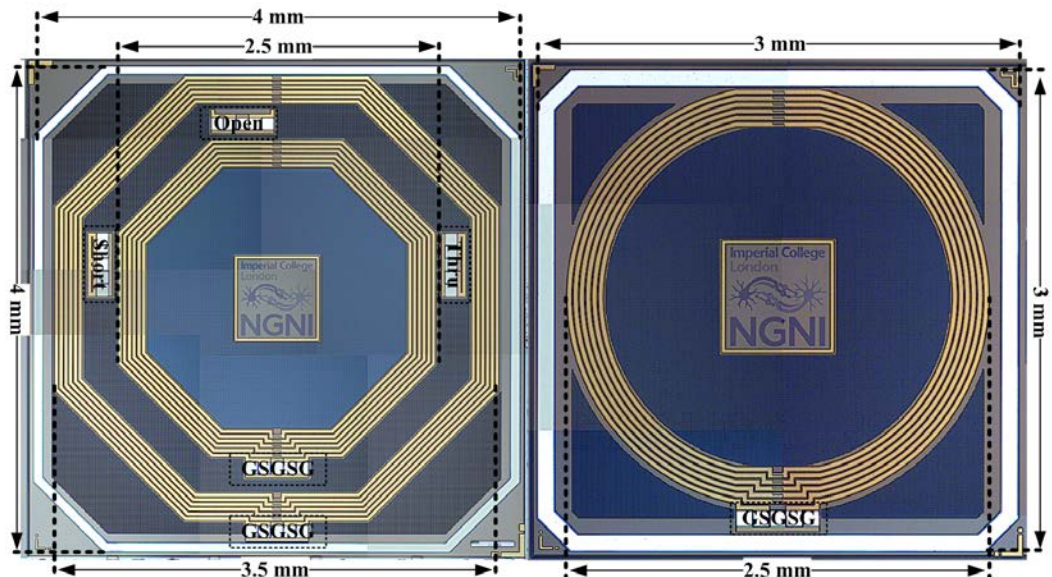



## Dorian Haci

### Research focus

Intrabody Power and Data Communication Systems for Active Multi-Module Neural Implants

### Supervisors

Dr Timothy Constandinou and Dr Sara Ghoreishizadeh

### Funding

Wellcome Trust/EPSRC (CANDO project)

### MOTIVATION

Debilitating neurological diseases, such as Parkinson's and Epilepsy, affect an increasing number of people and have a devastating effect on their quality of life. Novel treatments, based on neural interfaces, have shown to be an alternative solution to drugs, in many cases even more effective. Such brain-machine interfaces (BMI) exploit the electrical behaviour of the nerve cells by both monitoring the neural activity and, when needed, stimulating the nervous system to alleviate the symptoms. Within the CANDO project, an implantable medical device (IMD) is being developed with the requirement for multiple modules to reliably interact with each other. Such requirement poses several challenges, mainly related to power transfer and data exchange between the implanted modules. My research is thus focused on overcoming these challenges by defining a suitable communication protocol and implementing a reliable communication interface intended ultimately for a first-in-man trial.

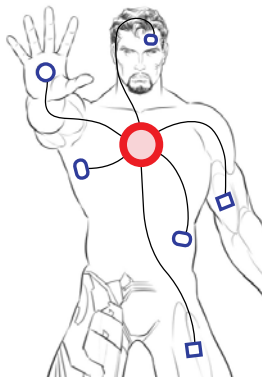

Concept of wired intrabody multi-module system

### OBJECTIVES

- To develop an interface that allows neural implants to efficiently connect between each other in an intrabody environment and perform reliable bidirectional data communication and power transfer.
- To evaluate the reliability of these implantable devices and patients' safety, within a human-body-like environment and multiple power domains.
- To investigate addressing techniques and algorithms to guarantee univocal accessing and avoid data collision in multi-module neural implants.

### RECENT ACHIEVEMENT

Results from the testing of a 4-wire interfacing systems for connecting multiple neural probes, designed in collaboration with Dr Liu and Dr Ghoreishizadeh, have been reported in two research papers (IEEE LASCAS'17 Conference and IEEE TCAS-I Journal). Moreover, the design of an instrumentation platforms to emulate the biological tissues was presented at the IEEE ISCAS'17 Conference in Baltimore. A novel method for adaptive power regulation and data delivery for multi-module implants has been proposed and a successful implementation (designed by MSc student Mr Mifsud) was presented at IEEE BioCAS'17 Conference in Turin.

### BIOGRAPHY

In 2012, Dorian received his BSc in Electronic Engineering at the Polytechnic University of Turin, Italy. He continued his studies with an MSc in electronic engineering, specialising in Communication Systems. He was awarded a scholarship for developing the MSc thesis project at Imperial College London, where he designed and implemented an innovative thermally controlled system for bio-applications using low cost PCB technology. Dorian received his MSc in Turin in December 2014 and joined the Next Generation Neural Interfaces (NGNI) group at the Centre for Bio-Inspired Technology as a Research Assistant in June 2015. Currently, he is also pursuing the PhD degree within the EEE Department.

### PUBLICATIONS

D Haci, Y Liu, T G Constandinou, "32-Channel ultra-low-noise arbitrary signal generation platform for biopotential emulation," *Proc. IEEE International Symposium on Circuits and Systems (ISCAS)*, pp. 698–701, 2017.

S S Ghoreishizadeh, D Haci, Y Liu, N Donaldson, T G Constandinou, "Four-Wire Interface ASIC for a Multi-Implant Link", *IEEE Transactions on Circuits and Systems I: Regular Papers*, vol. PP, no. 99, pp. 1–12, 2017.

A Mifsud, D Haci, S S Ghoreishizadeh, Y Liu, T G Constandinou, "Adaptive Power Regulation and Data Delivery for Multi-Module Implants", *Proc. IEEE Biomedical Circuits and Systems Conference (BioCAS)*, pp. 584–587, 2017.

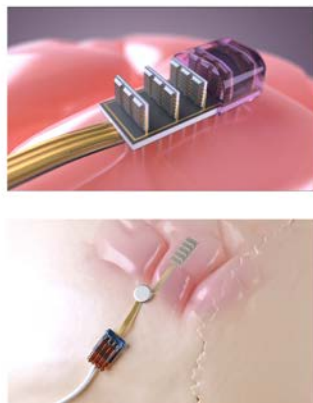

CANDO implantable system with multi-optrode neural interface



## Bernard Hernandez

### Research focus

Enhanced, Personalized and Integrated Care for Infection Management at Point of Care (EPIC IMPOC)

### Supervisor

Dr Pantelis Georgiou

### Funding

NiHR i4i

In hospitals, infections are one of the leading causes of patient admission and emergency visits and in the last years, there has been an increase in the number of microorganisms that have developed resistance against previously effective antimicrobials. This phenomenon, known as Antimicrobial Resistance (AMR), is a leading patient health and safety issue, with estimates that it will be responsible for more than 10 million deaths by 2050.

A vast amount of data is being collected by hospitals every day containing valuable AMR-related information. Therefore, there is an opportunity to develop an advanced decision support system that uses such large amount of data by applying machine learning algorithms to provide personalized, accurate and effective diagnostics at point of care.

### OBJECTIVES

- Improve consistency of collecting vital signs, support interpersonal communication through POC and facilitate interactions between clinicians, infection specialists and patients.
- Provide hospital-specific AMR-related statistics to revamp education/awareness among clinical staff to improve their prescription practices.
- Develop a hybrid approach which combines an experience-based methodology for problem solving with probabilistic inference to customise medical decisions to the individual patient.

### RECENT ACHIEVEMENT

To improve antibiotic prescribing and reduce patients' unnecessary exposure to antibiotics in hospitals, new mechanisms for supporting clinicians' decision making

are urgently required. Using exclusively six routinely collected biochemical markers enough information was available on a daily basis to perform infection inference with high degree of confidence (AUCROC>0.8) even in the presence of incomplete and imbalanced data using support vector machines. With further integration in a decision support system, this work holds promise of alleviating inadequate prescription practices to enhance infection management and contribute to halting the progression of AMR.

### BIOGRAPHY

Bernard Hernandez is research assistant and PhD candidate at Imperial College London. His PhD topic is to design a Decision Support System that provides personalized, accurate and effective diagnostics at point of care to reduce Antimicrobial Resistance. He received his B.S in Telecommunications and Computer Science from the University Rey Juan Carlos (URJC) in Madrid and his M.Sc. in Machine Learning from the Royal Institute of Technology (KTH) in Stockholm.

### PUBLICATIONS

Hernandez, Herrero, Rawson, More, Charani, Holmes and Georgiou. Data-driven Web-based Intelligent Decision Support System for Infection Management at Point-of-Care: Case-Based Reasoning Benefits and Limitations, Talk at the 10<sup>th</sup> International Conference on Health Informatics 2017, 21–23 Feb, Porto, Portugal  
 Hernandez, Herrero, Moore, Charani, Holmes and Georgiou. Point-of-Care Decision Support System for Antimicrobial Prescribing in the Intensive Care Unit. Poster session presented at: Imperial College London. *EMBRACE conference in Antimicrobial Resistance 2016*, Mar 9, London UK.

Left: ROC curves for the selected SVM classifier on different degrees of missing inputs (F4 indicates that four inputs are available)

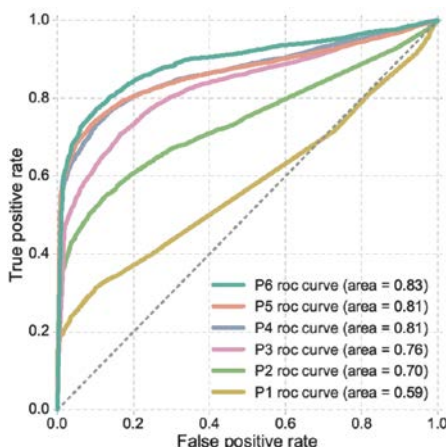

Right: PR curves for the selected SVM classifiers on different degrees of imbalanced categories (R60 indicates that 60% of the observations are culture-negative)

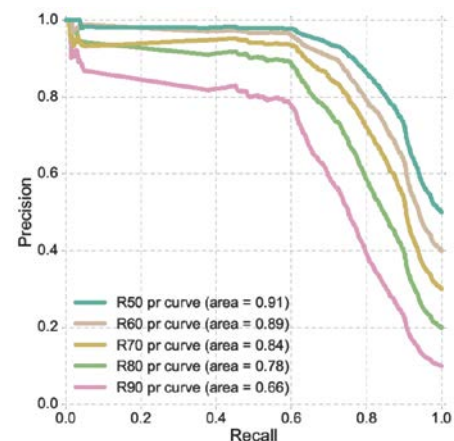





## Bryan Hsieh

### Research focus

Microdevices To Investigate Sleep and Temperature Regulation In Mice

### Supervisors

Prof. Nick Franks, Dr. Timothy Constandinou, Prof. Bill Wisden

### Funding

EPSRC Centre for Doctoral Training in Neurotechnology

### MOTIVATION

Sleep is one of the most important but also least understood biological processes. Short term sleep deprivation can cause lowered cognitive performance and alertness. During sleep the body undergoes various of physiological processes and one of them is the change in body core temperature. Although sleep is a natural process, some sedatives can achieve similar physiological affects which leads to the question whether they act on the same neural pathway.

To facilitate this study, there calls for a need of a compact (<15mm x 15mm), lightweight (<2g) neural-logging device that is also capable of recording both EEG signals and body temperature.

### OBJECTIVES

- To develop a compact, low energy EEG device that can record up to two days of data.
- To implement a BLE wireless link for real time data verification.
- To verify the performance of the device against devices already existing on the market.

### RECENT ACHIEVEMENT

During my MRes project, I have completed the first version of the device, measuring 6cm x 5cm in size, with 4 channels with an on-board SD card for storage. The device has undergone preliminary *in-vivo* validation and is currently being revised towards a more compact footprint and lower power consumption.

### BIOGRAPHY

Bryan Hsieh received the MEng degree in Biomedical Engineering (EEE stream) from Imperial College London in 2016. During his master thesis, he worked under Prof. Emmanuel Drakakis developing hardware for ultrasound imaging. Specifically, he designed a low

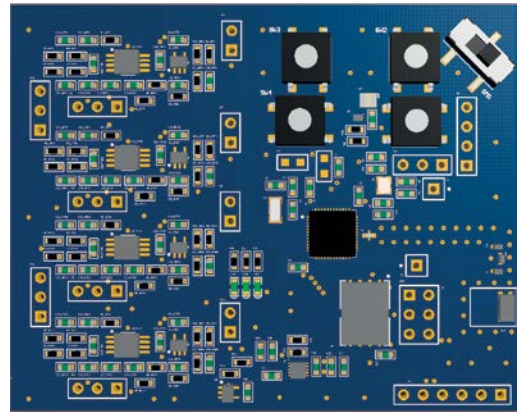

First working prototype based on a two stage amplifier (instrumentation amplifier then Sallen-Key Low Pass) and Nordic NRF528332 micro-controller

noise front-end PGA for an ultrasound imaging system with synthetic aperture, in addition to a verilog (FPGA) implementation of a beamforming algorithm. In October 2016, he joined the NGNI lab through the EPSRC CDT in Neurotechnology.

### KEY REFERENCES

- M Thomas, "Neural basis of alertness and cognitive performance impairments during sleepiness II. Effects of 48 and 72 h of sleep deprivation on waking human regional brain activity", *Thalamus & Related Systems*, vol. 2, no. 4, 2003.
- Z Zhang, V Ferretti, I G üntan, A Moro, E A Steinberg, Z Ye, N P Franks, "Neuronal ensembles sufficient for recovery sleep and the sedative actions of  $\alpha 2$  adrenergic agonists", *Nature Neuroscience*, vol. 18, no. 4, pp. 553–561, 2015.
- L Vyssotski, "Miniature Neurologgers for Flying Pigeons: Multichannel EEG and Action and Field Potentials in Combination With GPS Recording", *Journal of Neurophysiology*, vol. 95, no. 2, pp. 1263–1273, 2005.

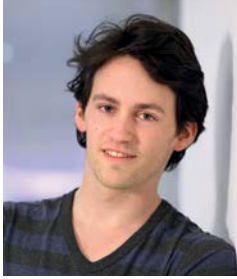

## Timo Lauteslager

### Research focus

Pulsed ultra-wideband radar-on-a-chip for medical imaging

### Supervisor

Dr. Timothy Constandinou

### Funding

EPSRC DTA

### MOTIVATION

Microwave techniques are of interest for medical imaging due to the harmless, non-ionizing radiation and tissue penetrating abilities. The recent development of low-cost and low-power radar-on-a-chip systems would allow for a portable imaging system that is particularly suitable for imaging moving structures, such as the blood vessels in the human body.

In the current project we collaborate with University of Oslo to investigate how we can use impulse-radio ultra-wideband (IR-UWB) radar for medical imaging. An array of radar modules in a circular imaging rig is used to measure variations in blood volume, both in limbs and in the head. Besides imaging of the cardiovascular system, this novel imaging technique could be used both for stroke imaging and for measuring brain activity.

### OBJECTIVES

- Testing imaging rig on phantoms: detecting a volume of blood in a brain-mimicking structure
- Imaging blood vessel movement in human limbs using multiple synchronized radar modules
- Optimizing beamforming algorithm for a circular imaging rig and pulsating targets

### RECENT ACHIEVEMENT

Through a 3-month internship at UWB radar producer Novelda AS, expertise was gained in digital beamforming techniques, particularly for co-located multistatic radar imaging scenarios. Imaging phantoms have been created that mimic a brain-like

structure with small blood clots of varying sizes.

Improvements have been made on the measurement setup and an 8-module imaging rig was developed. A beamforming algorithm was developed to produce 2D images from the first recordings that were made using the multi-module imaging setup.

### BIOGRAPHY

Timo Lauteslager followed his undergraduate in Biomedical Engineering at the University of Twente, The Netherlands, where he received his BSc degree in 2012. Subsequently he was awarded with a 2 year Erasmus Mundus scholarship from the European Committee. This scholarship allowed him to follow a joint degree master program in Biomedical Engineering, at Czech Technical University and Trinity College Dublin. He specialized in biosignal processing and neural engineering. In 2014 he received his MSc with distinction from both universities. Timo has joined the Neural Interfaces group at the Centre for Bio-inspired Technology as a PhD candidate in January 2015.

### RECENT PUBLICATIONS

T Lauteslager, N Nicolaou, T S Lande, T G Constandinou, "Functional neuroimaging using UWB impulse radar: A feasibility study", *Proc. IEEE Biomedical Circuits and Systems (BioCAS) Conference*, pp. 1–4, 2015.

T Lauteslager, M Tømmer, K G Kjelgård, T S Lande, T G Constandinou, "Heart Rate Detection Using UWB Radar," *Proc. IEEE Biomedical Circuits and Systems (BioCAS) Conference*, pp. 119–122, 2016.

*Transmissive radar measurements on the human head using a single radar module; to detect intracranial heart rate*

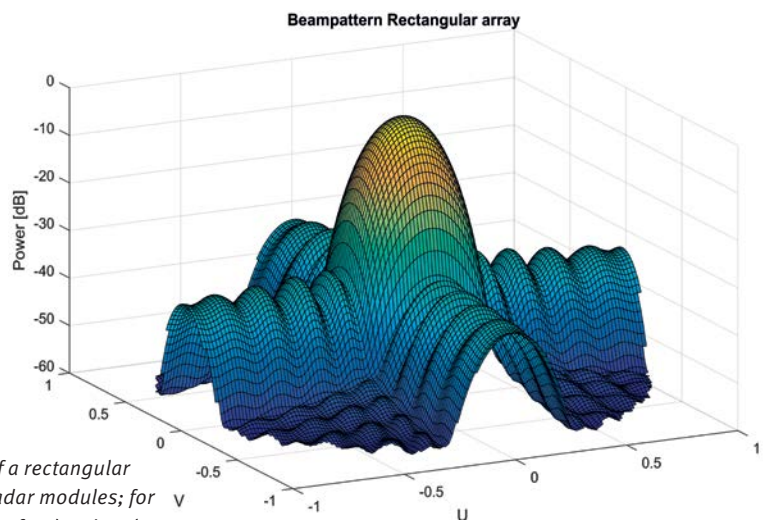
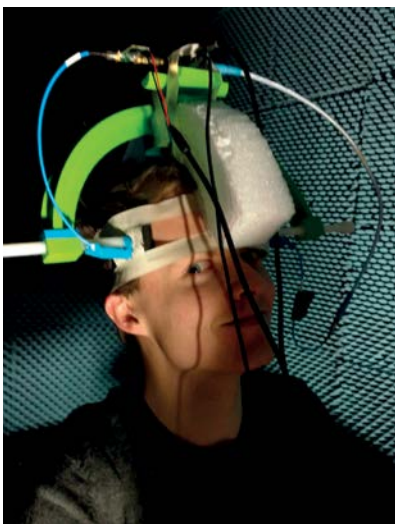

*Beampattern of a rectangular array of UWB radar modules; for spatial filtering of radar signals*



## Xiaoran Liu

### Research focus

A knowledge based expert system for consumer genetics

### Supervisor

Prof Chris Toumazou

### MOTIVATION :

It is believed that molecules within the human metabolism is controlled by the language of genes, which could be controlled and alternated to help people optimise health and prevent, even reverse some complex diseases like cardiovascular disease or type 2 diabetes eventually. To those associations, Single Nucleotide Polymorphisms (SNPs) plays a significant role in genetic variations. The introduction of Machine Learning algorithm to deal with highly complex SNPs correlation enables deeper understanding at the metabolic pathway, aiming to improve Nutrigenomics. The goal of my research is to provide more causality results from experiments among specific nutrition, specific disease and SNPs.

Framework of Tag SNPs with a Pre-knowledge system

### OBJECTIVES

- Research over whole existing informative SNPs selection algorithms
- SNPs Selection Algorithm
- Data extraction of online resources to be implemented into the expert system

### RECENT ACHIEVEMENT

The achievement includes data collection and pre-processing, which includes web data extraction and conversion of different open sources and different format. Also, research over existing informative SNPs selection algorithms with high accuracy of SNPs reconstruction. Comparisons among different featured SNPs selection algorithms based on different approaches, which includes tag SNP selection and SNPs prediction.

### BIOGRAPHY

I am currently a PhD student under supervision of Prof. Christofer Toumazou and co-supervised by Prof. Yike Guo. My background is from computer science, especially machine learning. My current research is machine learning algorithm for genetics and association between nutrition and SNPs.

### PUBLICATIONS AND KEY REFERENCES

- C Toumazou, L M Shepherd, S C Reed, G I Chen, A Patel, D M Garner, Chan-Ju A Wang, C Ou, K Amin-Desai, Panteleimon Athanasiou, H Bai, I M Q Brizido, B Caldwell, D Coomber-Alford, P Georgiou, K S Jordan, J C Joyce, M La Mura, D Morley, S Sathyavrudhan, S Temelso, R E Thomas & L Zhang 2013. Simultaneous DNA Amplification and Detection using a pH-sensing Semiconductor System. *Nature Methods American* 2013.
- B Liao, X Li, W Zhu, and Z Cao, 2012. A Novel Method to Select Informative SNPs and Their Application in Genetic Association Studies. *IEEE CS, CI, and EMB Societies & the ACM* 2012.
- The International HapMap Consortium. "The International HapMap Project". *Nature* vol 426, pp. 789-796, 2003.

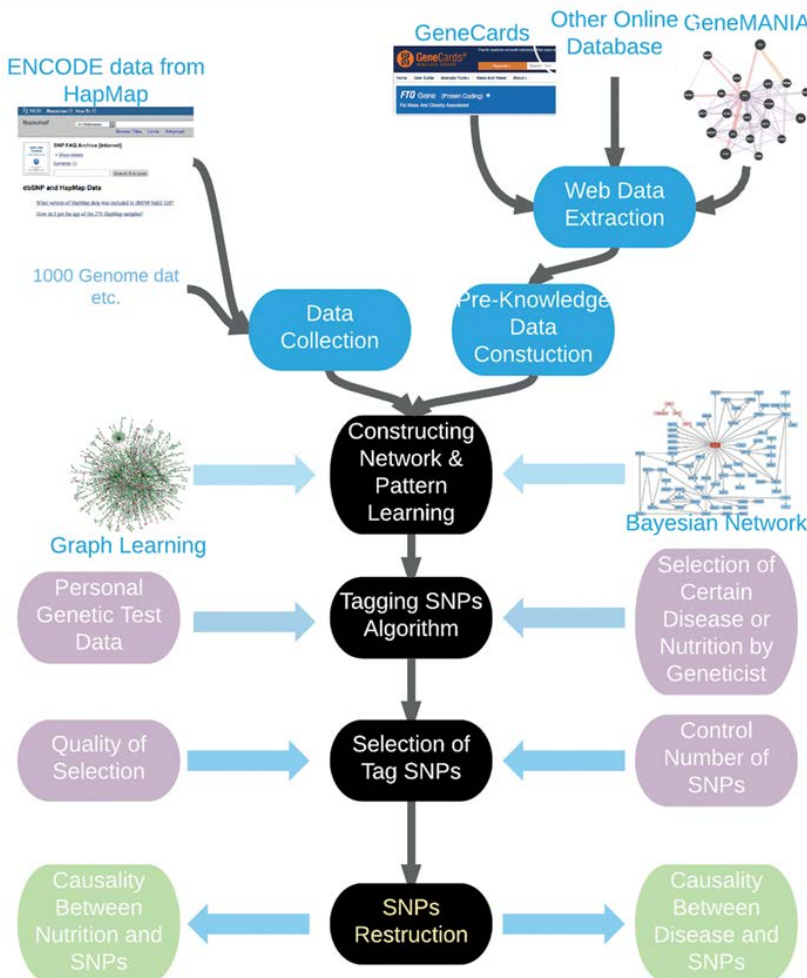



## Dora Ma

**Research focus**

Semiconductor design methodologies for epigenetic monitoring

**Supervisor**

Prof Chris Toumazou

**Funding**

EEE Departmental Scholarship

**MOTIVATION**

In recent years, global mortality has been dominated by non-communicable diseases. The rising incidence and prevalence of chronic diseases suggests that modern lifestyle is the main contributor to a person’s decline in health. Generally, the risk of death from chronic diseases can be attributed to the lack of early symptoms and cure.

Epigenetics is changes in gene expressions stimulated by environmental influences. Particularly, there is strong evidence demonstrating its role in the progression of chronic diseases, providing prospects for new biomarkers and therapeutics. Development of technology to accommodate fast detection at low costs is essential for integrating epigenetic monitoring into future healthcare.

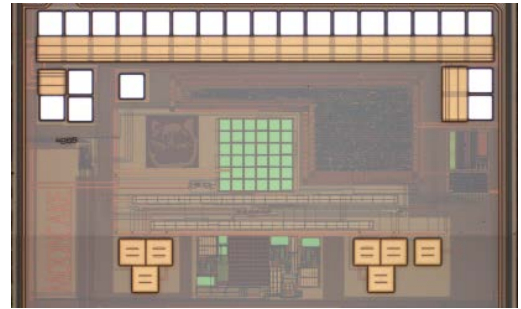

Micro-photograph of the latest fabricated microchip ‘Mooncake’

**OBJECTIVES**

- Apply CMOS design techniques to develop circuits for detecting various types of epigenetic modifications, namely DNA methylation and microRNA regulations.
- Design and implement sensing and processing circuits tailored to different DNA methylation analyses: Methylation-specific PCR and bisulfite sequencing.
- Development of back-end on-chip processing to enable fully portable microRNA quantification and reduce detection time for amplification reactions.

**BIOGRAPHY**

I am a fourth year PhD student. I graduated from Imperial College in 2013 with a MEng from the department of Electrical and Electronic Engineering. Having done my final year project on analogue signal processing for DNA sequencing with Professor Toumazou, I continued to pursue my PhD in a similar area.

**PUBLICATIONS**

D Ma, P Georgiou, and C Toumazou. “An ISFET-based switched current DNA integrator.” *Circuits and Systems (ISCAS), 2016 IEEE International Symposium on*. IEEE, 2016.

D Ma, P Georgiou, and C Toumazou. “A weak inversion ISFET current mirror for differential bio-sensing.”, *2016 IEEE Biomedical Circuits and Systems Conference (BioCAS)*. IEEE, 2016.

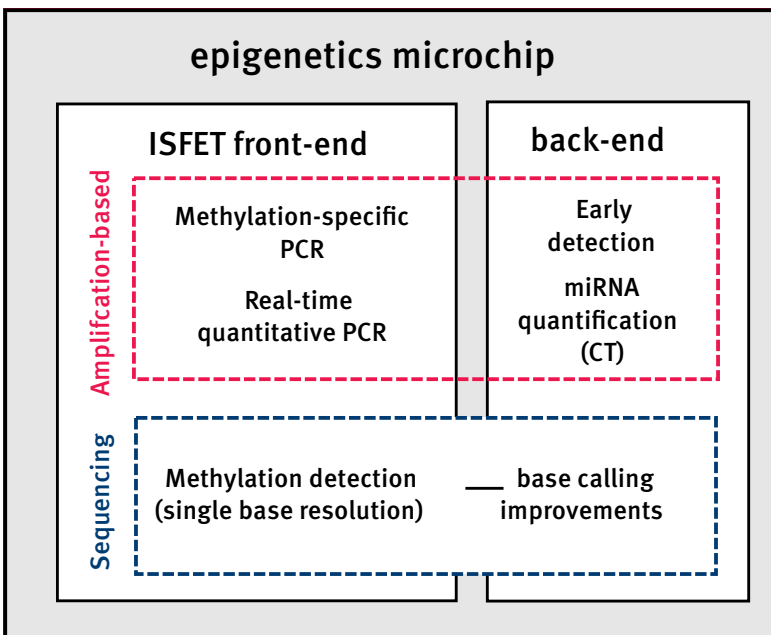



### Michal Maslik

#### Research focus

Microelectronics for next generation neural interfaces

#### Supervisor

Dr Timothy Constandinou

#### Funding

Imperial College President's PhD Scholarship

#### MOTIVATION

Neural implants allowing acquisition of signals inside a human brain have now been available for a relatively long time. Aided by sophisticated signal processing they can facilitate direct control of artificial limbs or computers and therefore greatly improve life quality of e.g. paraplegic or otherwise disabled patients.

Current implants however suffer from poor reliability and limited longevity which is often caused by their large size and necessity of wired connections passing through the patient's skull. This can be greatly improved by developing a new generation of implants that would be completely wireless and minimal in size.

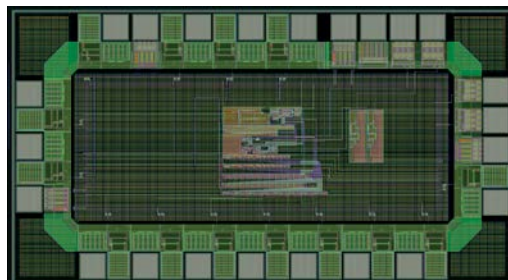
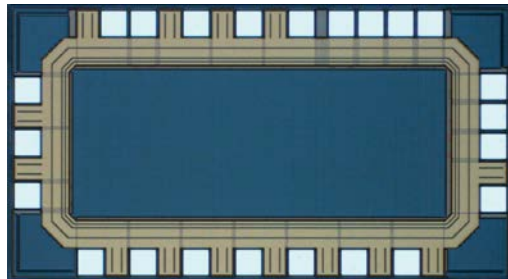

Microphotograph and exported layout of the designed CT-ADC Circuit

#### OBJECTIVES

- Investigate novel materials for use in recording electrodes.
- Develop microelectronic circuits to be used in next generation of wireless neural implants.
- Investigate novel compression methods for Local Field Potentials, low-frequency neural signal contents.

#### RECENT ACHIEVEMENT

I have completed measurements of a novel Continuous-Time Analogue-to-Digital Converter (CT-ADC) topology aimed for use in neural implants that I designed during my MEng studies at Imperial College. The results have been presented at ISCAS 2017 Conference in Baltimore and the paper was subsequently invited to be extended for a special issue of Transactions on Biomedical Circuits and Systems (TBioCAS) journal.

In addition I have run experiments identifying niobium as a potential novel material for electrodes aimed at recordings of low-frequency neural signals. Those findings have been included alongside work of other colleagues in a publication presented at BioCAS 2017 Conference in Turin.

#### BIOGRAPHY

Michal Maslik received his MEng (Hons) degree in Electrical & Electronic Engineering from Imperial College London in 2016. He joined the Next Generation Neural Interfaces research group in October 2016 as a PhD student collaborating on the ENGINI project. During his PhD studies his main focus is on research of recording microelectrode materials and development of novel microelectronic circuits allowing acquisition and processing of neural signals. In addition, he is also interested in novel methods of Local Field Potential compression and feature extraction.

#### PUBLICATIONS

M Maslik, Y Liu, T S B Lande, T G Constandinou, "A charge-based ultra-low power continuous-time ADC for data driven neural spike processing", *Proc. IEEE International Symposium on Circuits and Systems (ISCAS)*, 2017

K M Szostak, F Mazza, M Maslik, L B Leene, P Feng, T G Constandinou, "Microwire-CMOS Integration of mm-Scale Neural Probes for Chronic Local Field Potential Recording", *Proc. IEEE Biomedical Circuits and Systems (BioCAS) Conference*, 2017.



### Federico Mazza

**Research focus**

Integrated Devices for Reliability and Long-Term Stability of Neural Implants

**Supervisor**

Dr Timothy Constandinou

**Funding**

EPSRC DTA and ENGINI project

**MOTIVATION**

Neural prostheses have demonstrated to be successful in treating multiple neurological conditions, ranging from Parkinson’s disease to hearing impairments. However, the technology has yet to show its full potential, and extend to areas such as the control of artificial prosthetic limbs.

Despite the advancements attained by various research initiatives in the characterization of brain signals, microfabrication technologies, and real-time signal processing methods, the problem of chronic stability of implants is restraining clinical applications.

Resolving issues such as the reliability of the electrode/tissue interface, and the reliability of packaging/encapsulation are critical towards implementing future systems.

**RECENT ACHIEVEMENT**

The design and fabrication of a passive mm-sized microwire based neural micro-implant has been carried out. The device accounts for the future integration of active CMOS circuits and antenna for wireless power and data transfer.

The fabrication process was carried out inside our facilities, and was based on direct laser writing photolithography, which allows for faster prototyping time compared to standard mask-based techniques.

**BIOGRAPHY**

Federico Mazza obtained his BSc in Electronic Engineering from the Polytechnic University of Turin, Italy in 2012. He next enrolled in the MSc course on Integrated Electronics and Optoelectronics. During the master he was selected for a double degree program between the Polytechnic University of Turin and the University of Illinois at Chicago, USA, where he worked on his master thesis project. He received his MSc from both universities in 2014. After having worked for one year in a company operating in the field of industrial robotics, Federico joined the Next Generation Neural Interfaces group, within Centre for Bio-Inspired Technology as a PhD student in January 2016.

**PUBLICATIONS**

K Szostak, F Mazza, M Maslik, P Feng, L Leene, TG Constandinou, “Microwire-CMOS Integration of mm-Scale Neural Probes for Chronic Local Field Potential Recording”, *IEEE Biomedical Circuits and Systems (BioCAS) Conference*, IEEE, 2017.

**KEY REFERENCES**

A C Patil, N V Thakor, “Implantable neurotechnologies: a review of micro-and nanoelectrodes for neural recording”, *Medical & biological engineering & computing*, vol. 54, no. 1, pp. 23–44, 2016.

C Eder, V Valente, N Donaldson, A Demosthenous, “A CMOS smart temperature and humidity sensor with combined readout”, *Sensors*, vol. 14, no. 9, pp. 17192–17211, 2014.

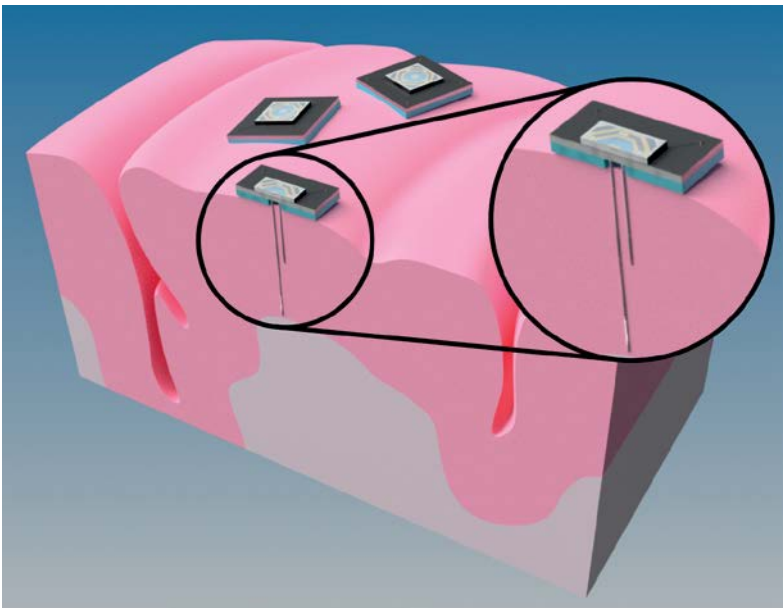

Rendering of the microwire-based ENGINI wireless neural probes

**OBJECTIVES**

- Study the reliability of a humidity sensing device for testing the encapsulation of implantable neural micro-packages and monitor leakages.
- Integrate such device into a floating mm-scale neural micro-implant for in vivo testing.
- Investigate different approaches for the microfabrication of highly-scalable feedthrough connections in neural implantable devices.



## Khalid Baig Mirza

### Research focus

Research & development of closed loop appetite monitoring systems for advanced obesity management

### Supervisor

Professor Chris Toumazou

### Funding

ERC Synergy (i2Move)

### MOTIVATION

WHO statistics indicates obesity as the second largest preventable cause of death after tobacco consumption and current estimates put the cost of obesity management at \$47 billion, \$6 billion of which is shared by NHS alone.

Gastric Bypass Surgery is expensive and accompanied by many complications. Therefore, it is necessary to explore suitable alternatives such as Vagus Nerve Stimulation (VNS) since the vagus nerve plays a major role in appetite regulation and food intake<sup>[2]</sup> and couple it with accurate markers of appetite to enhance effectiveness of the therapy.

### OBJECTIVES

- Identify *neurometabolic* biomarkers in vagus nerve signals, which are linked to appetite.
- Develop implantable neurotechnology to enable minimally invasive, closed-loop *therapeutic* obesity management using VNS in morbidly obese patients.
- Explore options for non-invasive monitoring of appetite through biomarkers leading towards a *preventive, personalised* approach to obesity management in mildly obese patients.

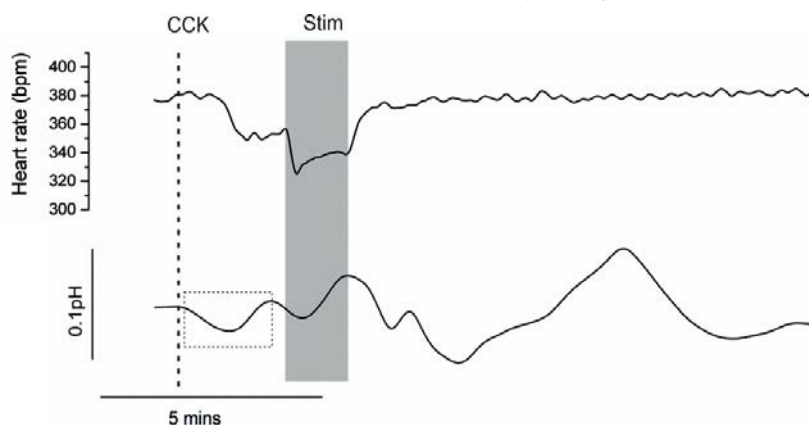

*Demonstration of the closed-loop capabilities of pHe monitoring using IrOx microelectrodes in anaesthetised rats. IrOx microelectrodes were inserted into the subdiaphragmatic vagus nerve (A) and 300pmol/kg CCK injected intravenously (B, dashed line). Custom made Matlab script implementing feature extraction techniques which monitored changes in pHe, detected the relative change caused by CCK (B, boxed area) and subsequently activates a stimulator implanted on the ipsilateral cervical vagus nerve (B, shaded area) to bring about a reduction in heart rate. Note that CCK also produces a reduction in heart rate. N=11 animals.*

### RECENT ACHIEVEMENT

Identified cholecystokinin(CCK) induced chemical changes in the gastric branch of vagus nerve.

Developed a novel platform to implement and optimize closed loop VNS modalities based on neurochemical and Compound Nerve Action Potential signals.

### BIOGRAPHY

I completed my MSc in Analogue and Digital IC Design from Dept. of Electrical and Electronic Engineering, Imperial College London and started working as an Electronics Engineer for Ingenia Technology, in a product design team to implement a novel authentication technology called Laser Surface Authentication (LSA). After 2.5 years at Ingenia, I returned to work and pursue a PhD at the Institute of Biomedical Engineering, Imperial College London. Currently, I am working under the ERC funded I2MOVE Synergy project to develop an intelligent, implantable vagus nerve stimulator.

### PUBLICATIONS AND KEY REFERENCES

S C Cork, A Eftekhar, K B Mirza, J Gardiner, S Bloom, and C Toumazou, "Extracellular pH monitoring for use in closed-loop vagus nerve stimulation," *J. Neural Eng.* 2017 (In press).

K Mirza, C Zuliani, B Hou, F S Ng, N S Peters, and C Toumazou, "Injection Moulded Microneedle Sensor for Real-Time Wireless pH Monitoring," in *Engineering in Medicine and Biology Conference*, 2017.

K B Mirza, S Luan, A Eftekhar, and T Constandinou (2012, May). "Towards a fully-integrated solution for capacitor-based neural stimulation" in *Circuits and Systems (ISCAS), 2012 IEEE International Symposium on* (pp. 2243–2246). IEEE.

K Behrns, "Bariatric Surgery and Long-term Cardiovascular Events," *Yearbook of Surgery*, vol. 2012, pp. 236{238, 2012}.

H R Berthoud, "The vagus nerve, food intake and obesity," *Regulatory Peptides*, vol. 149 pp. 15{25, 2008}.



## Nicholas Miscourides

### Research focus

Chemical Sensing Platforms based on ISFET Current-Mode Arrays

### Supervisor

Dr Pantelis Georgiou

### Funding

EPSRC Centre for Doctoral Training in High Performance Embedded and Distributed Systems (HiPEDS)

### MOTIVATION

Semiconductor-based ion-sensitive sensors (ISFETs) are becoming increasingly popular as the preferred method for sensing ion concentrations due to their compatibility with CMOS processes which enables them to take advantage of the well-established semiconductor ecosystem. Monolithic integration ensures that ISFET sensors can be miniaturized, mass-fabricated and low-cost with the ability to add signal/data processing functionality on the same IC as the sensor. As a result, ISFET-based chemical sensing platforms can serve as the host for chemical reactions with electronic readout and control. However, as this is relatively a new technology, significant time and effort is required to ensure the robustness, reliability and longevity of the sensor. In this context, my research focuses on addressing some of the challenges involved with ISFETs as the sensing front-end of larger chemical sensing platform.

### OBJECTIVES

- Design circuit architectures for large-scale sensing arrays which exploit current-mode operation to achieve sensor linearity and high frame rate.
- Develop a framework that minimizes human intervention during the calibration-monitoring-readout pipeline of the sensor arrays. This is based on a sensor self-interrogation technique to assess its state.
- Investigate novel applications which benefit from fast ionic monitoring as opposed to DNA sequencing applications which are relatively slow compared to typical electronic applications.

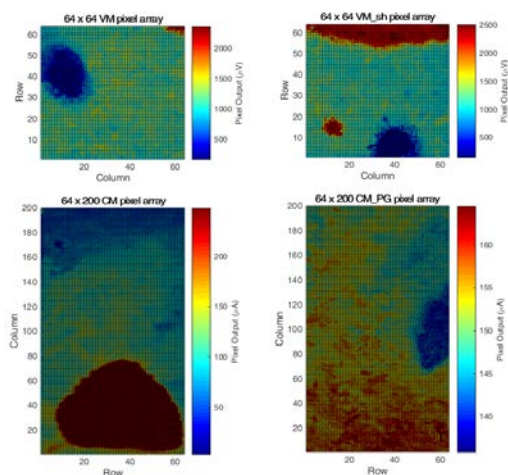

Chip microphotograph and array output from 34K sensors with surface phenomena showing in real-time on a MATLAB-based GUI.

### RECENT ACHIEVEMENT

Completed the generation 2 of our latest IC for real-time monitoring of chemical reactions. The latest design comprises 4 ISFET arrays for ionic imaging, a total of 34K sensors and a common temperature sensor. This IC will serve as the core of the chemical sensing platform with the possibility of both voltage and current mode of operation, fast array frame readout and automatic compensation using the programmable gate approach. Additionally, a PC-based interface has been designed which takes into account first-order sensor non-idealities such as drift while performing real-time calibration. On a different note, a short video describing this research has been filmed and can be found on the HiPEDS website.

### BIOGRAPHY

Nicholas received the M.Eng. degree (Hons) in Electrical and Electronic Engineering in July 2014 and the M.Res. degree (Distinction) in High-Performance Embedded and Distributed Systems (HiPEDS) in September 2015 both from Imperial College London. During his studies, he was awarded the Sir Bruce White Prize for the best MEng thesis of his year. Currently he is pursuing the Ph.D. degree at the Centre for Bio-Inspired Technology jointly with the HiPEDS Centre for Doctoral Training. Nicholas is a scholar of the A. G. Leventis Foundation.

### PUBLICATIONS AND KEY REFERENCES

N Miscourides, P Georgiou, "Linear Current-Mode ISFET Arrays," in *2016 IEEE International Symposium on Circuits and Systems (ISCAS)*, May 2016, pp. 2827–2830.

N Miscourides, P Georgiou, "A Linear Programmable-Gate ISFET Array Operating in Velocity Saturation," in *2016 IEEE Biomedical Circuits and Systems Conference (BioCAS)*, October 2016.







## Nicolas Moser

### Research focus

Integrated sensing platforms for ion imaging and point-of-care diagnostics for infectious diseases

### Supervisor

Dr Pantelis Georgiou

### Funding

EPSRC Centre for Doctoral Training in High Performance Embedded and Distributed Systems (HiPEDS)

### FUNDING

Motivation: ISFETs have been used extensively as chemical sensors for their integration with commercial CMOS technology and their inherent sensitivity to pH. As such, they can be used to design Point-of-Care (PoC) devices for the diagnosis of DNA- or RNA-based diseases. Not only can this technology be used to diagnose infectious pathogens fast in UK hospitals, it also allows to raise the alarm for outbreaks of infectious diseases including dengue, Zika and Chikungunya in remote locations.

The device also allows for ion monitoring in the blood, which could prevent athletes or soldiers to collapse due to low blood sodium levels.

### OBJECTIVES

- Develop a Point-of-Care ion detection platform using CMOS technology.
- Compensate for sensor non-idealities, such as trapped charge or drift, at device level.
- Investigate applications for such a device in the fields of early diagnostics and patient monitoring, including on-chip DNA amplification and detection.

### RECENT ACHIEVEMENT

Following the microchips fabricated in the past few years (BATMAN and TITANICKS), Nicolas has been working with his team at the boundaries of electronics and biology, achieving on-chip isothermal DNA amplification, validated with the dengue virus. This work was presented at ISCAS17 in Baltimore in the form of two live demonstrations, one of which was runner-up for the best live demo.

Nicolas has recently fabricated an updated version of the TITANICKS chips in anticipation for the upcoming 8000 sensor chip which will be mass produced for the wide range of applications considered.

### BIOGRAPHY

Nicolas obtained his Bachelor's Degree in Electronics and Chemical Engineering at the Université Catholique de Louvain (UCL) in Belgium in 2013. He then graduated in 2014 with an MSc Degree at Imperial College London in Analogue & Digital Integrated Circuit Design, where he received the Award for the best MSc project with significant original contribution to the topic area and the MSc Outstanding Achievement Prize. He is now in the third year of a PhD programme part of the Centre for Doctoral Training in High Performance Embedded and Integrated Systems (HiPEDS).

### PUBLICATIONS AND KEY REFERENCES

N Moser, J Rodriguez-Manzano, L-S Yu, M Kalofonou, S de Mateo, X Li, T S Lande, C Toumazou and P Georgiou, "Live Demonstration: A CMOS-Based ISFET Array for Rapid Diagnosis of the Zika Virus," *2017 IEEE International Symposium on Circuits and Systems (ISCAS)*, Baltimore, 2017.

N Moser, T S Lande, C Toumazou and P Georgiou, "ISFETs in CMOS and Emergent Trends in Instrumentation: A Review," in *IEEE Sensors Journal*, vol. 16, no. 17, pp. 6496–6514, Sept.1, 2016.

Y Hu, N Moser and P Georgiou, "A 32x32 ISFET Chemical Sensing Array With Integrated Trapped Charge and Gain Compensation," in *IEEE Sensors Journal*, vol. 17, no. 16, pp. 5276–5284, Aug.15, 2017.

N Moser, T S Lande and P Georgiou, "A robust ISFET array with in-pixel quantisation and automatic offset calibration," *2016 IEEE Biomedical Circuits and Systems Conference (BioCAS)*, Shanghai, 2016, pp. 50–53.

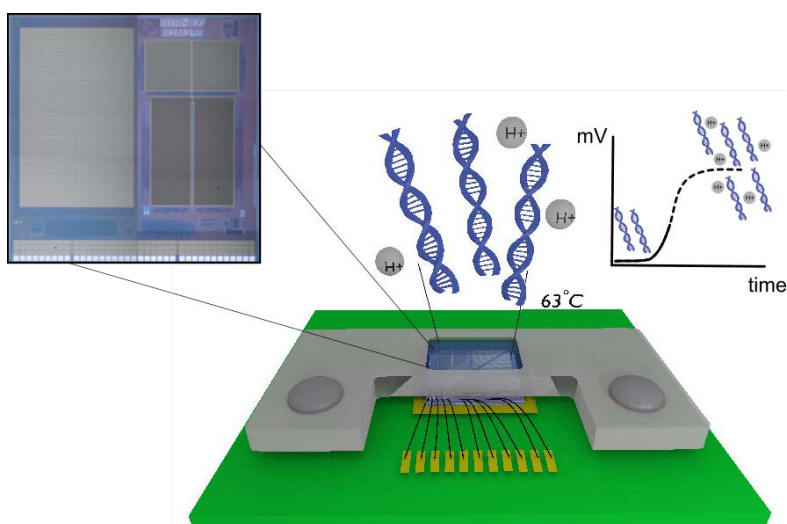

The TITANICKS chip integrates more than 4000 chemical sensors. It is able to amplify and detect DNA to diagnose infectious diseases



## Christoforos Panteli

### Research focus

Graphene devices for breath and blood analysis

### Supervisors

Dr Kristel Fobelets and Dr Pantelis Georgiou

### Funding

EPSRC DTA

### MOTIVATION

The future of medicine is to perform diagnosis and if possible treatment with the minimum invasiveness in the body. Hence, breath, urine and blood analysis are diagnosis methods which have increased popularity over the last years. Nanotechnology can assist the development of sensors and systems to perform these analyses.

Graphene is a relatively new material with extraordinary properties such as huge electrical and thermal conductivity and mechanical robustness. Utilising this material for breath and blood analyses can boost the performance of already existing sensors or systems and begin a new era of non-invasiveness, quick, reliable and cheap medical diagnosis.

### OBJECTIVES

- Analyse gas and liquid adsorption on graphene
- Improve the performance of gas sensors using graphene
- Improve the performance of CMOS ISFETs utilising reactive ion etching post-processing and graphene

### RECENT ACHIEVEMENTS

- Universal, high yield transfer process of multilayer graphene sheets over centimeters squared area.
- Suspended multilayer graphene on Silicon Nanowire arrays.
- Improved sensitivity of graphene ammonia gas sensors (Fig. 1).
- Improved CMOS ISFET performance by reactive ion etching post-processing (Fig. 2).

### BIOGRAPHY

Christoforos Panteli comes from Cyprus and has graduated with MEng degree first class honors from the department of Electrical and Electronic Engineering in Imperial College London in 2015. He started his PhD in the same department under the supervision of Dr Kristel Fobelets and Dr Pantelis Georgiou in the research groups Optical and Semiconductor Devices and Centre of Bio-inspired technology. His research interests are applied physics for biomedical applications.

### PUBLICATIONS

- K Fobelets, C Panteli, O Sydoruk, C B Li, "Ammonia Sensing using Arrays of Silicon Nanowires and Graphene", *Journal of Semiconductors*, 2017
- C Panteli, D Liu, O Sydoruk and K Fobelets, "Through-Graphene Etching of Porous Si by Electroless Metal Assisted Chemical Etching", *Micro and Nano Engineering Conference, Vienna Austria*, 19–23 September, 2016
- C Panteli, O Sydoruk and K Fobelets, "Graphene Suspended on Silicon Nanowire Arrays for Enhanced Gas Sensing", *231st Electro-Chemical Society Meeting, New Orleans US*, 28 May – 1 June, 2017
- C Panteli, N Moser, P Georgiou and K Fobelets, "Optimising the Performance of Commercial ISFET sensors using Reactive Ion Etching", *Micro and Nano Engineering Conference, Braga Portugal*, 18–23 September, 2017
- N Moser, C Panteli, D Ma, C Toumazou, K Fobelets and P. Georgiou, "Improving the pH Sensitivity of ISFET Arrays with Reactive Ion Etching", *BioCAS Turin Italy*, 19–21 October, 2017

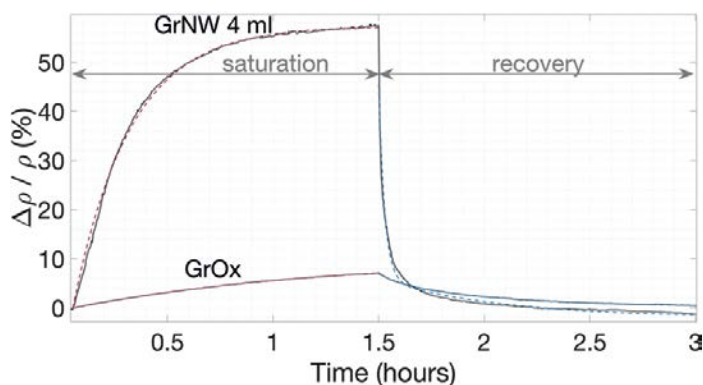

Percentage increase in graphene's resistivity on SiO<sub>2</sub> (GrOx) and on Nanowire arrays (GrNW) when exposed to ammonia vapour

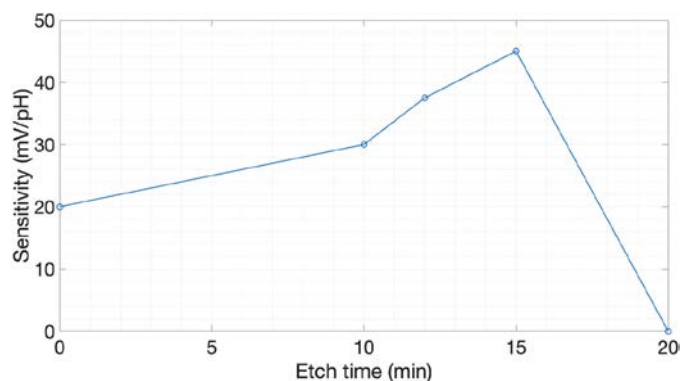

Increase in pH sensitivity of CMOS ISFETs for different etch times in the ion plasma.



## Adrien Rapeaux

### Research focus

Systems and Algorithms for Highly Selective Neural Interfacing

### Supervisor

Dr Timothy Constandinou

### Funding

EPSRC Centre for Doctoral Training in High Performance Embedded and Distributed Systems (HiPEDS)

### MOTIVATION

Neural stimulation implants offer powerful therapeutic tools today targeting an increasing number of pathologies. Deep brain stimulation to alleviate Parkinson's disease, cochlear stimulation to provide hearing to the deaf, and vagus nerve stimulation to combat obesity are but a few examples of impressive clinical success.

The breadth of possible therapies is limited, however, by the low selectivity of FDA-approved implanted electrodes. While one approach to solve the problem is to increase selectivity by making implants more invasive, this approach is difficult due to how fragile nervous tissue reacts to invasive implants. Another approach is to investigate how changing the stimulation algorithm can improve selectivity with existing technology, which is at the core of my work. A particular example is the use of high-frequency alternative current (HFAC) which combined together with conventional stimulation can yield more selective stimulation with existing electrodes.

### OBJECTIVES

- Establish a robust and reliable protocol to investigate high frequency alternative current block in conjunction with conventional stimulation
- Design an implantable ASIC for combined HFAC and conventional stimulation
- Demonstrate improved selectivity with existing commercial FDA-approved electrodes

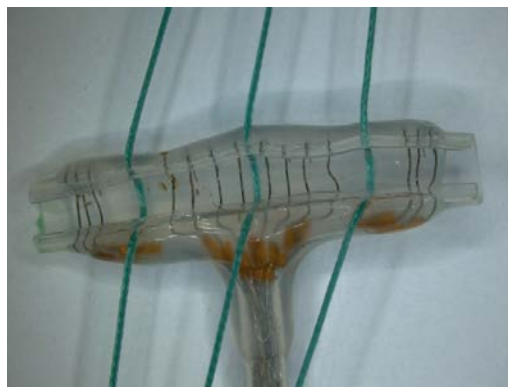

Custom cuff electrode for rat sciatic nerve

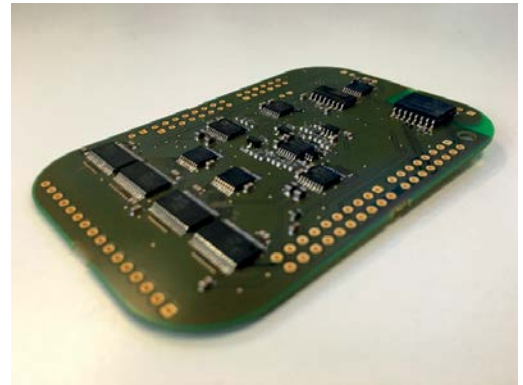

High frequency neural stimulator circuit board

### RECENT ACHIEVEMENT

Experiments on HFAC were carried out in Sprague-Dawley rats at Newcastle University as part of an ongoing collaboration, where a combination of HFAC and conventional stimulation was investigated. Initial results encourage additional study of HFAC to gain an understanding of its precise dynamics which aren't captured by modern computational models. The results of that study are pending submission for publication in a scientific journal.

### BIOGRAPHY

Adrien Rapeaux is currently pursuing doctoral studies in Imperial's High Performance Embedded and Distributed Systems (HiPEDS) Centre for Doctoral Training programme. He graduated from Phelma School of Engineering in Grenoble, France in 2014 with a Master in Electrical and Electronic Engineering. His research interests include neuroprosthetics, neuromodulation and peripheral nerve implants.

### RECENT PUBLICATIONS

I Williams, A Rapeaux, Y Liu, S Luan and T G Constandinou, "A 32-ch. bidirectional neural/EMG interface with on-chip spike detection for sensorimotor feedback," *Proc. IEEE Biomedical Circuits and Systems (BioCAS) Conference*, pp. 528–531, 2016.

A Rapeaux, K Nikolic, I Williams, A Eftekhar and T G Constandinou, "Fiber size-selective stimulation using action potential filtering for a peripheral nerve interface: A simulation study," *Proc. Annual International Conference of the IEEE Engineering in Medicine and Biology Society (EMBC)*, pp. 3411–3414, 2015.



## Francesca Troiani

### Research focus

Optical coherence tomography for detection of compound action potential

### Supervisors

Dr Timothy Constandinou and Dr Konstantin Nikolic

### Funding

EPSRC DTA

### MOTIVATION

At the current stage of research it is not possible to record neural activity without having to choose between a non-invasive setup and a good resolution. This creates the need for a new methodology that would act like a bridge between non-invasive (and low resolution) and invasive (and high resolution) techniques.

In the 60s neuroscientists have discovered changes in light scattered from a neuron during action potential and, since then, optical properties of neurons have been extensively studied. Thus the use of light, with its characteristic to travel through matter, seems to be the best chance to detect neural activity non-invasively.

### OBJECTIVES

- Measuring nerve activity non-invasively using optical techniques
- Creating an artificial model for the optical properties of the nerve
- Creating a theoretical model for the nerve and simulating optical detection of action potential

### RECENT ACHIEVEMENT

I developed a model for computation of A line scans in time domain optical coherence tomography (OCT). The model is composed of a first part computing the response of the two arms of the interferometer and a second – post processing – part that combines said responses to create the OCT signal.

In June 2017, I attended the European Conference on Biomedical Optics (ECBO) where I presented my work on “Optical coherence tomography for compound

action potential detection: a computational study”.

### BIOGRAPHY

I received my BSc in Physics in 2011 and my MSc in nuclear and subnuclear physics (cum laude) in 2013 from University of Trieste, Italy. My MSc project was done in collaboration with a group of physicists at SISSA (International School for Advanced Studies) on a computational model for grid cells. After graduation, I was awarded a six months’ postgraduate fellowship from SISSA to continue my work on the formation of spatial representations on hyperbolic surfaces. I have joined the Neural Interfaces group at the Centre for Bio-inspired Technology as a PhD candidate in August 2014.

### RECENT PUBLICATIONS AND KEY REFERENCES

F Troiani, K Nikolic, T G Constandinou, “Optical coherence tomography for detection of compound action potential in *Xenopus Laevis* sciatic nerve”. *Proc. SPIE*, vol. 9690, pp. 96901F1-7, 2016.

F Troiani, K Nikolic, T G Constandinou, “Optical coherence tomography for compound action potential detection: a computational study”, *Proc. SPIE*, vol.10416, pp. 104160A, 2017.

L B Cohen, R D Keynes, B Hille, “Light scattering and birefringence changes during nerve activity”, *Nature*, vol. 218, pp. 438–441, 1968.

D Huang, *et al.*, “Optical coherence tomography”, *Science*, vol. 254, no. 5035, pp. 1178–1181, 1991.

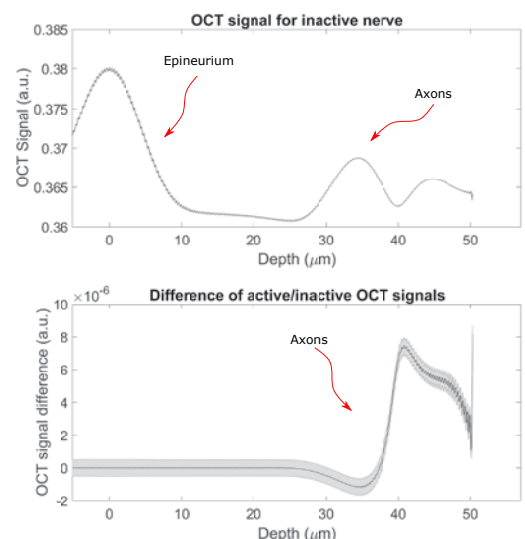
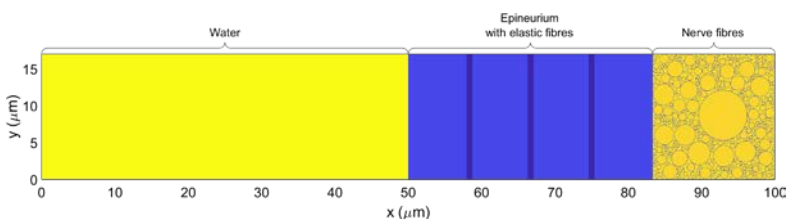



## Siwei Xie

### Research focus

Embedded system design for real-time image processing and data transmission based on compressive sensing and wireless sensor networks

### Supervisor

Prof Chris Toumazou

### MOTIVATION

Nowadays, image processing is helping in numerous ways for the researchers and developers to achieve their specific goals. Therefore, the efficient image processing algorithms have been rapidly developed. Although several signal compression algorithms can be used to reduce the complexity of capturing, analyzing or storing the signals, which can diminish the processing time, memory size and the power requirements, the requirements are still strict for wearables to implement the whole process and few chips are used to process the image scaled signals especially with high speed response on low-powered wearable devices.

Therefore, the main purpose of this research is to quickly and correctly capture the “compressed signals”, speedily analyse and output data inside low powered and small sized hardware architecture instead of using computers or GPUs. Meanwhile, this project aims to combine wireless sensor networks technology, which can quickly connect multiple portable and wearable devices into a network and share information with high transmission rate, low error rate and low power cost.

### OBJECTIVES

- Compressing the image scaled signals with compressive sensing (CS) technology.
- Designing a low powered, fast responded lensless imaging system to capture the “compressed signals” and balancing trade-offs.
- Building wireless sensor networks (WSNs) for data transmission among wearables, improving the reliability and higher the transmission rate with low power consumption.

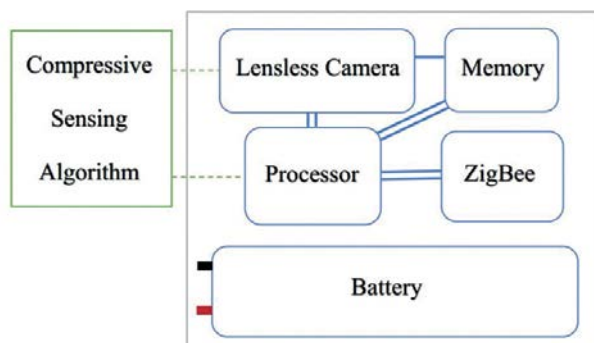

Entire system overview

### BIOGRAPHY

Siwei Xie is a first year PhD student with the background of system control and embedded system design. She received the Master degree in Electrical & Electronic Engineering from University of Leicester (2015). After the graduation, she went back to Beijing and worked in CapitalBio as a biomedical engineering developer. With this one-year developing experience and her previous study, she started her PhD research in Imperial College of London (2016). She is now focusing on analog and digital circuits design for self-healthcare devices. The main research interests of Siwei include image processing, data communications and FPGA design. The aim of her research is to give people a better using experience with customized and private health-care recommendations provided by personalised wearables.

### RECENT ACHIEVEMENTS

- Understanding the project related, advanced techniques. They are compressive sensing (CS), lensless imaging and wireless sensor networks (WSNs).
- Improving my technique skills in digital circuits design. Using SPI, SCCB, USART, MIPI to design camera-based wearables.
- Using platform with ARM core and reduce the system size.
- Building a ZigBee network to obtaining the power consumption, transmission rate and working range.
- Comparing three wireless sensor network communication protocols and balancing trade-offs.



ZigBee module setup

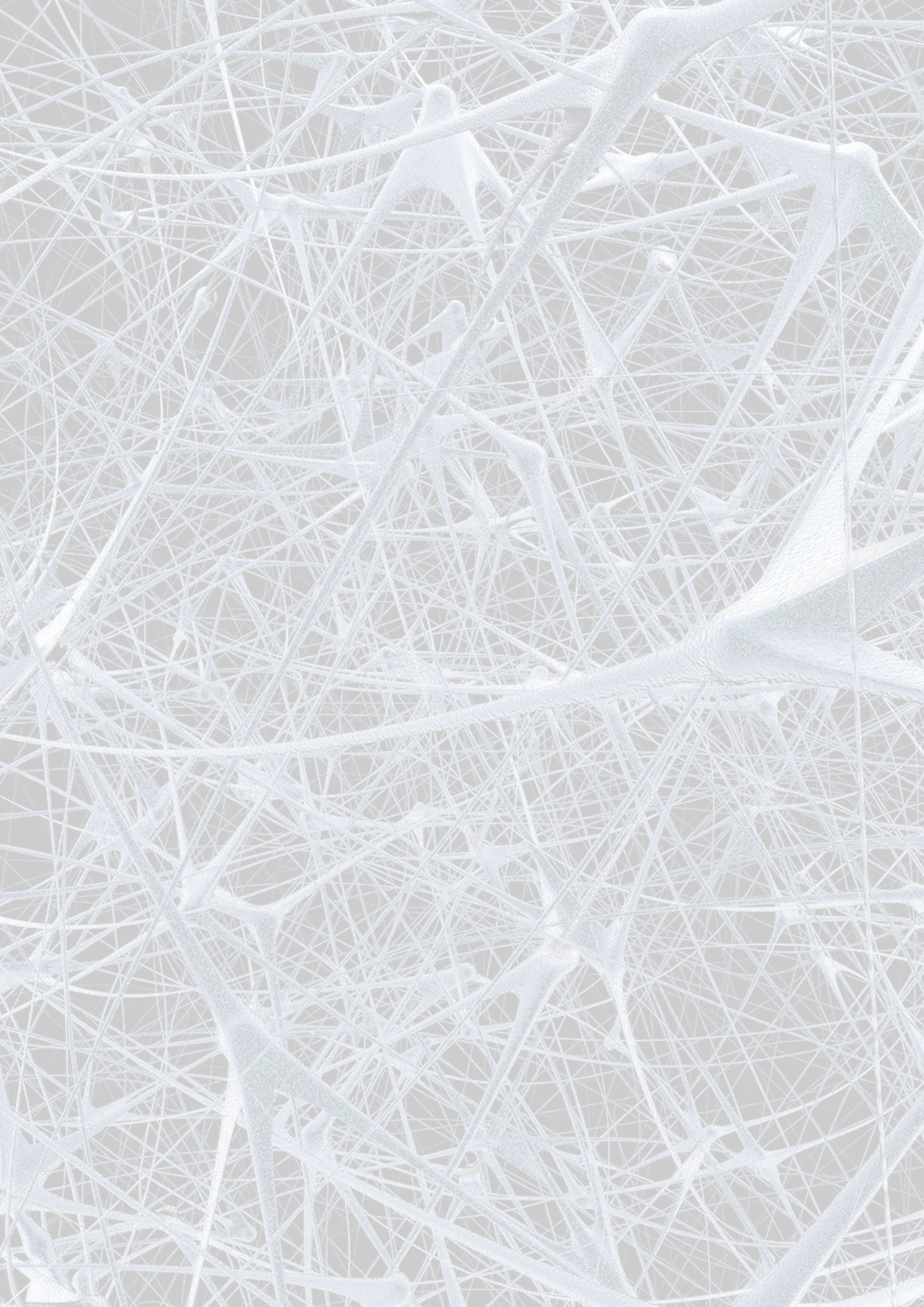



# Imperial College London

Centre for Bio-Inspired Technology  
Department of Electrical  
and Electronic Engineering  
Imperial College London  
South Kensington  
London SW7 2AZ

T +44 (0)20 7594 0701  
F +44 (0)20 7594 0704  
bioinspired@imperial.ac.uk

[www.imperial.ac.uk/  
bioinspiredtechnology](http://www.imperial.ac.uk/bioinspiredtechnology)

 @ImperialCBIT