

Imperial College London

**Information & Communications Technology
Network Infrastructure Delivery**

**Network Infrastructure Standards
April 2020**

Version 1.6

Revision History

Version	Date	Author	Description
Draft	12/03/2007	Antonio Barbosa	Initial document
1	13/06/2007	Matthew Williams	Revisions
1.1	30/05/2008	Antonio Barbosa	Small revision on all appendixes (except appendix J - AV). Sent to Networks group for comment.
1.2	17/03/2010	Antonio Barbosa	Small revision on most appendixes. New products and revised specifications.
1.3	03/07/2013	Antonio Barbosa Margaret Chambers	Contact updates. New contractors, fire strategy and minor updates.
1.4	30/11/ 2016	Margaret Chambers Antonio Barbosa	New Contractor matrix and revisions on several appendixes.
1.5	30/01/2018	Antonio Barbosa Margaret Chambers Tania Bozinovska	Update changes to most document. Most noticeable the inclusion of an external infrastructure appendix, Optical Distribution Frames and their implementation strategy changed, Inclusion of new CPD regulations and new cabling. Containment improvements and comms rooms power.
1.6	20/04/2020	Nick Jones Tania Bozinovska	Changes to entire document, inclusion of CPR regulations.

Distribution

Who	Role
ICT	
Juan Villamil	CIO
Paul Jennings	Head of Service Operations
Estates Division	
Nicholas Roalfe	Director of Estates Operations
Adam Srodzinski	Head of Projects
Richard Farish	Head of Building Operations
Roy Dickerson	Strategic Infrastructure Manager
Andy Hammond	Head of Engineering, Energy and Environment
Paul Felton	Quality Assurance
Sean Fanning	Chief Fire Officer
Terry Branch	Head of Security
Others	
ICT Preferred contractors	See Appendix A
Estates Framework	Framework contractors (distribution by Estates)

Table of contents

- 1.0 Introduction**
- 2.0 Scope**
- 3.0 Naming Conventions**
- 4.0 College Infrastructure Overview**
- 5.0 ICT Roles and Responsibilities**
- 6.0 Project Roles and Responsibilities**
- 7.0 Project Scope**
- 8.0 College Data Outlet Design Requirements**

Appendix A – Approved Contractors

Appendix B – CWC Fitout Requirements

Appendix C – Cabling Specification and Installation

Appendix D – External Infrastructure Specification and Installation

Appendix E – Ordering Information

Appendix F – Contractors Responsibility Matrix and Handover

1.0 Introduction

This document sets out the standards for the design and installation of all Imperial College London ICT network infrastructure including:

- BAU installations including Add, Moves and Changes.
- Emergency installations and maintenance of the network infrastructure.
- Refurbishment projects of College offices, lecture theatres, labs, student halls etc.
- New College building construction.

The ICT Network Infrastructure Delivery (NID) Team acts as College Duty Holder for all installation of the College network infrastructure and implementation of these standards. The team works with carefully chosen suppliers and contractors as well as College Estates Engineering, Building Operations and Project teams to deliver world class infrastructure.

2.0 Scope

Information contained in this document and associated appendixes will prove useful to architects, electrical/data/telecommunications consultants, main contractors, suppliers, installers or anyone responsible for the design, specification, planning or installation of College network infrastructure.

The importance of following ICT Network Infrastructure Standards and structured cabling principles is twofold:

- ICT connectivity should be viewed as essential, business critical service and any interruptions to the infrastructure can have serious impact on all College users.
- College buildings lifespan could be several decades, it is essential that the planning, design and construction of a new or refurbished building be done with due care to enable College current and future effectiveness.

All relevant British Standards and Codes of Practice shall apply, and this document does not replace industry-standard design guidance or practice. It is intended to provide the College's requirements for ICT network infrastructure design and installation.

3.0 Naming Convention

Throughout this document the following naming convention particular to the College have been used:

CWC	Communication and Wiring Centre from which the distribution of data and voice is done and houses active and passive equipment to enable network connectivity.
Active equipment	All equipment that enables network connectivity: switches, routers, WAP. Also, security swipe access control panels, UPS/RPS systems, environmental monitoring systems, computer equipment, telephones.
WAP	Wireless Access Point (WAP), includes all necessary infrastructures to support the equipment itself.

All other definitions and abbreviations are as per the relevant British Standards as noted in Appendix C – Cabling Specification and Installation.

4.0 College Network Infrastructure Overview

Incoming Telecommunication Service

Incoming telecommunications services provided by utility service providers connect in 'meet me' rooms / cabinets at locations at the perimeter of the College campus. These 'meet me' rooms / cabinets are installed in strategic locations to enable multiple entry points into the campus so that a range of routes and telecoms operators can be used to provide connectivity.

Meet me rooms are diversely connected via backbone fibre optic cabling running through ICT OSP (Outside Plant) network infrastructure to required network core locations.

If no 'meet me' locations are on campus, intake rooms can act as the telecommunications providers entry point.

The College ICT OSP Network Infrastructure comprises of numerous chambers and ducts and any new additions to these will need to be planned in collaboration and agreed with Estates Strategic Infrastructure plans.

Please refer to Appendix D – External Infrastructure Specification and Installation for more detailed information and College standards for installation.

Backbone Fibre Optic Infrastructure

Each building will have two intake rooms to receive external and internal dual diversely routed backbone fibre optic cabling for connection to the site wide network.

Intake rooms will be small areas where the ducts or tunnels join the building. Access ducts entering these rooms will be unobstructed, accessible to ICT engineers and utility service providers personnel and will contain the following:

- ODF (Optical Distribution Frame).
- 108a frame for multipair copper (for BT and similar services) if required.

Intake rooms will serve as a fibre aggregation location from where internal backbone fibre cabling will be installed via two different routes to diversely connect all CWCs within a building.

An intake room and main CWC could be one room.

Horizontal Cabling Infrastructure

CWCs within buildings will provide horizontal distribution cabling to individual data outlets on each floor. Locations for CWCs will be determined according to current building strategy and cabling zones as set by ICT NID Team.

Horizontal cabling routes cannot exceed 90m.

One CWC can only serve one cabling zone, however this can be over several building floors. The sizing of the CWCs will take into consideration maximum number of data outlets per cabling zone.

For more detailed information on the type, specification and installation requirements of backbone and horizontal cabling please refer to Appendix C – Cabling Specification and Installation.

College Network Infrastructure Topology Diagram

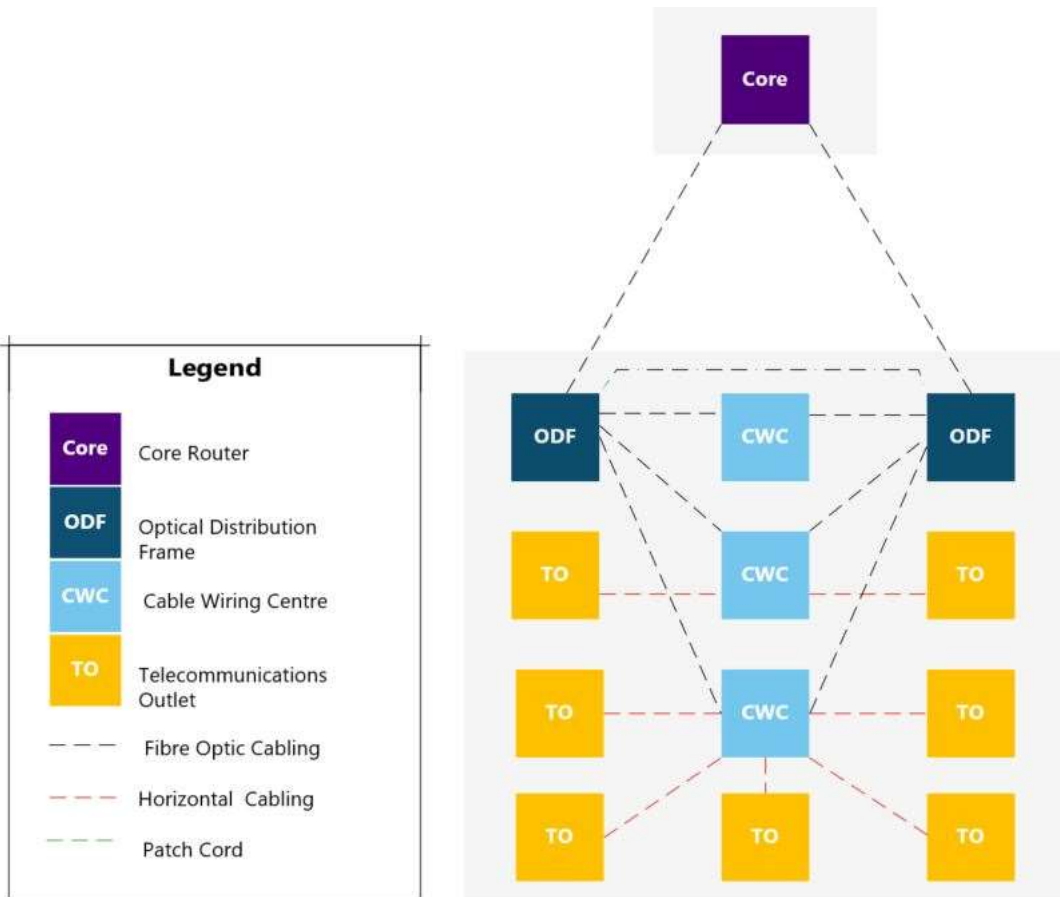
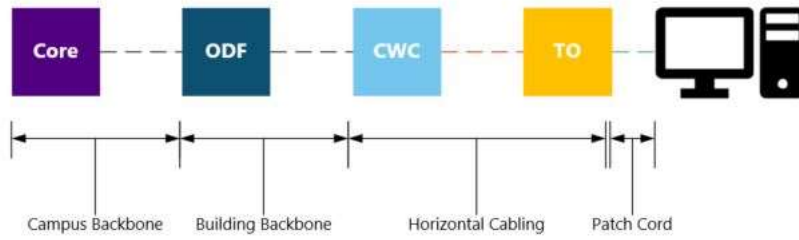

5.0 ICT Roles and Responsibilities

The College continually embarks on numerous projects and activities to improve student learning and user experience. These projects can affect the College network infrastructure and can impact the users network connectivity.

ICT Network Infrastructure Delivery Team is responsible for the design, specification and approval of overall ICT connectivity requirements in any project involving any changes to the College network infrastructure and will provide the following:

- Dedicated resource that will act as the ICT department's stakeholder.
- Support and guidance as well as translating logical design into a schedule of construction requirements to be incorporated into the Project by the Design Team.
- Conduct survey and issue ICT report to include costs of any active equipment.
- Procure and supply all active network equipment required.
- Configure and install all active equipment.
- Enable connection to the rest of the network.
- Advise on telephone services.
- Advise on AV services.
- Advise Estates on BMS, Security, Fire and any other services requiring connectivity to the College network.
- Ongoing day-to-day support and maintaining the network infrastructure.

6.0 Project Roles and Responsibilities

In order to minimise any ambiguity, it is recommended the responsibilities of the design, specification, planning and installation of each project be clearly defined.

It will be the Project Manager's responsibility to request from the ICT Duty Holder a sign off on each stage of the project. Failure to do so may cause the project to be unable to deliver infrastructure conforming to the ICT Network Infrastructure Standards. In extreme cases this may result in it being impossible to connect the to the remainder of the College's network.

Estates Building Operations Team

NID Team act as principle designers for small refurbishment projects and any adds / moves / changes need to be approved before appointing contractors.

Building / Project Manager responsibility is to:

- Contact the NID Team at design stage to clarify requirements and approve design.
- Inform when area is vacated and request removal of active equipment.
- Inform of any power isolations affecting College network.
- Provide user patching schedule to ICT or approved cabling contractor for connecting users to the College network.

Estates Projects Team

Project Manager or M&E Consultant responsible for the design, specification, planning or installation of the network infrastructure is required to engage the NID Team to clarify requirements, advise and approve on design and installation.

The following table is to be used as a guideline for engaging the team at different stages of the project.

Project Stage		NID Team involvement
Stage 0	Strategic definition/Prefeasibility	Keep informed
Stage 1	Preparation and brief	Keep informed
Stage 2	Concept design	Consulted on design
Stage 3	Developed design	Consulted on design
Stage 4	Technical design	Approve final design
Stage 5	Construction	Engaged as supervisors
Stage 6	Handover and close out	Witness test & sign off ICT element
Stage 7	In use	BAU activities

7.0 Project Scope

The standards should be strictly followed, and any clarifications should be made by a request for information to the Network Infrastructure Delivery Team.

It is the responsibility of the project to deliver a network infrastructure which complies with ICT Network Infrastructure Standards.

For a full and detailed explanation of all the items that are mandated during project please refer to the appendixes to this document and as specified below:

Project Scope	Full detailed information
Appointing ICT contractors / consultants	Appendix A – Approved Contractors
CWC and intake room specification	Appendix B – CWC Fitout Requirements
Identifying cabling routes	Appendix C – Cabling Specification and Installation
Installation of:	
-Containment	
-Backbone cabling	
-Horizontal cabling	
-Ez Paths	
Terminating & Labelling	
Testing & Commissioning	
Documentation	Appendix E – Ordering Information
User patching	
Specification and procurement of:	
-Structured Cabling Components	
-Containment	
-Patch cables specification and procurement	
-Cabinet specification and procurement	
-Passive Equipment	Appendix D – External Infrastructure Specification and Installation
Active Equipment Specification	
Chambers & Ducts Specification and installation	Appendix D – External Infrastructure Specification and Installation
Identification and labelling	

Appendix F – Contractor Responsibility Matrix outlines the obligations of all parties engaged in the network infrastructure installation.

Project Handover – Please contact ICT NID Team for detailed checklist used to for handover and sign off of completed CWCs, fibre and CAT6A cabling installations.

8.0 College Data Outlet Design Requirements

Regardless of data outlet designation (VoIP, data, WAP, AV, CCTV etc.), the project manager shall **ensure ALL data requirements are shown on one data design drawing to be approved by ICT Network Infrastructure Delivery Team.**

The design of horizontal cabling subsystem should provide for a minimum of two data outlets per work area as per EN 50173-2. However, each user / department in College will have different requirements, design and final numbers will have to be agreed with Network Infrastructure Delivery Team at design stage.

The main user types and number of data outlets per device and space type have been defined below as the minimum requirements for outlet concentration.

Device Type	Standard data provision for device type
BEMS Controller	No of Devices as per design + 1 data outlet
CCTV	2 data outlets per CCTV location
Access Control	2 data outlets per controller
Fire Alarm	2 data outlets per panel
Lift	1 x CW1308 per lift car, 2 x data outlets per lift
Wireless AP (WAP)	2 data outlets HL per WAP
Screen	2 data outlets per screen
Printer	2 data outlets per printer
AV	Data outlets as per AV design

Space Type	Standard data outlets provision for space type
Plant room	4 data for metering
LV switch room	4 data for metering + 1 x CW1308
Intake room	No data outlets
CWC room	2 data + any controller devices
Office	2 data per person or as agreed by users at design stage
IT Office	4 data per person
Reception	4 data per desk
College Common Space	Wi-Fi as per College design + 4 data
Study area	Wi-Fi as per College design + 2 data
Student breakout	Wi-Fi as per College design + 2 data
Pod	2 data per pod
Meeting Room - up to 4 persons	2 data per screen + 2 data
Meeting Room - up to 16 persons	Depending on size and per ICT AV & Wi-Fi design
Teaching space	Depending on size and per ICT AV & Wi-Fi design

Appendix A –Approved Contractors

Contractors Services:

Imperial College London undertakes a wide range of refurbishment, redevelopment, and new build projects to maintain its status as one of the top higher education institutions in the United Kingdom and worldwide.

ICT maintains a list of Approved contractors to deliver the College passive and active infrastructure and provide user connectivity to the College network. Service provided by the ICT contractors include the following:

General Cabling Services

- Survey and reporting of existing infrastructure.
- New cabling installations.
- Removal of old cabling and equipment not up to current ICT Network Infrastructure Standards.
- Removal of wireless and other services and equipment as agreed with NID Team.
- Patching.

User Moves

- Office / Department moves, providing hand on support including surveys of existing workspaces, removing and re-instating equipment.
- Patching.
- Provide resources post move and day one support.

Business As Usual (BAU) Work

- These works will be managed by ICT NID Team and may comprise the Service Desk requests for small installations and general remote hands support as well as larger ICT infrastructure improvement projects.

Design

- ICT Network Infrastructure Delivery Team will act as designers and supervisors on most projects, however on large construction projects complexity of the work requires specialist knowledge that can assist the projects in the design process. Any design will need to be agreed and approved by NID Team.

Contractors Services Matrix				
	General Cabling	User Moves	BAU	Design
A-Tech	✓	✓	✓	
Kinetic IT	✓	✓	✓	
ACS	✓	✓	✓	
Excel Redstone	✓	✓		✓
Trescray	✓	✓		✓
Hoare Lea				✓
Cordless				✓
AECOM				✓
PTS				✓
Mix Consultancy				✓

Contacts

The ICT Network Infrastructure Delivery Team email: ictns-infra-dl@imperial.ac.uk

The list of approved companies is as follows (Alphabetically):

A-Tech Data Solutions

Unit 44, Hoddesdon Industrial Centre, Pindar Road, Hoddesdon. EN11 0FF

<http://www.atechdatasolutions.com>

sales@a-tech.it

Brian Ellis

Account Director

Tel: 0203 640 1040

brian.ellis@atechdatasolutions.com

Amy Offord

Finance Manager

amy@atechdatasolutions.com

ACS

47 Grand Avenue, Camberley, Surrey. GU15 3QJ

sales@acsvs.co.uk

Chris Flaherty

Director

Mob: 07837 826098

chris@acsvs.co.uk

AECOM

63-77 Victoria Street, St Albans, AL1 3ER

www.aecom.com

Tony Buckingham

Regional Director- ITC Group

Tel: 01727 535360

Mob: 017921 646273

tony.buckingham@aecom.com

Cordless Consultants Limited

2 Queen Anne's Gate Buildings, Dartmouth Street, London. SW1P 4AX

www.cordless.co.uk

Steve Jarvis

Account Manager

Mob: 07775 448094

steve.jarvis@cordless.co.uk

ExcelRedstone

40 Holborn Viaduct, London EC1N 2PB
www.excelredstone.com

Natalie Shields
(Business Manager)
Tel: 0203 929 9915
Mob: 07973 246096
Natalie.Shields@excelredstone.com

Matt Salter
(Sales Director)
matt.salter@excelredstone.com

Hoare Lea Intelligent Buildings

Western Transit Shed, 12-13 Stable Street, London, N1C 4AB
www.hoarelea.com

Magnus Leask
Senior Associate
Tel: 020 3668 7374
Mob: 07795 567 615
magnusleask@hoarelea.com

Kinetic IT

Unit 75 The Base, Dartford Business Park Victoria Road, Dartford, Kent. DA1 5FS
www.kineticit.net

Nolan Chock
Bid and Design Manager
Tel: 03333 661155
nolan.chock@kineticit.net

Mix Consultancy

St Clements House, 27 Clements Lane, London, EC4A 7AE
www.mixconsultancy.com

Adam Oliver
Commercial Director
Tel: 020 3319 1600
adam.oliver@mixconsultancy.com

PTS Consulting Partners LLP

60 New Broad Street, London. EC2M 1JJ
<http://ptsconsulting.com>

Mark Perrett
Account Manager
Tel: 0330 313 6241
Mob: 07947 346 340
mark.perrett@ptsconsulting.com

Appendix B – CWC Requirements

Introduction

The international standards defining structured cabling for data systems dictate that the maximum length of a main link cable should not exceed 90m.

When installing structured cabling systems within buildings, it is necessary to logically divide the building into one or more individual cabling zones.

At the heart of each cabling zone is a CWC which contains equipment cabinets providing termination and racking space for cabling, voice, fibre optic and active data equipment services. **Maximum length of a main permanent link cable should not exceed 90m.** Typically it should not be more than 60m away from the furthest point to safely guarantee cable performance to allow for the routing of the cable.

Cabling zone can only be served by one CWC.

Equipment Cabinet capacities

The design of horizontal cabling subsystem should provide for a minimum of two data outlets per work area as per EN 50173-2. However, each user / department in College will have different requirements, design **and final numbers will have to be agreed with NID Team at design stage.**

The main user types and number of data outlets per device and space type have been defined in the main standards document that accompanies this appendix as the minimum requirements for outlet concentration.

Cabinet should be sized to allow for extra 40% capacity for future expansion.

This specification will enable the initial calculations for the number of cabinets needed per floor and therefore the size of the CWC required.

Room construction and fit out

These are strict specifications for size and construction of College CWCs and any deviation should be approved by Network Infrastructure Delivery Team.

Complete fit out and official project handover of CWC is required for ICT to approve install of any active equipment.

CWC fitout and handover should be scheduled before commissioning of BMS and Security Services.

The room must be cleaned prior to handover. Any subsequent work will imply cleaning the CWC at contractor / project cost.

Construction Specifications	
Construction	To provide a minimum 1 hour fire rating. (Imperial College Regulations = 30mins)
Access	Access to the CWC must be from a corridor and completely unrestricted.
Room Height	Minimum 2.4m throughout. No raised floor or false ceiling to be installed.
Wall Covering	Painted / low dust, anti-static
Floor covering	Low dust and Anti-static finish. No carpets or bare concrete screed will be accepted.
Wet Services	No wet services within or running through room. If there are wet services in the vicinity appropriate measures must be taken to prevent water ingress in the room. Data cables will not run in the same risers as wet services.
Dado Containment	No dado containment within CWC. All power services to be provided on standard back-boxes (Wall Mounted, Floor or Sub-Floor).
Door(s)	Minimum opening per door 840mm (W) x 2200mm (H).
Security	Aperio E100 or L100 Access Control to be fitted with an ICT override cylinder as per the Building Engineering Services Particular Requirements (BESPR's). Keypad combination locks shall not be fitted. Room designation on doors will be CWC XXX (where XXX is a number allocated by ICT) and room number. No further description should be written on the door. Contact ICT for CWC ID information. "Permit to work area" notice is also required, provided by ICT.
Other:	The room should not be located in a location accessible from the outside through a window. If no other suitable location is found and such solution is sanctioned by ICT some actions should be taken: Secure the window against external access. Make the window weatherproof so that: <ul style="list-style-type: none"> - There is no temperature gain from sun exposure - No water or humidity can ingress - No condensation can accumulate - UV coating or film to prevent UV damage to cabling The room cannot have a door to the outside of the building. A hard plastic pouch for documents should be placed within the room. 4 no. J-Hooks to be installed on the wall for patch cables storage. See Appendix E – Ordering.

Power, Light & Temperature	
Electrical:	<p>Each CWC room shall be provided with a dedicated distribution board, complete with type C miniature circuit breakers (MCB's). The final circuit provision from this distribution board shall be as follows:</p> <p>2No. 16amp unswitched BS EN 60309-1 (BS 4343) socket outlets per cabinet. (Location to be confirmed by ICT). Socket outlets to be as manufactured by MK Electric, selected from their `Commando` range.</p> <p>1No. 13amp 2 gang switched socket outlet. (Height and location to be agreed with ICT).</p> <p>An earth bar complete with a test link connection. Number of connections available to equal number of cabinets installed plus an allowance for future cabinets, as agreed with NID Team.</p> <p>All cabinets to have their frame connected to the earth bar.</p> <p>All socket outlets to be labelled with a circuit reference.</p> <p>1No. 32 or 63 amp switched interlocked BS EN 60309-1 (BS 4343) socket outlet to be provided per router location (it is recommended that this supply is served from the distribution board in the CWC room). Socket outlets to be as manufactured by MK Electric, selected from their `Commando` range.</p> <p>At least 2 to 3No. of the spare ways in the DB should be wired to fused connection units located adjacent to the DB for future connections of equipment's without the need to turn off the DB.</p> <p>Each cabinet to be provided with 2 no. 16 amp commando-type socket outlets to B EN 60309 on dedicated circuits, to be protected by 16A Type C MCBs. They will be connected to power bars inside cabinets with 12 no. 13 amp sockets (leads to be fed overhead).</p> <p>During a construction of a CWC power will be installed considering the maximum number of cabinets possible to be installed in the space.</p> <p>1 no. wall-mounted dual 13 Amp switched gang for dirty power requirements, provisioned from standard electrical ring.</p> <p>Sockets supplying CWCs to be mounted at high level above cabinets.</p> <p>All electrical work to be completed as per Estates Building Engineering Services Particular Requirements.</p>
Earth:	High integrity earthing will be supplied as per IEEE 18 th edition specifications and Estates Technical Policies Specifications.
Lighting:	500 Lux at floor level, locally switched & Emergency lighting. This will be in line with the Estates BESPR's.
Temperature:	Minimum 18 degrees C to Maximum 24 degrees C. To be monitored with a Trend temperature sensor via the BEMS and displayed appropriately on the Trend building management system server. Appropriate alarms are to be generated if the conditions drift from the above-mentioned parameters.

	<p>An air-conditioning unit should be provided to maintain environment, run and fault signals should be monitored and displayed via the BEMS to ensure good functioning at all times.</p> <p>The air-conditioning unit will be resettable via the BMS system.</p> <p>All Air conditioning units should operate 24/7 and be programmed to resume after any failure (either the unit's or power).</p> <p>A Router locations CWCs require resilient air-conditioning unit due to location criticality. These are to be controlled / monitored via the BEMS and displayed appropriately on the Trend building management system server. Appropriate alarms are to be generated for fault condition.</p> <p>Any condensate pumps to be sited outside the CWC.</p> <p>The alarms will be sent via email to the FM team and to the Network Infrastructure group on ictns-infra-dl@imperial.ac.uk</p>
Humidity:	30% to 60% non-condensing.
Heat Generation:	<p>Currently Juniper EX4300-48P switches should be considered http://www.juniper.net/assets/us/en/local/pdf/datasheets/1000467-en.pdf , with estimated requirement maximum of 10 units per cabinet should be considered when calculating loads and requirements of the CWC.</p> <p>In each router location an installation of SRT5KRMXLI (5kva) UPS to be considered.</p>
Other:	No heat exchange or other services that might influence room temperature may be within or running through the room. Other than the local CWC Distribution Board (DB) no other DB should be within the room. No water services should be routed in or through the CWC.
Fire Detection & Suppression	
Fire Detection	Appropriate Fire Detection is to be installed within the room, and connected to the Fire Detection and Alarm System.
Fire Suppression	No wet automated fire suppression to be installed.
Cable Entries	All cable entry holes are to be appropriately fire stopped in accordance with the appropriate standards. EZ-paths to be used where possible. All new CWCs will be fitted with Ez-Path cable routes for data cables. This will be done taking into consideration future capacity for expansion, meaning that on all comms rooms the first installation of EZ-Paths will be sized to enable the installation of cables for the full capacity of the room. This will prevent further drilling and dusty works. Legacy CWCs will be fitted with these when they are part of the building strategy (please contact NID Team for information). Ez-Paths are to be installed by accredited Contractors
Miscellaneous	
Cable Entries	All cable entry holes to be sleeved.
Containment	Minimum 600mm cable tray from room entry point to the cabinet(s).

CWC Sizing

The size of the CWC will be directly linked to the number of floors served, total gross area, number of people using the services, type of CWC and space allocation.

The following sizing rules will be applied:

- All cabinets will be installed in a line.
- There will be 1,000mm of free space around the line of cabinets (front, sides and back).
- Cabinet size is 800(W) x1000(D).

College CWC locations can be as follows:

- **Standard**; location will be used for copper cable distribution.
- **Fibre aggregation**; location will be a point to which all standard CWC's link back to via backbone fibre. The fibre aggregation is usually done in 1 or 2 cabinets or an ODF depending on the size of the building and number of CWCs.
- **Router**, building or core router in the location. Extra cabinets might be required. Please consult with ICT NID Team.

Cabinets

For detailed specification and part codes, see appendix E – Ordering.

- All cabinets should be of 42u with 800 x1000 footprint;
- The cabinet should be earth bonded in accordance with IEE 18th Edition.
- A cabinet baying kit to facilitate the baying together of multiple cabinets.

Labelling

Each equipment cabinet should be labelled with ICT's CWC identification code in the format "CWC xxx Cabinet yyy" where xxx is the CWC number and yyy is the local cabinet designation A, B or C etc where multiple cabinets exist (or may exist) in the same CWC.

All cabinets will be labelled with trifoliate type laser engraved label.

Patch Cable Management

24-way angled panel (1U 24) are used as standard. For part code, see appendix E – Ordering.

- One no. 1u horizontal cable management bar following each 4u of fibre patch panels;
- One no. 1u horizontal cable management bar following each 1u (48 ports) active data switch;
- One no. 1u horizontal cable management bar before each voice panels.

42U cabinet layout example

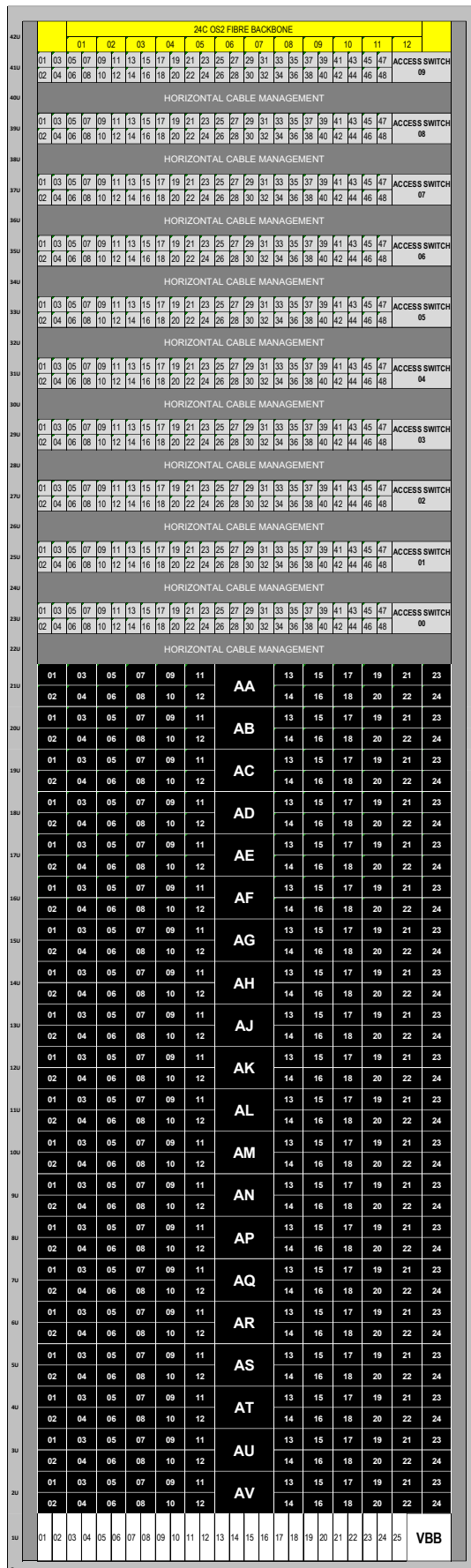

Appendix C

Cabling Specification and Installation

Introduction

This Section details the required standards for (SCS) structured cabling systems to be installed as part of the College Network Infrastructure.

Structured Cabling Standards

All installation works must be undertaken in line with applicable standards and manufacturer's installation instructions:

- BS EN6701:2016+A1:2017 Telecommunications equipment and cabling
- BS 7671:2018 IET Wiring Regulations (18th Edition)
- ANSI/TIA/EIA 568-B Commercial building telecommunications cabling standard
- BS 7430 Code of practice for protective earthing of electrical installations
- BS EN 50173 Information technology – Generic cabling systems
- BS EN 50174 Information technology – Cabling installation
- BS EN 50310 Telecommunications bonding networks for buildings and other structures
- BS EN 50346 Information technology – Cabling installation – Testing of installed cabling
- BS EN 60874-1 Fibre optic interconnecting devices and passive components – Connectors for optical fibres and cables
- BS IEC 61000-5-2 Electromagnetic compatibility (EMC) – Part 5: Installation and mitigation guidelines – Section 2: Earthing and cabling
- NJUG National Joint Utilities Group – NJUG Guidelines – Volumes 1 to 6
- All current and relevant ISO/IEC, CENELEC and ANSI/TIA/EIA standards

As a minimum, the CAT6a SCS must support the following transmission requirements:

- IEEE 802.3 Ethernet (10BaseT), Fast Ethernet (100BaseTX) and Gigabit Ethernet (1000BaseT and 10Gbase-T)
- IEEE 802.3 Type 1 / Type2
- EIA RS 232-D (asynchronous)
- 100 Mbit/s services - i.e. TPDDI/CDDI/TP-PMD
- ATM standards (ATM25, ATM52, ATM155 & ATM1200)
- Analogue and Digital Voice Telephony

As a minimum, the CAT5e SCS must support the following transmission requirements:

- IEEE 802.3 Ethernet (10BaseT) Fast Ethernet(100BaseTX) Gigabit Ethernet(1000BaseT)
- IEEE 802.3 Type 1 / Type2
- EIA RS 232-D (asynchronous)
- 100 Mbit/s services - i.e. TPDDI/CDDI/TP-PMD
- ATM standards (ATM25, ATM52, ATM155)
- Analogue and Digital Voice Telephony

All materials shall be new and of types approved by ICT NID Team (see information in “Appendix E – Ordering”), BABT and the BSI for their intended use. Attention is drawn to the selection of the appropriate cables for each type of installation environment.

The colour of the cable will comply to manufacturer's and industry standards.

All installation works must be undertaken in line with applicable standards and manufacturer's installation instructions.

Attention should be paid to cable segregation, cable fixing spacing and defined cable routes in under floor routes.

The above standards should be the minimum acceptable standards.

Cable Routes

All cables with their origin and destination within the same building shall be run internally.

Where there is a requirement to run externally for OSP (Outside Plant) applications i.e. CCTV BMS then a transition point will be permitted to allow for the use of external grade cable. External grade cable not to run more than 2m internally. (Total length not to exceed 90m).

All cable routes should be agreed with NID Team before commencement of their installation.

All routes will follow public spaces for easy access after project completion and hand-over.

All vertical cables shall be secured to installed tray at the intervals recommended by the manufacturer. Contractors should confirm their intended method of securing the cables.

No cables will be left un-supported.

Any installation of cabling in raised floors shall be done in no less than in a space of 300mm of height and within the appropriate containment. Any changes to this specification should be explained to and accepted by NID Team.

All containment will have labels saying "ICT DATA CABLES" every 5 metres and every concealment point.

No other cables are permitted in the containment.

Within a CWC the cables will be installed in such a way that they will allow cabinets to be moved if required.

Horizontal cabling Installation

To ensure consistency across the College, only the following cabling systems can be used.

Leviton CAT6a U/FTP CCa - Our preferred cabling system. It will be mandatory that all new buildings be installed with this cabling type.

Excel CAT5e U/UTP B2Ca - Only to be installed in circumstances where a compliant CAT6a solution cannot be achieved. (please contact Imperial NID for clarification)

Further information on ordering can be found within Appendix E.

Installation Requirements

All cables shall be installed in accordance with latest issue of BS EN50174 and the manufacturer's instructions and recommendations. Care should be taken to ensure the minimum bend radius is not exceeded thereby preventing kinks in the cable construction.

Power and data separation must be adhered to, as a guide please use the table below;

Segregation Classification	Cable Class	Cable Containment System			
		None or Non-Metallic	Open metallic containment	Perforated metallic containment	Solid metallic Containment
B	Class D or E or EA U/UTP	100mm	75mm	50mm	0mm
C	Class D or E or EA U/FTP	50mm	38mm	25mm	0mm

All cabling shall be loomed into maximum looms of 24 cables. Looms shall be **Velcro** wrapped to cable basket in accordance with manufacturer's installation instructions, where CAT5e U/UTP is in use nylon cable ties will suffice. Cable looms should be maintained to the equipment cabinet within the CWC. Care should be taken not to crush cables by over tightened fixings. If metal type cable ties are used to comply with fire regulations ensure excess tail is cut flush, to avoid the creation of sharp and dangerous edges.

All rooms will be fed from a single comms room, there will be absolutely no mixing of cabling from two or more comms rooms, into the areas in need of connection.

Any installation requiring replacement of old cabling will imply its removal as an integral part of the work and to be included in the of the project specifications.

Any de-commissioning of cable or user outlet termination requires the complete removal of the cable back to the CWC presentation panel as a part of the work and to be included in the of the project specifications.

Any work within ceilings or under floor must be made good prior to completion.

Cable Lengths

All cables shall not exceed 90 metres in length. CWC's should be strategically located to allow for this. All 4 pair cables should be continuous between the Patch Panel in the CWC and the user outlet at the User Connection Point. All cables should be installed within the containment provided or specified.

Installation of cabling within cabinets

All cables should be neatly installed and secured collectively to the Cabinet or Frame, from the point of entry to the point of distribution across the rear of the patch panel.

All cables installed we have a service loop to increase flexibility in cabinet relocation or movement (emergency or unforeseen events).

It is acceptable for the cables to be dressed as either, 24 cables from one side or split as 12 from each

All patch panels will be grounded for electrical safety.

Patch Panel Specification

All patch panels should meet or exceed the transmission performance requirements for Twisted-Pair Connecting Hardware defined by the standard or the BS EN 50173 Commercial Building Telecommunications Wiring Standard ANSI/EIA/TIA-568B where this standard exceeds BS EN 50173.

Patch panels, outlets, main link and patch cables should be selected from a single manufacturers system.

Patch Panel Terminations

All four pairs of the cable shall be terminated onto the rear of the patch panel via Insulation Displacement Connection (IDC) techniques.

The horizontal cables shall be terminated as per the EIA/TIA 568B wiring scheme so that the presentation of the cable pairs on the RJ45 socket are as follows:

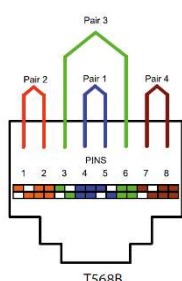

To ensure the transmission performance requirements of the cabling system are maintained, the amount of untwisting shall be kept to a minimum last twist should be no further than 13mm from point of termination. In addition, the stripping back of the outer sheath shall also be limited to the minimum amount required to achieve a successful termination.

Where a rear management bar is provided each cable should be individually secured by way of a cable tie, grouping of cables is deemed to be a poor installation practice.

Patch Panel Capacities

1u 24-way patch panels should be used throughout the installation.

Patch Panel Cable Management

Due to the design of the patch panels there is no requirement for horizontal cable management bars.

User Outlet Specification

All user outlets should meet or exceed the transmission performance requirements for Twisted-Pair Connecting Hardware defined by the standard or the BS EN 50173 Commercial Building Telecommunications Wiring Standard ANSI/EIA/TIA-568B where this standard exceeds BS EN 50173.

Patch panels, outlets, main link should be selected from a single manufacturer's system.

Please contact ICT NID Team to confirm data outlet requirements. **The final numbers will be confirmed by ICT** based on end user requirements and known usage from the group(s) in other areas.

College data outlet requirements are specified in Network Infrastructure Standards main document.

Wall Box & Floor Boxes

All wall/dado boxes & floor boxes are to be sized to allow for the minimum bend radius to be achieved as per the manufacture's guidelines.

Face plates

The user outlet faceplate should meet the following requirements:

- All outlets shall be provided with spring loaded shutters that automatically close when patch leads are removed;
- All IDC connector blocks shall be permanently fixed to the faceplate.
- All unused faceplate apertures shall be provided with blanking plates.
- UPVC plastic to be UV resistant.
- Contrasting colour as per Disability Discrimination Act (DDA) requirements.

User Outlet Terminations

All four pairs of the UTP cable shall be terminated onto the rear of the faceplate via Insulation Displacement Connection (IDC) techniques.

The cables shall be terminated as per the EIA/TIA 568B wiring scheme so that the presentation of the pairs on the RJ45 socket is as follows:

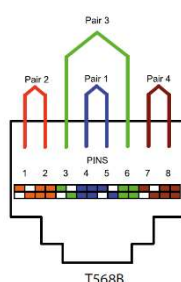

To ensure the transmission performance requirements of the cabling system are maintained, the amount of untwisting shall be kept to a minimum last twist should be no further than 13mm from point of termination. In addition, the stripping back of the outer sheath shall also be limited to the minimum amount required to achieve a successful termination.

Enough slack should remain on the cable to allow the termination to be remade at least twice.

User Outlet & Patch Panel Labelling Scheme

Cabling will be installed and labelled in a logical fashion, as you enter a room cabling ID's will run from left to right in a sequential order. Where there is more than one entrance to a room or area it will be down to the contractor to come up with a logical system that runs in a sequential order.

All outlets should be labelled in accordance with ICT Network Infrastructure Standards:

All bundles will have labelling on all concealment points (i.e. in risers and through holes). This labelling will be done in the following format:

ICT CAT5e/6a (as applicable)
<Installer company name> - <date>
<CWC ID>

All UTP outlets should be labelled in accordance with ICT Network Infrastructure Standards:

AAA/BB/CC

Where:

AAA = The Cabling Wiring Centre (CWC) Number
BB = The patch panel identifier where the first digit identifies cabinet ID and second the panel ID (i.e. AB would be cabinet A panel B)
CC = The outlet reference number (01, 02, 03....24)

Each individual 1U x 24-way Patch Panel should have its own Patch Panel identifier. Upon reaching 'Z', the next panel should be labelled 'AA' then 'AB' etc.

For example, the fourth outlet from Patch Panel 'A' within Wiring Centre 127 in the 1st cabinet would be labelled 127/AA/04 and the fourth outlet from Patch Panel 'C' would be labelled 127/AC/04 etc.

All labelling is to be done with modified acrylic (trifoliate style) laser engraved labels to withstand the passing of time and duration of the CAT 5e/6a warranty (under normal conditions of office use).

All cables will be labelled at patch panel and outlet side for easier identification. This will be placed in the cable sheath and be done as so it won't fall off or smudge but do not require to be as per above requirement.

Patch Cables and Patching

All patching between active data equipment ports, voice services ports, peripheral services ports and terminated outlets should be accomplished using RJ45 patch cords.

The patch cords should be a part of the proposed cabling system and should be included within the cabling systems application and performance warranty.

User patching to form part of the project specification and cost.

These patch cords will be as defined in the ordering information (Appendix E - Ordering)

All patch cables should meet or exceed the transmission performance requirements for Twisted-Pair Connecting Hardware defined by BS EN 50173 or the Commercial Building Telecommunications Wiring Standard ANSI/EIA/TIA-568B where this standard exceeds BS EN 50173.

Different colour patch cables should be used to differentiate between service types:

Data – Blue

VOIP Phones – Blue

Wireless – Red. Wrap around type label, labelled “WAP”

AV – Red. Wrap around type label, labelled “AV”

BEMS - Red. Wrap around type label, labelled “BEMS”

CCTV - Red. Wrap around type label, labelled “CCTV”

Where flood patching is requested (Lecture theatres, labs and others) the patch leads must be labelled at both ends of the lead (labels to be 2x number of patch leads).

Information needs to be provided to ICT’s network infrastructure delivery team and the labels will be provided.

Cable Testing

Following completion of the installation, there are two forms of testing that shall take place:

- *Installation testing* – to be undertaken by the Contractor.
- *Acceptance testing* – to be undertaken by the Contractor but shall be directed and witnessed by NID Team. It should be noted that acceptance testing will involve retesting up to 10% of the entire installation.

Installation Testing

Installation testing should comprise a 100% exhaustive test of the installation by the installation Contractor performed using a calibrated level IIIe tester as a minimum. The testing will be carried out in accordance with the manufacturer’s recommended testing procedures & shall prove the link performance characteristics defined within EN50173. These test results will form part of the 25-year performance warranty offered with the installation.

Acceptance Testing

Upon completion of the installation testing, test results are to be sent to ICT. The test results shall be sent in summary format (PDF) or in the native test format i.e. FLW. This should be a 100% test. We will then use this information to perform 10% witness test on the entire installation.

Test results should not be provided in paper format. The results should be provided in electronic format. It is, however, mandatory that the results are formatted in a data-base type structure on the disc/memory stick that a means of searching for individual results is provided. A printed summary of results should be provided with the completion documentation.

Warranty

The horizontal cabling system shall be designed, supplied, installed, tested and commissioned in strict accordance with manufacturers’ recommendations to achieve a 25-year performance warranty.

Backbone Optical Fibre Installation

Introduction

This Section details the required standards for Fibre Optic cabling. The College has an established policy to install Leviton fibre optic products and has standardised on OS2 fibre type. Due to legacy issues other types may have to be used (only if agreed with ICT). Only the following cable type can be used.

Leviton 24 core 8/125 SM CDT B2Ca This is a mandatory requirement. Further information can be found within appendix E.

Excel 24 core 8/125 SM CST B2Ca This fibre is to be used for external building links. Further information can be found within appendix E.

Corning B2Ca Gel-free Loose Tube Dielectric Armour Indoor/Outdoor Cable This fibre is to be used for external building links where a higher core count is required. Available in 24,48,96 & 144 &192 core counts. Further information can be found within Appendix E.

Installation Requirements

All cable routes should be agreed with ICT's representative prior to commencement of the installation.

All cables shall be either:

- Enclosed in trunking;
- Pulled in duct;
- Securely fastened to tray;

All containment shall be clearly marked at 5 metre intervals and at all concealment points with the following label:

"ICT DATA CABLES"

All cables should be complete between termination points; no cable joints or splices will be permitted unless with specific authorisation of the ICT department in writing.

Holes drilled through walls or floor for the routing of cables shall be suitably sleeved to prevent damage to installed cables.

Labelling

All termination points shall be clearly labelled.

The cable will be labelled with a securely fixed 'traffolyte' type engraved label or with wrapround cable markers, before the fibre panel, showing:

ICT
<Fibre ID> <CWC1 ID> to <CWC2 ID>
<Installer company name> - <date>

Where <Fibre ID> is an College internal ID that will be provided to the installer by ICT. For this to occur the following information needs to be provided:

- <CWC1 ID> ,
- <CWC2 ID> ,

- Number of cores,
- Number of cores terminated,
- Connector type,
- Cable type.
- Any important comments on the installation, if any.

The fibre panel will be labelled with:

<Fibre type> <number of cores> <Fibre ID><CWC ID1><CWC ID2> <X>

Where CWC ID1 and CWC ID2 are the two linked CWCs and CWC ID1 is always the one with the smallest ID value.

X is the panel identifier. Starting with “A” and continuing to “B” and so forth.

Fibre ID. Please contact College ICT NID to obtain the ID number

e.g. To connect CWC42 and CWC1 with OS1 24 cores would be – OS1 24 CWC1 CWC42 A. An additional connection would be - OS1 24 CWC1 CWC42 B

As a safety measure a Laser/LED information sticker will be placed on the front (right hand side) of the fibre tray.

All cables shall be clearly labelled at 5 metre intervals and at all points of entry and exit for concealment, indicating:

ICT
 <Fibre ID> <CWC1 ID> to <CWC2 ID>
 <Installer company name> - <date>

Fibre Optic Termination

All optical fibre cables should be terminated within fibre panels mounted within a CWC’s Cabinet, in accordance with the proposed cabinet layout.

Panels will be mounted in the cabinet such that the connectors are flush with the mounting rails of the cabinet. The front of the patch panel should not be recessed

LC connectors will be used throughout.

All fibre cores shall be spliced and tested.

After testing the contractor should make sure that all dust caps are in place.

To facilitate re-splicing of fibres, sufficient slack cable should be left to enable at least two re-terminations to be achieved. A minimum of 5m service loop should be coiled neatly within the CWC.

Fibre Optic Patch Cords

LC duplex patch cords should be used.

Fibre Optic Testing

Following completion of the installation, there are two forms of testing that shall take place:

- *Installation testing* – to be undertaken by the Contractor.

- *Acceptance testing* – to be undertaken by the Contractor but shall be directed and witnessed by College ICT. It should be noted that acceptance testing will involve retesting up to 10% of the entire installation.

Fibre Optic Installation testing

Installation testing should comprise a 100% exhaustive test of the installation by the installation Contractor. Tier 1 certification must be completed and submitted for each fibre link. Each fibre core shall be tested bi-directionally at 1310 & 1550nm the results combined will be stored electronically. Tier 1 certification refers to the use of a light source and power meter to perform continuity and loss testing of the installed links. The length of the fibre is also measured. We will not accept OTDR test certification. The testing will be carried out in accordance with the manufacturer's recommended testing procedures

Test result will be presented electronically in both the manufacturers format & PDF.

The results form will record:

- The unique identifier of the fibre optic cable and fibre number
- The name of the person conducting the test
- The type and manufacture of the cable being tested
- The date of the test
- The results to be recorded on the form shall be:
- All settings of the test equipment so that the test may be exactly recreated if necessary
- The end of the cable from which the test is carried out
- The measured cable length
- The attenuation at 1310nm and 1550nm (dB) or as appropriate

Acceptance Testing

Upon completion of the installation testing, test results are to be sent to ICT. The test results shall be sent in summary format (PDF) or in the native test format i.e. FLW. This should be a 100% test. We will then use this information to perform 10% witness test on the entire installation.

Warranty

The fibre optic cabling system shall be designed, supplied, installed, tested and commissioned in strict accordance with manufacturers' recommendations to achieve a 25-year performance warranty

Telecommunication fibre services

As part of the critical services to the College we may need to have external services installed to enable the connection of a building or campus to the outside world and/or to the rest of the College network.

These links are done, in most cases, via the installation of fibre cables to the campus and/or building.

Considering the risk to College, especially for the Maintenance teams and Projects that may need to change building fabric where these services would traditionally be installed (risers and cable routes throughout the building) the College will be installing “intake rooms” into the buildings. These will be small secure spaces that will have an ODF (Optical Distribution Frame) installed where the Telco will provide their services to and where their delivery point will be.

The link between that ODF or Intake Room to the main comms room for the building or campus will be done with Imperial College own fibre.

For the design of the space and specification of the ODF please check “Appendix E - Ordering”.

Voice Installation (Copper Backbone Cabling)

Currently College runs a VoIP system and therefore the importance of the voice cabling has been reduced. It is still critical for some services (Life Safety) to run over the voice cabling.

As a rule of thumb there will be a BT demarcation point within each campus. From this location there will be 20 pair installed to the main CWC of each building. The cable will be presented in a DP. (501a voice frame) in the buildings (unless there is a specific requirement to have more).

Internal voice cabling CW1308 (CPR compliant) will then run directly to the equipment where it will terminate either directly into equipment or on an LJU.

There are legacy connections that run over of horizontal cabling but moving forward we are insisting on the connection type above.

Containment

Cablofil Steel Wire Cable Tray or equal conforming to the material and performance of this specification.

Cable basket shall be manufactured from steel wires, welded together and bent into final shape prior to surface treatment.

Surface Treatments:

- Electro zinc plated to EN 12329
- Hot Dipped Galvanised to EN ISO 1461
- Stainless Steel to EN 10088-2 - AISI 316L and EN10088-2 AISI 304L

Steel Wire Cable Tray Widths & Depths

- Cable Tray dimensions are all internal.
- Depths of 30mm, 54mm, 80mm, 105mm & 150mm.
- Widths of 50mm, 100mm, 150mm, 200mm, 300mm, 400mm 450mm,
 - o 500mm & 600mm for depths of 30mm & 54mm.
- Widths of 100mm, 150mm, 200mm, 300mm 400mm & 500mm for
 - o Depths of 105mm & 150mm
- All trays are of 3000mm Nominal long

Specification

Baskets will be manufactured with a longitudinal 'T-welded' safety edge along the top wire of the sidewall (excluding 30x50)

Baskets will be constructed with a 50mm x 100mm mesh configuration.

All fittings (e.g. changes in direction, level and size) shall be constructed on site, to the manufacturer's instructions, using side action bolt croppers and fastened using 25mm and 30mm counter clamps with M6 bolts and nuts, all surface treated as the tray.

Trays will be coupled together using the recommended fixing methods as stated by the manufacturer.

Basket shall be supported at a maximum span of 2.5m by trapeze, wall, floor or channel mounting methods and will not exceed maximum loads as specified by the manufacturer.

All welds will be manufactured to an average minimum tensile strength of 500Kg per weld.

Tests, certification and conformity

Loading and deflection characteristics of the basket should be tested, and the results published in accordance with the European Standard CEI 61537.

Suitability for the support of Cat6a data cabling should be demonstrated by way of independent test verification.

Fire test certification published in accordance with the DIN4102-12 standard to achieve E30 to E90 for temperatures up to 1000oc

Electrical continuity across a coupling should be demonstrated by means of a published test method and result as specified in IEC61537

<https://www.legrand.co.uk/products/cable-management/cablofil/>

http://www.cablofil.co.uk/sites/default/files/Cablofil_low_res_0.pdf

Cables will be protected in their transition out of the containment by being placed into flexi-duct or cable waterfall.

In areas, for aesthetic/architectural reasons, if there is need for black containment the Cablofil 54 EZ+ cable basket can be used. This is also used in harsh environments

<http://www.cablofil.biz/product/standard-cable-trays/cf-54-ez>

Please see “Appendix E – Ordering” for more information.

Mechanical Protection

Holes drilled through walls or floors for the routing of cables shall be suitably sleeved to prevent damage to installed cables. Where cables pass through floors such protection shall be extended to at least skirting height.

Waterfall systems and others are to be used on exit of the basket into cabinets and appropriate supports used for any flexible ducting used to link any main cable runs to rooms.

Electrical Protection

Notwithstanding the compliance to BS6701 and the issues of cable segregation, additional care should be taken to ensure cables are not routed adjacent to other services where electromagnetic emissions may be generated. Cables should have at least 300mm air gap/separation to any main electrical distribution.

Electromagnetic Compatibility

All cabling components should have been successfully tested for EMC compliance as specified in the European EC Directive 89/336/EEC as amended by Directive 92/31/EEC.

Completion Documentation

The installation Contractor should, on completion of their works and prior to acceptance by ICT, submit two copies of all records and schematics for the installation.

Schematics will detail all cable runs and termination points. The installed cable capacity, cable identification reference, length and type of cable shall be identified.

Records will show clearly all cable terminations and cross connections together with cable capacity and installed length.

The following documentation is required:

- Cabling schematics
- As fitted drawings
- Test results
- Cabinet Layouts
- All relevant operating and maintenance manuals
- All documentation and drawings will be required in electronic format. Full details of CAD formats will be provided. All drawings shall be “as fitted” and shall take account of all changes and variations.

Drawings

All drawings should be provided in accordance with College’s AutoCAD strategy, in digital format.

Please refer to Support Services Engineering Team CAD Strategy (Estates Department).

Appendix D

External Infrastructure Specification and Installation

Introduction

This section details the required standards for External Infrastructure.

All buried ducting infrastructure shall be installed in strict accordance with NJUG National Joint Utilities Group guidelines and the College Estates specification.

This document will establish the requirements for the construction and installation of:

- Ducting
- Manholes and inspection pits
- Routes
- Duct Entry & Sealing
- Labelling
- Approved pre-formed chamber systems
- Installation & commissioning
- Using the infrastructure
- Maintenance and Business As Usual (BAU)

Ducting

The construction and installation of ducts will be as per the design drawings and must adhere to manufacturer's instructions and specifications.

All runs should be laid as straight as possible. If needed, you can carefully bend the ducts or use pre-formed bends.

The ducts must be laid and bedded in such a way as to prevent damage from rocks etc. within the trench or in the back-filling material.

All ducts must be provided with a nylon draw rope.

Duct will be purple in colour.

Where the duct enters the chamber, the duct shall enter flush with the wall.

Duct must not enter through corners and be no less than 75mm from the side wall.

Duct to enter wall 600 mm minimum depths from top of frame.

Duct to clear of base by 100mm minimum.

Ducts will enter the inspection pits using duct glands or have the holes pre-installed if using the pre-formed manhole manufacturer.

The ducts will be sized in collaboration with network infrastructure delivery & estates teams. They will be sized to enable all services required on day one and to accommodate future strategy of the campus and buildings.

Manholes & Inspection pit

The construction and installation of manholes will be as per manufacturer's instructions and estates specifications, we will need to enable College and or third parties to effectively use them. This means that there needs to be available;

- Step irons.
- Cable routing/bearers.
- Bell mouths.
- Sump.
- Anchor iron.
- Cable glands on all ducts (or similar).

The sizing will be calculated depending on the number of ducts required for the run. And the above specifications can be reduced if the manhole/inspection pit is small enough not to necessitate parts of the requirement (for example: steps will not be needed if there is no way to get inside of the manhole.

Manhole covers and construction must be fully adequate to the environment they will be in. Meaning that the construction and the cover of a manhole in a footpath will have a different specification and construction from the ones in the highway or a road or access for heavy equipment.

All manhole covers will reflect their ownership/use.

ID A: "ICL ICT"

For all manhole covers that are dedicated to ICT cabling.

ID B: "ICL ICT/BT"

For all BT specified ducts and routes but owned by College.

All manholes will be geotagged information to be sent in electronic format as part of the handover documentation.

Routes

The construction and installation of ducting & manholes will be as per manufacturer's instructions and must comply with NJUG National Joint Utilities Group guidelines and the College Estates specification.

All buildings will have full resilient routes and dual entrance points as a minimum. The penetration of the ducts into the building will be into an intake room and the ducts must be adequately sealed.

All campuses will have multiple and resilient routes and dual entry points as a minimum. Four, at least, are advisable as the connectivity to the campus is done via third parties (Telco's) which may be limited in the area where they can enter the campus.

Duct Sealing

All building entry points shall be sealed with gas tight / vermin resistant proprietary seals.

BT Chambers and ducts

BT chamber and duct specifications are excluded from these standards. BT External infrastructure install to follow most current BT specifications for manholes and ducting.

BT routes are to be designed and maintained by College, manhole covers will carry chamber ID according to College standard and as described above.

Cable labelling

Fibre cabling will be labelled with information required by the company providing the service to Imperial or third parties working within our estate.

It will be done in a labelling system that will withstand the harsh conditions of the external installation. The label needs to be attached and readable at any time during the lifetime of the cable and the responsibility to maintain so will be of the Telco or owner of the fibre.

The Imperial College own installations will follow the same rules as all others and the information to be included in the labels is as described in the cable installation standards appendix C.

Accepted pre-formed chamber systems

Cubis

<http://www.cubis-systems.com/uk/>



Cubis can provide the chambers with pre-fitted accessories and duct entry making it easier to install onsite. This is an option but can also be done and assembled onsite.



Detailed information:

<http://www.cubis-systems.com/uk/products/large-chambers/ultima-connect/#main>

<http://www.cubis-systems.com/media/3335/stakkabox-ultima-connect-brochure.pdf>

<http://www.cubis-systems.com/media/3065/cubis-product-size-guide.pdf>

Examples:

<https://youtu.be/BluVGrkuMig>

<https://youtu.be/yLc06JRIOmo>

Clark

<http://www.clark-drain.com>

Detailed information:

<http://www.clark-drain.com/products/>

<http://www.clark-drain.com/products/chamber-access-solutions/>



Manufactured duct entries.

Accessories to be installed with an agreed pre-configuration and with duct entries made by manufacturer.

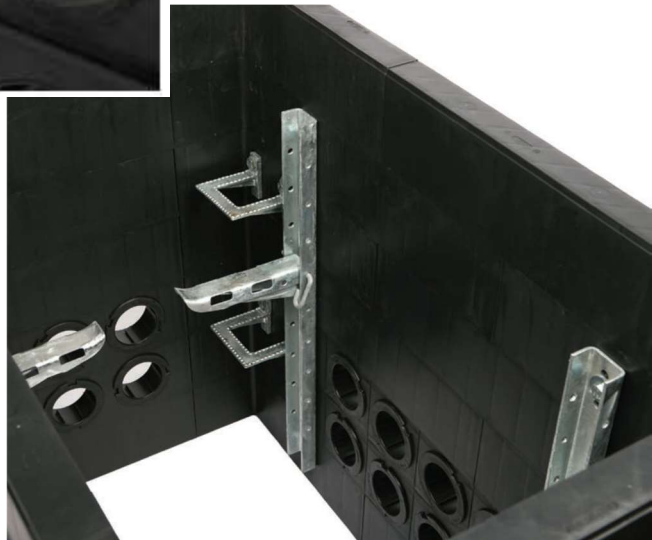

Construction and installation example.



All manufacturer specifications are to be followed on any, or all, of the systems. Both systems have comprehensive literature to enable an easy installation (which includes videos) and adequate to different types of requirement and location of installation.

Installation commissioning and use

ICT NID team will check the installation and pre-delivery of any such systems to ensure an adequate installation and the creation of the documentation needed to manage the infrastructure.

Any cost of associated with the commissioning will be passed on to the organisations that require the services to be installed.

New installations requests and wayleave

All service requests for installing new fibre optic cabling by telecommunications service providers shall be passed to ICT Network Infrastructure Delivery Team ictns-infra-dl@imperial.ac.uk for consideration and approval. Installation

ICT Network Infrastructure Delivery Team will liaise with Legal Services to agree on the acceptance of wayleave.

New installations are Permit to Work activity and RAMS are required to be submitted and approved prior to commencement of work by ICT and College Estates department.

Maintenance and Business As Usual (BAU)

Supervision and installation of the external ICT infrastructure is responsibility of the ICT.

Repair to any damage to the external infrastructure is responsibility of College Estates department.

Drawings

Please refer to Support Services Engineering Team CAD Strategy.

In addition to this all chambers to be geo tagged and the information included into the drawings to be delivered to ICL.

Appendix E Ordering

Please contact your suppliers for up-to-date information.

It will be the responsibility of the data installer to supply all passive elements of the network infrastructure.

Components cannot be mix & match from Excel and Leviton as this will void the warranty of each respective system.

Please contact NID for clarification ictns-infra-dl@imperial.ac.uk

Passive equipment - Copper

CAT5e U-UTP B2ca Cabling

Only to be installed in circumstances where a compliant CAT6a solution cannot be achieved. (please contact NID Team for clarification)

Brand	
Excel	
Designation	Part code
EXL C5E 4PR UTP VT X 305M B2CA	190-066
Ethernet Category: Cat5E Outer sheath colour: Violet Overall screening: None Conductor screening: None Reaction-to-fire class according to EN 13501-6: B2ca Smoke development class according to EN 13501-6: s1a Flaming droplets/particles according to EN 13501-6: d1 Euro class acidity according to EN 13501-6: a1 Outside Diameter 5.1 mm Min Bend Radius (Installation) 8 x outside diameter Min Bend Radius (Operational) 4 x Outside diameter	
Packaging	
305m Fast feed box	

CAT5e Components

Brand	
Excel	
Designation	
<u>EXCEL CATEGORY 5E OFFICE UNSCREENED MODULE - LOW PROFILE - WHITE</u>	Part code <u>100-275</u>
NB: Also available in grey to comply with Equality Act 2010 & Part M of building regulations where required.	
Packaging	
Single unit	
	

Brand	
Excel	
Designation	
<u>EXCEL CATEGORY 5E UNSCREENED MODULE LOW PROFILE - 6C RJ45 - WHITE</u>	Part code 100-757
NB: For use in floor boxes	
Packaging	
Single unit	
	

Brand	
Excel	
Designation	Part code
<u>Excel Office Single Gang Faceplate Complete with 2 Half Blanks - Office White</u>	100-270
<u>Excel Office Double Gang Faceplate Complete with 2 Half Blanks - Office White</u>	100-271
NB: Also available in grey to comply with Equality Act 2010 & Part M of building regulations where required.	
Packaging	
Single unit	
	

Brand	
Excel	
Designation	Part code
<u>Excel 24-port Angled Unloaded 1U (UTP/FTP) Keystone frame - Black</u>	100-023
NB:	
Packaging	
Single unit	
	

Brand	
Excel	
Designation	Part code
<u>Excel Category 6 (UTP) Butterfly Style Toolless Angled Jack - Black</u>	100-213
NB: CAT6 UTP angled modules to be used in lieu of CAT5e as no CAT5e angled module available at this present time. These are to be used with 24 port angled panel part no. 100-023	
Packaging	
Single unit	
	

CAT6a U-FTP Cca Cabling

College preferred cabling system, all new buildings & projects will be installed with this cabling type, unless otherwise stated by College NID Team.

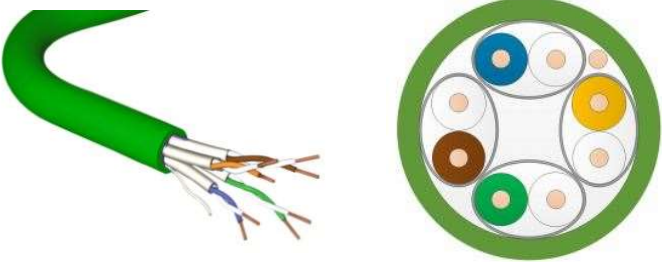
Brand	
Leviton	
Designation	Part code
Category 6A U/FTP EuroClass Cca Cable	AC6U/FTP-CCA-305GN
<p>Ethernet Category: Cat6a</p> <p>Outer sheath colour: Green</p> <p>Overall screening: None</p> <p>Conductor screening: Individually screened</p> <p>Reaction-to-fire class according to EN 13501-6: Cca S1a D1 a1</p> <p>Smoke development class according to EN 61034 Pass</p> <p>Flaming droplets/particles according to EN 60332-1-2 Pass</p> <p>Euro class acidity according to EN 60754 Pass</p> <p>Outside Diameter 6.7mm</p> <p>Min Bend Radius (Installation) 8 x outside diameter</p> <p>Min Bend Radius (Operational) 4 x Outside diameter</p>	
Packaging	
305m reel box or 500m cable reel	
	

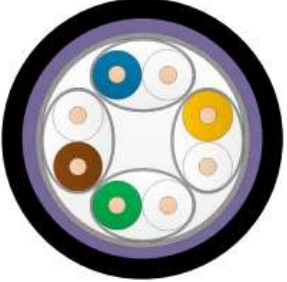
Brand	
Leviton	
Designation	Part code
Category 7 S/FTP External cable	UM10-HF1-X
Note: To be used in all external locations where cabling will be not be in a protected environment. Please note external grade cabling can only be brought into the building 2m.	
<p>Ethernet Category: Cat7</p> <p>Outer sheath colour: Black</p> <p>Overall screening: Braided screened</p> <p>Conductor screening: Individually screened</p> <p>Reaction-to-fire class according to EN 13501-6: N/A External Only</p> <p>Smoke development class according to EN 61034 N/A</p> <p>Flaming droplets/particles according to EN 60332-1-2 N/A</p> <p>Euro class acidity according to EN 60754 N/A</p> <p>Outside Diameter 8.2mm</p> <p>Min Bend Radius (Installation) 8 x outside diameter</p> <p>Min Bend Radius (Operational) 4 x Outside diameter</p>	
Packaging	
500m reel	
	

Brand	
Leviton	
Designation	Part code
10GPlus Cat 6A Shielded Tool-Free Snap-In Jack	AC6JAKS000DC
Packaging	
Single unit	
	

Brand	
Leviton	
Designation	Part code
<u>24 Port 1U V12 Angled Snap-In-Jack Panel</u>	MMCPNLX24SIJ2MAN
NB:	
Packaging	
Single unit	
	

Brand	
Leviton	
Designation	
Part code	
1 gang 86 x 86mm Single Gang Faceplate, White	MMCWDOUNI030
2 gang 86 x 147mm Double Gang Faceplate, White	MMCWDOUNI031
Note: To comply with with Equality Act 2010 & Part M of building regulations contrasting inserts need to be installed when using Leviton faceplates.	
Packaging	
Single unit	
	

Brand	
Leviton	
Designation	
Part code	
Angled shutter 25 x 50 mm Angled Faceplate Module	MMCANG0623
NB:	
Packaging	
Single unit	
	

Brand	
Leviton	
Designation	Part code
6C 25 x 38 mm Shuttered Module – Floor Box / GOP Box Shutter	MMCWDO06C001
Packaging	
Single unit	
	

Brand	
Leviton	
Designation	Part code
<u>Cat 6A Universal Tool-Free RJ45 Connector.</u>	6APLG-S6A
Packaging	
Single unit	
	

Passive equipment – Fibre

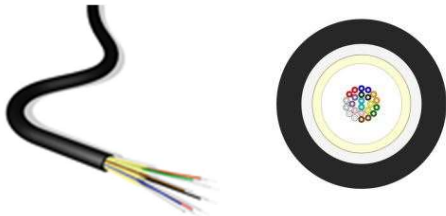
Brand	
Leviton	
Designation	Part code
Optical Central Dry Tube B2CA Cable	GF-108-CDT24-LU-B2ca
<p>Outer sheath colour: Black</p> <p>Reaction-to-fire class according to EN 13501-6: B2ca S1a D1 a1</p> <p>Smoke development class according to EN 50399 Pass</p> <p>Flaming droplets/particles according to EN 50399 Pass</p> <p>Euro class acidity according to EN 50267 2-3 Pass</p> <p>Outside Diameter 7.0mm</p> <p>Tube Diameter 3.5m</p> <p>Min Bend Radius (Installation) 20 x outside diameter</p> <p>Min Bend Radius (Operational) 15 x Outside diameter</p>	
Note: To be used on internal applications.	
Packaging	
Reel cut to length / 2km /4km drum	
	

Brand	
Excel	
Designation	Part code
Enbeam OS2 Singlemode 9/125 24 Core Armoured CST Fibre Optic Cable Loose Tube B2ca - Blue	295-309
<p>Outer sheath colour: Blue</p> <p>Reaction-to-fire class according to EN 13501-6: B2ca S1a D0 a1</p> <p>Smoke development class according to EN 50399 Pass</p> <p>Flaming droplets/particles according to EN 50399 Pass</p> <p>Euro class acidity according to EN 50267 2-3 Pass</p> <p>Outside Diameter 9.5mm (+/- 0.5mm)</p> <p>Tube Diameter 3.2mm (+/- 0.3mm)</p> <p>Min Bend Radius (Installation) 20 x outside diameter</p> <p>Min Bend Radius (Operational) 10 x Outside diameter</p>	
Note: To be used on all external applications.	
Packaging	
Reel cut to length - drum	
	

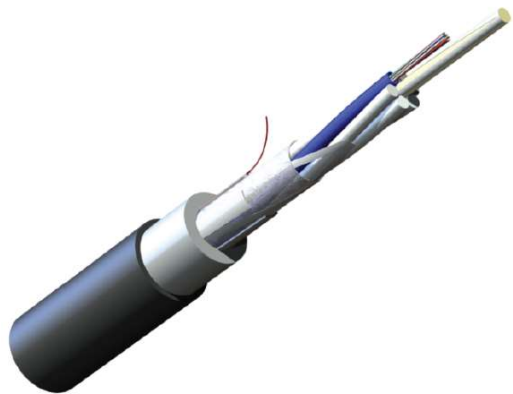
Brand	
Corning	
Designation	Part code
FREEDM™ B2 Gel-free Loose Tube Dielectric Armour Indoor/Outdoor Cable	Dependant on core count
<p>Outer sheath colour: Black</p> <p>Reaction-to-fire class according to EN 13501-6: B2ca S1a D1 a1</p> <p>Smoke development class according to EN 50399 Pass</p> <p>Flaming droplets/particles according to EN 50399 Pass</p> <p>Euro class acidity according to EN 50267 2-3 Pass</p> <p>Outside Diameter 13.9mm (Based on 96c fibre count)</p> <p>Tube Diameter 3.0mm (12c per tube)</p> <p>Min Bend Radius (Installation) 278mm based on 96c</p> <p>Min Bend Radius (Operational) 209mm based on 96c</p>	
Note: To be used on all external applications.	
Packaging	
Reel cut to length - drum	
	

Brand	
Leviton	
Designation	
LC Duplex Singlemode – 24-way (12 Duplex)	FPCC1SXSM24LC2
LC Duplex Singlemode – 48-way (24 Duplex)	FPCC1SXSM48LC2
Note: 24-way the preferred option, as allows us to split the diversly routed fibres over 2 cabinets when there are 2 cabinets installed	
Packaging	
Single unit	

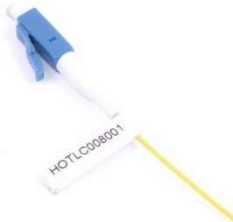

Brand	
Leviton	
Designation	
LC SM 8/125 Pigtail	HOTLC008001
Packaging	
Single unit	
	

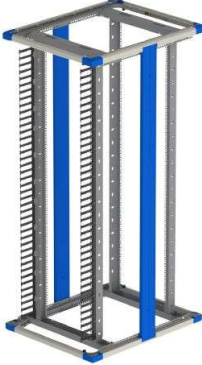

Cabinets

Brand	
EFS	
<p>Note: 42U 800x1000 to be used in all situations unless it is to marry up with an existing cabinet that is 800d.</p>	
Designation	Part code
<p>Access rack</p> 	<p>42U 800x875 - ACP0000237</p> <p>42U 800x1000 ACP0000340</p>
<p>Part Number:</p> <p>ACCESS with the following configuration: Rack Height 42/47 Unit Rack Width 800 Wide Rack Depth 875/1000 Deep Base Options Jacking Feet & Castors - (H) Rail Type 19" Rails (2 Pairs - RCM front - STD rear) - Front Rails STD - 128mm from front face (RCM Fingers will protrude front frame) - Rear Rails - 70mm from rear face Front Door No Door Rear Door No Door Side Panels No Side Panels Top Panel Front Option No Panel Top Panel Middle Option No Panel Top Panel Rear Option No Panel</p> <p>40 x TLCMS and 40 X TLCMEF fitted front only - evenly distributed RCM Fingers fitted front only Supply with BTK loose 1 x Earth Kit 2 x ABS4230 Fitted each side, fitted to offset rear (front edge in line with centre extrusions) 2 Pair Unit Height Labels (Bottom to Top) - Fit front/Rear</p> <p>Rack Colour Grey with Blue Trim</p>	

Brand	
Excel	
Designation	Part code
Excel Switched - 12 Way 45° Angle UK Socket PDU - Master Switch - 16A IEC 60309 Plug - Vertical	D16-12-EXL
NB:	
Packaging	
Single unit	
	

Brand	
Hellermann Tyton /CMS	
Designation	Part code
5 Ring (Plastic) Cable Management bar	CTB05PRB
NB:	
Packaging	
Single unit	
	

Brand	
Corning	
Designation	Part code
<p>Optical Distribution Frame (ODF) – Centrix</p> <p>Centrix™ Front Access Cabinet, H2200 x W900 x D300, right cable entry, walls, door with acrylic glass window, bottom channel function, assembled</p>	<p>CTX-FA-CAB-2209PGRAB</p>
<div data-bbox="252 741 466 775">Centrix™ System</div> <div data-bbox="820 730 963 871" style="text-align: right;">  </div> <div data-bbox="252 898 331 920">Cabinets</div> <div data-bbox="252 936 435 958">Ordering Information</div> <div data-bbox="252 972 960 1066" style="border: 1px solid black; padding: 5px; margin: 10px 0;"> <p>CTX - FA - <input type="text"/> <input type="text"/> <input type="text"/> <input type="text"/> <input type="text"/> <input type="text"/> 0 9 <input type="text"/> <input type="text"/> <input type="text"/> <input type="text"/> <input type="text"/> <input type="text"/></p> <p style="text-align: center;"> 1 2 3 4 5 6 7 </p> </div> <div data-bbox="272 1070 478 1305"> <p>1 Select cabinet configuration. CAB- = Single Cabinet CAB2 = Dual Cabinet (option „M“ in point 5)</p> <p>2 Select frame height. 18 = 1800 mm 20 = 2000 mm 22 = 2200 mm</p> <p>3 Select walls. N = No side walls, no rear wall S = With side walls, no rear wall P = With side walls and rear wall</p> </div> <div data-bbox="496 1070 722 1346"> <p>4 Select doors. N = No doors G = Doors with plexiglass window, with lock M = Doors, full metal, with lock</p> <p>5 Select patchcord management system / incoming cable L = Patchcord management system on the left (feeder cable on the right side) R = Patchcord management system on the right (feeder cable on the left side) M = Patchcord management system in the middle (for dual cabinet only)</p> </div> <div data-bbox="740 1070 951 1218"> <p>6 Select cabinet preinstallation. A = Assembled cabinet N = Non-assembled cabinet (flat pack)</p> <p>7 Select bottom channel option. B = Bottom channel preinstalled N = No bottom channel (closed bottom area)</p> </div>	
<p>NB: Any other necessary products please contact ICT. These are to be installed in every Intake Room and Main Comms room. Also note that it will be important to check which side the cable entry will be from if more than one is to be installed and depending on fibre entry point.</p>	
	

http://csmedia.corning.com/opcomm/Resource_Documents/spec_sheets_rl/foh/CTX-CAB-F2209PGRAB_EMEA_BEN.pdf	
Accessories	
<p>Spliced Fibre</p> <p>Centrix™ Unit, 4U, 12 Cassettes each with 24 LC UPC adapters & SM pigtails, 250 µm standard SM pigtails, total of 288 F</p>  <p>http://catalog.corning.com/opcomm/en-GB/catalog/ProductDetails.aspx?cid=centrix_hardware_web&pid=122941&vid=122946&rot=</p>	<p>CX4U8P24-A9-2RH000</p>
<p>Fibre lead</p> <p>EDGE™ Solutions Low-loss Patchcord, LC duplex uniboot connectors, SMF-28® Ultra OS2, standard reverse fibre polarity, LSZH/FRNC jacket, yellow, 4 m</p> <p>Note: for inter-ODF cabinet connection get the 7m patch lead, for single ODF cabinet connection get the 4m patch lead and for the distribution and router cabinet(s). The number highlighted in red denotes length</p>  <p>http://csmedia.corning.com/opcomm/Resource_Documents/spec_sheets_rl/fo_cab/E787802GNZ20004M_CALA_AEN.pdf</p>	<p>E787802GNZ20004M</p>

MTP to LC Presentation

Centrix™ standard access 4RU mounted HSG empty
Centrix™ Mod 24 LC/UPC-2MTP PRT FRNT RGT (each has 2 MTP
connectors and 12 duplex LC)



<http://catalog.corning.com/opcomm/en-GB/catalog/ProductDetails.aspx?pid=122915&vid=122916&cid=&productid=122915>

<http://catalog.corning.com/opcomm/en-GB/catalog/ProductDetails.aspx?pid=143255&vid=143259&cid=&productid=143255>

CTX-S4U

CTX24A9-892RRR

MTP Presentation

EDGE™ Housing, 1 rack unit, holds up to 12 EDGE modules or
panels

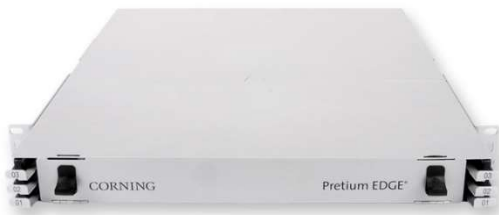

http://catalog.corning.com/opcomm/en-GB/catalog/ProductDetails.aspx?cid=edge_housings_web&pid=130469&vid=130486&rot=

EDGE-01U-SP,

EDGE™ AO Panel, 72 F, Single-mode (OS2)

EDGE-CP72-U1,



http://catalog.corning.com/opcomm/en-GB/catalog/ProductDetails.aspx?cid=edge_panels_web&pid=131348&vid=120048&rot=

EDGE™ Module, 12 F, LC Duplex to MTP® Connector, Bend-improved Single-mode (OS2)

ECM-UM12-04-89G



http://catalog.corning.com/opcomm/en-GB/catalog/ProductDetails.aspx?cid=edge_modules_web&pid=33065&vid=33271&rot=

MTP Trunks

G9090**144**GLZ88U**010**M

EDGE™ Solutions Trunk Cable, SMF-28® Ultra OS2, MTP® to MTP®, **144** fibres

Note: Check fibre core requirements prior to purchasing. The numbers highlighted in red denote fibre core numbers and length



MTP Harness

H897812GLZ-4A1.65M

EDGE™ Solutions Harness, SMF-28® Ultra OS2, 12 fibres, MTP® to 6 LC Duplex Uniboot Connectors, Universal LC 150mm stagger, 1.65 m

Note: Check stagger and length prior to purchasing.



CTX Module

Centrix™ 24 Port LC/UPC MTP® module.

Note: The letter highlighted in red denotes left or right handed.



CTX24A9-892**RU**
CTX24A9-892**LU**

Accessories

Fibre Optic Cleaning Tool used to clean MTP® connector end faces as well as MTP Connectors installed in a module

2104466-01

 <p>http://catalog.corning.com/opcomm/en-GB/catalog/ProductDetails.aspx?cid=edge_accessories_web&pid=29909&vid=110987&rot=</p>	
<p>NOTE: Please bear in mind that some of the products have no part code as they depend on length and number of fibre cores and hence need to be ordered to fit the design. Unfortunately, we cannot provide a “one size fits all” information in this document for these products. Please contact ICT if necessary.</p>	

Fire stopping (Cable Transit Pathways)

Brand	
Legrand Cablofil	
Designation	Part code
EZ-Path Fire Transit Pathways	
	EZD44 EZ Path Max - CM250058
Note: You will need to order wall / floor plates to suit the application.	
Ordering	
sales@cabcon.co.uk	

Patch cords



Brand	
Assynia	
Designation	Part code
CAT5e	
Booted CAT5e patch cable (0.5m) – all colours	FB5E-005
Booted CAT5e patch cable (1.0m) – all colours	FB5E-010
Booted CAT5e patch cable (1.5m) – all colours	FB5E-015
Booted CAT5e patch cable (2.0m) – all colours	FB5E-020
Booted CAT5e patch cable (3.0m) – all colours	FB5E-030
Booted CAT5e patch cable (4.0m) – grey only	FB5E-040GY
Booted CAT5e patch cable (5.0m) – all colours	FB5E-050
Booted CAT5e patch cable (6.0m) – grey only	FB5E-060GY
Booted CAT5e patch cable (7.0m) – all colours	FB5E-070
Booted CAT5e patch cable (10.0m) – all colours	FB5E-0100
Booted CAT5e patch cable (15.0m) – grey only	FB5E-0150GY
Ordering	
CMS (http://www.cmsplc.com/)	
	

Brand	
Excel	
Designation	Part code
CAT6A	
Booted CAT6a patch cable (1.0m) – blue	100-159
Booted CAT6a patch cable (1.5m) – blue	101-141
Booted CAT6a patch cable (2.0m) – blue	100-157
Booted CAT6a patch cable (3.0m) – blue	100-158
Booted CAT6a patch cable (1.0m) – red	100-161
Booted CAT6a patch cable (1.5m) – red	101-142
Booted CAT6a patch cable (2.0m) – red	100-162

Booted CAT6a patch cable (3.0m) – red	100-163
Ordering	
paul.collins@mayflex.com	

Containment

Brand	
Cablofil or Equivalent	
Designation	Part code
Cablofil steel wire cable tray or	
There are too many options available. These will need to address specific job/project requirements.	
Ordering	
	
https://www.legrand.co.uk/products/cable-management/cablofil/	
http://www.cablofil.co.uk/sites/default/files/Cablofil_low_res_0.pdf	
https://www.legrand.co.uk/media/4564/cablofil_steel_wire_cable_tray.pdf	(all product guide – Use part code search to find product)
Accessories:	
DEV100GS Cable Dropout Plate	CM585160

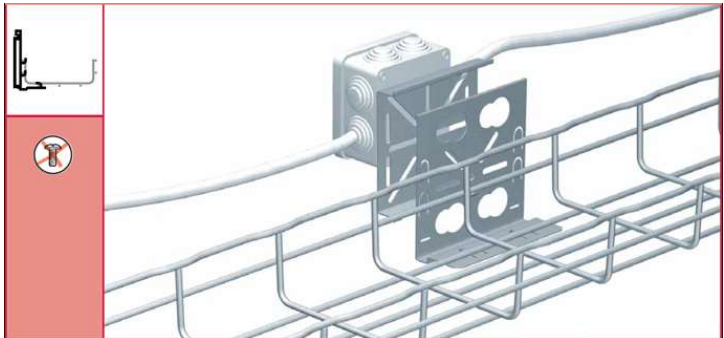
	
<p>CLIPN Black Identification Tag Pack: 1 pk of 50 *</p>  <p>* Please note that there are packs with more quantities</p>	<p>CM559127</p>
<p>Cable Exit</p> 	<p>CM350535</p>
<p>Conduit Clamp Kit (Bottom and side installation)</p> 	<p>CM585410</p>

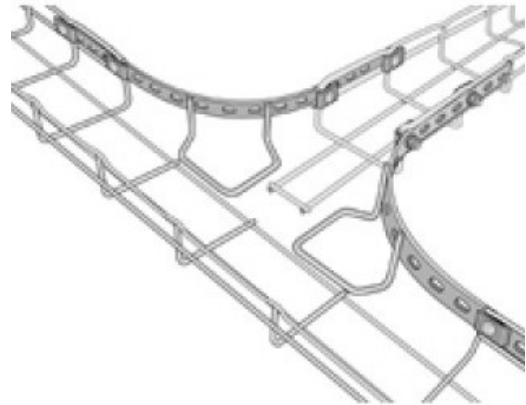
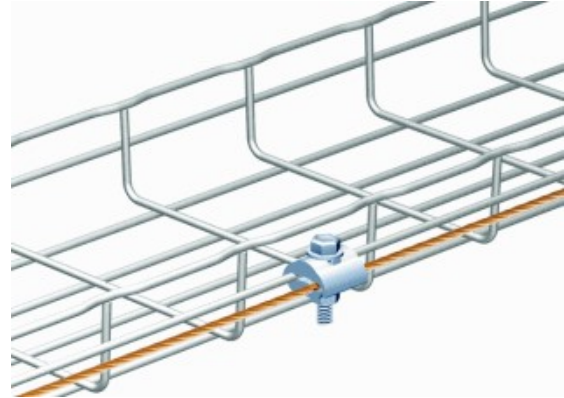
		
<p>RADT90 Radius Shield</p> 		<p>CM840101 CM840111 CM840131</p> <p>CM840103 CM840113 CM840133</p>
<p>GRIFE QUIP</p> 		<p>CM585327</p>
<p>Elevation Change Hinge</p>		<p>Parts Required: 2x CM558403 8x CM801011 4x CM558011</p>

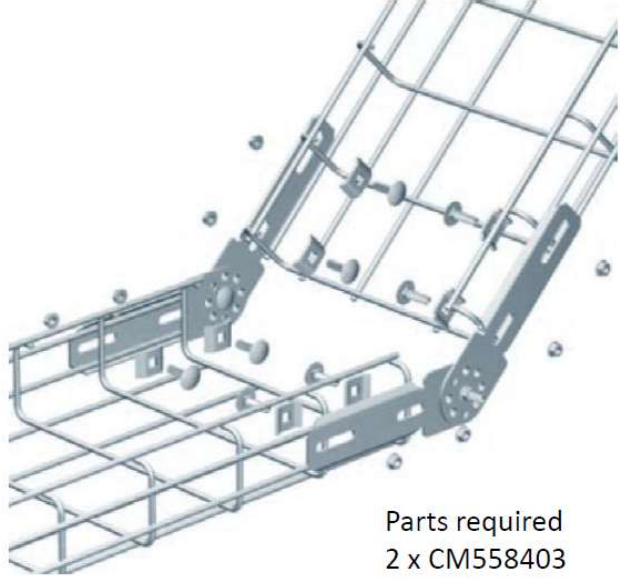
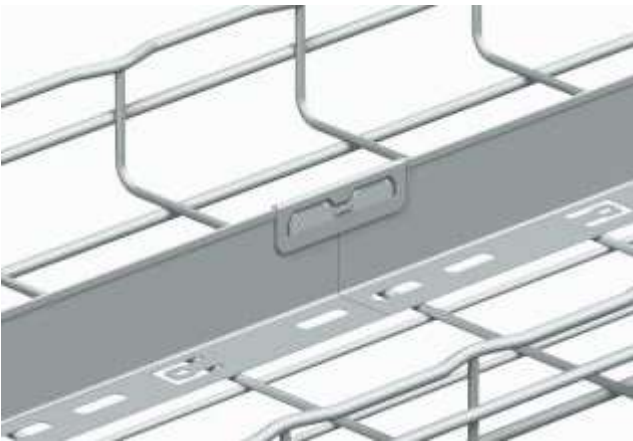
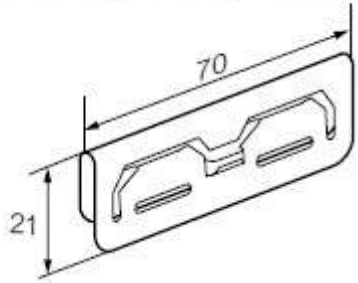
 <p>Parts required 2 x CM558403 8 x CM801011 4 x CM558011</p>	
<p>Divider Strip</p> 	<p>COT</p> <p>CM923010 CM923020 CM923030 CM923040</p> <p>CM923013 CM923023 CM923033 CM923043</p> <p>CM923014 CM923024 CM923044</p>
<p>Divider Coupler</p> <p>⬆️⬆️ 30 → 105 mm ⬅️⬅️ 100 → 600 mm</p> 	<p>COT J</p> <p>CM923050 CM923054</p>
<p>Tray Reduction Kit</p>	<p>EDRSKIT</p> <p>Parts required 1 x CM558211 4 x CM801011 4 x CM558011</p>

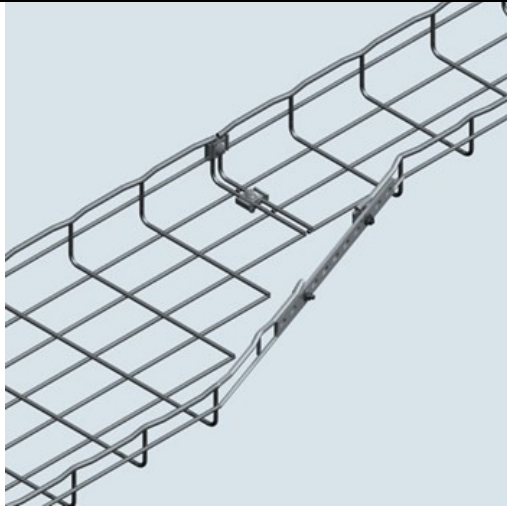

2 x CM558041

<https://www.legrand.us/cablofil/cable-tray-wire-mesh/splicing/edrskit.aspx>

<https://www.legrand.us/-/media/brands/cablofil/cablofil-products/cable-tray-wire-mesh/cutsheets/edrskit%20cutsheet.ashx>

Conduit and box support

CM50 / CM50 XL / CAT40



CM 50 (mm)		CM 50	 100	 586 060	 586 063	 586 068	 586 064
CM 50XL (mm)		CM 50XL	 100	 586 130	 586 133	 586 138	 586 134
CAT 40 (mm)		CAT 40	 20	 586 190	 586 197	 -	 586 194

<http://www.cablofil.co.uk/product/box-conduit/cm50-cm50-xl-cat40>

Angle Bracket

Parts required:

- 1 x CM557300
- 2 x CM801011
- 2 x CM558011
- 2 x CM558041

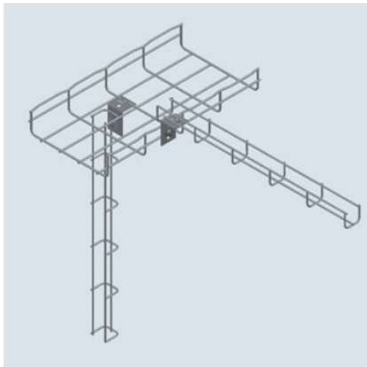
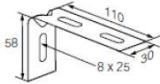
		<p>1 x CM557300 2 x CM801011 2 x CM558011 2 x CM558041</p>	
<p>US Products available to COLLEGE installers (or replacement):</p>			
<p>DO Waterfall Dropout</p> <p>(https://www.legrand.us/cablofil/cable-tray-wire-mesh/other-mounting/do/)</p> <p>(https://www.legrand.us/-/media/brands/cablofil/cablofil-products/cable-tray-wire-mesh/cutsheets/do%20cutsheet.ashx)</p>	<p>DO54/150 DO54/300 DO105/150 DO105/300</p>		
<p>Over-the-top dropout</p> <p>https://www.legrand.us/cablofil/cable-tray-wire-mesh/other-mounting/otdofas.aspx</p> <p>https://www.legrand.us/-/media/brands/cablofil/resources/cut-sheet/cabcs0706%20-%20mini%20waterfall.ashx</p>	<p>OTDOFAS</p>		
<p>Universal Drop Out</p> <p>https://www.legrand.us/cablofil/cable-tray-wire-mesh/other-mounting/udo.aspx</p> <p>https://www.legrand.us/-/media/brands/cablofil/resources/cut-sheet/cf-cutsheet-universal-drop-out.ashx</p>	<p>UDO</p>		
<p>Cable Bundler (Optional to Velcro)</p> <p>https://www.legrand.us/cablofil/cable-tray-wire-mesh/other-mounting/cablo-snap.aspx</p> <p>https://www.legrand.us/-/media/brands/cablofil/cablofil-products/cable-tray-wire-mesh/cable-management-accessories/cable-bundler/cablosnap/cabcs1018-cablo-snappdf.ashx</p>	<p>CABLO SNAP</p>		

Brand	
Erico or Equivalent	
Designation	Part code
J-Hooks	
Ordering	
CMS (http://www.cmsplc.com/)	
	
CADDY CAT HP - (J-Hooks) 100mm	HPJ100

Brand	
Viking or Equivalent	
Designation	Part code
A4 Document wallet	W230
Ordering	
https://www.viking-direct.co.uk/en/p/W230	
	

Brand	
Veracity –	
Note: To be used where extended distances are required externally for CCTV. Maximum distance 200m. Contact NID Team for further information.	
Designation	Part code
Outreach MaxXT	VOR-ORM-XT
Ordering	
	

Active equipment

WAPs

Brand	
Cisco	
Designation	Part code
College ICT will specify the units and design the implementation.	
Ordering	
Imperial College London – ICT	

Switches

Brand	
Juniper	
Designation	Part code
College ICT will specify the units.	
Ordering	
Imperial College London - ICT	
	

Appendix F Contractor Responsibility Matrix

Project Responsibilities	ICL NID Team	Main Contractor	M&E Contractor	Data Contractor
CWC				
CWC Construction (Walls Doors & Windows)				
Anti Static Flooring				
Supply and installation of EZ Path(s) units				
Holes for EZ path(s)				
16a Commando Sockets (2 per cabinet)				
63a Commando Socket (Router Location only)				
13a Cleaners socket				
Earth Bar				
Data Containment - 600mm minimum				
Aperio Lock - ICT override barrel				
A/C (where applicable)				
Fire Detector / Optical Smoke Detector				
Lighting (Inc Emergency lighting)				
Supply & Installation College Spec Cabinet(s)				
2no PDU's per cabinet (12 way)				
Earthing of cabinet(s) to earth bar				
Cabinet CWC label(s) "CWCXXX"				
Patch Panel(s)				
Patch panel labelling inc wrap around labels				
Patch panel earthing				
Cable management bars (including for Switches)				
Fibre optic cabling (where applicable)				
Containment for fibre optic cabling				
Builders works for fibre optic cabling				
Supply of switches				
Installation of switches				
Supply of WAPs				
Installation of WAPs				
Supply of patching schedule				
Supply of patch leads				
Patching at CWC				
J hooks - 4no per CWC				
A4 Document Wallet - 1no per CWC				
Digital photo's of completed CWC sent to NID				
Submission of device MAC addresses				
Device registration				

Project Responsibilities	ICL NID Team	Main Contractor	M&E Contractor	Data Contractor
Horizontal cabling				
Data cabling				
Data Containment -sized for 40% expansion				
EZ paths along route (where applicable)				
Hole for EZ path along route (where applicable)				
Data modules				
Data faceplates				
Data backboxes (minimum depth applies)				
Floor box data plates (where applicable)				
Data backboxes for H/L (Wi-Fi / CCTV)				
Data backboxes for BEMS				
Data backboxes for Access Control / FA panel				
Data termination				
Data blank inserts (where applicable)				
Data outlet labelling Inc wrap around labels				
Data cabling testing Inc warranty application				
Patch cords				
Patching at Outlets				
Backbone cabling				
CW1308 cabling to lifts / metering				
108a frame (where applicable)				
Voice cabling to MDF (where applicable)				
Supply/termination and testing of voice components				
Voice labelling				
Voice testing				
Ordering of BT lines (where applicable)				
Jumpering of BT lines onto College network				
Fibre cabling				
Fibre trays & components				
Fibre termination & labelling				
Fibre patch cords				
Fibre testing inc warranty application				
Fibre patching to switches				
ODF & fibre cassettes (where applicable)				
ODF trunk cables (where applicable) & patch cords (where applicable)				
ODF patching (where applicable)				
Internal containment for backbone cabling				
External containment for backbone cabling (Ducting)				
Duct sealing for internal penetrations				
Duct sealing for internal penetrations after cabling install				

